

# **XENSIV™ DPS310/368**

# **Pressure Sensor 2Go Kit**

User Guide

11/2/2022





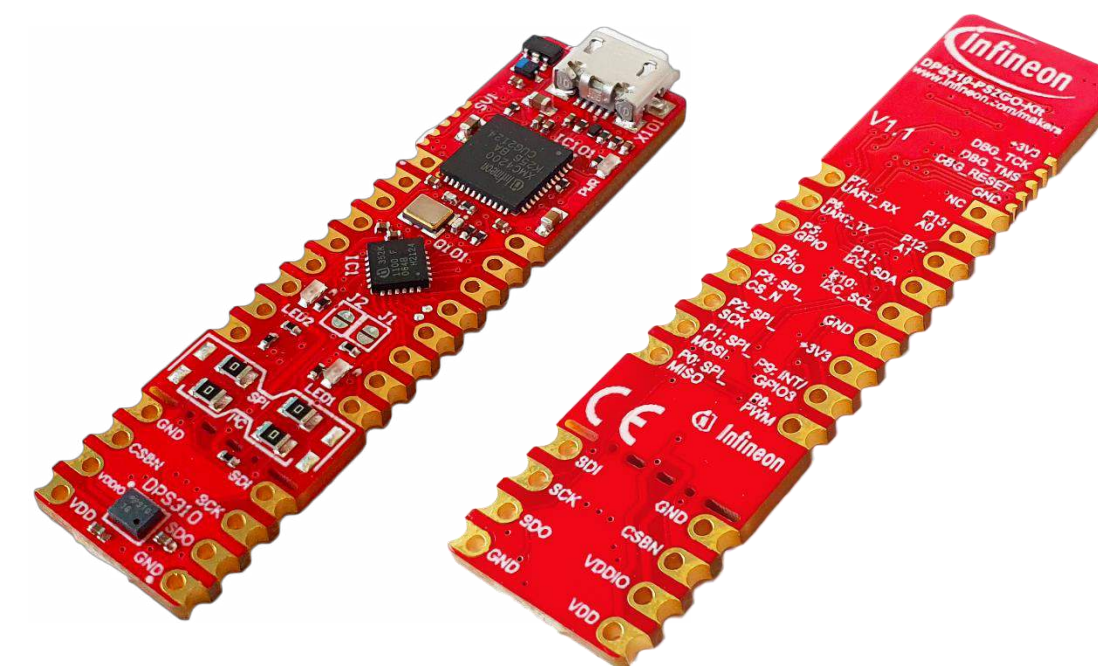
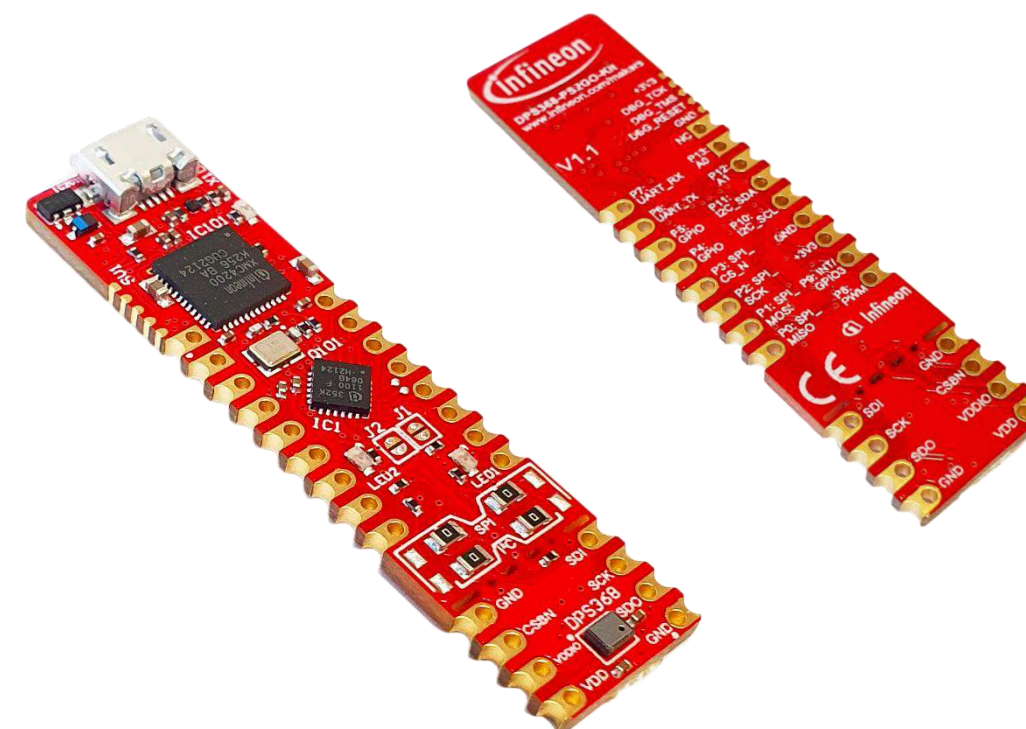

# Introducing the DPS310/368 Kit2Go

## Summary of features

- i Compatible with Arduino IDE - Fast and easy access to measurement results
- i On-board DPS310/368:
  - Pressure operation range: 300 –1200 hPa.
  - Temperature operation range: -40 – 85 °C.
  - Pressure sensor precision:  $\pm 0.002$  hPa (or  $\pm 0.02$  m)
  - Temperature accuracy:  $\pm 0.5^\circ\text{C}$
  - DPS368 is IPx8 certified: Temporary immersion of 50m for 1 hour
- i XMC1100 (ARM® Cortex™-M0 based)
- i On-board J-Link Lite Debugger
  - Realized with XMC4200 Microcontroller
- i Power over Micro-USB (Plug&Play)
- i Sensor measurements available through I<sup>2</sup>C or SPI interface
- i ESD and reverse current protection
- i 2x User LEDs
- i Pin Header 1x9 and 1x8 (Shield2Go form factor)
- i Pin out on top (head) is directly connected to the pins of the DPS
- i Breakable head for individual sensor usage
  - After breaking, head and MCU/Debugger Peripherals can still be used independently
- i Standard delivery interface mode is I<sup>2</sup>C



# Introduction

-  The DPS310/368 is a miniaturized digital barometric air pressure sensor with ultra-high precision ( $\pm 2$  cm) and a low current consumption, capable of measuring both pressure and temperature
-  Due to the robust package of the DPS368, it can withstand harsh environments e.g. 50 m under water for one hour (IPx8)
-  Both pressure sensor elements are based on a capacitive sensing principle which guarantees high precision during temperature changes. The small package makes the DPS310/368 ideal for mobile applications and wearable devices
-  The internal signal processor converts the output from the pressure and temperature sensor elements to 24 bit results. Each unit is individually calibrated and the calibration coefficients calculated during this process are stored in the calibration registers. The coefficients are used in the application to convert the measurement results to high accuracy pressure and temperature values
-  The result FIFO can store up to 32 measurement results, allowing for a reduced host processor polling rate. Temperature and Pressure measurement results are readable through the serial I2C or SPI interface making it easily and quickly accessible by e.g. Arduino IDE or Platform.IO with Arduino Extension



Link to [Datasheet](#) and [Product Page](#)



Link to [Datasheet](#) and [Product Page](#)

# Board Information

- ❗ Connect the Micro-USB to your PC to power up the Kit2Go. *PWR* LED turns **green** indicating proper power supply
- ❗ Micro-USB delivers 5 V to power-up the Kit2Go. When breaking the board apply no more than 3.3 V to the DPS
- ❗ Pin out on the bottom (HEAD) is directly connected to the pins of the DPS310/368
- ❗ If the head is broken off:
  - Two capacitors are connected to the DPS310/368
  - MCU and Debugger can still be used
  - ⚠ To use the I<sup>2</sup>C mode, place a pull-up resistors on the lines between *VDDIO-SDI* and *VDDIO-SCK* (max. 10kΩ each)
  - Debugger can also be accessed via SV1
- ❗ Software compatible with Arduino and library fully integrated into the Arduino IDE with help of [Infineon's GitHub page](#).
- ❗ Standard delivery of the board (in terms of interface mode) is I<sup>2</sup>C with Address 0x77 when the 0 Ohm resistors are soldered as shown on the right picture
- ❗ Sales Name: *KIT\_DPS310\_2GO* and *KIT\_DPS368\_2GO*

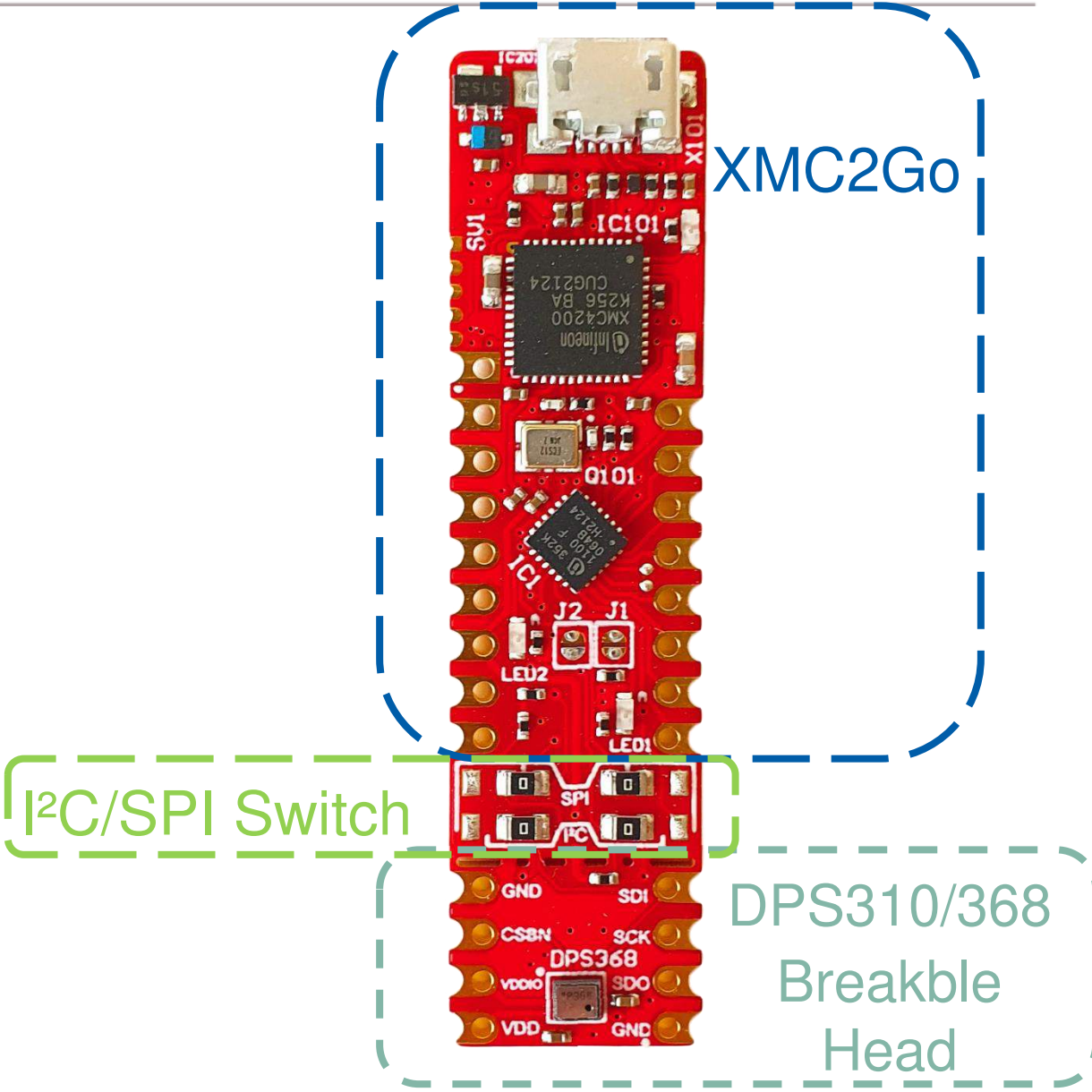

**MAKE SURE THAT NO VOLTAGE APPLIED TO ANY OF THE PINS EXCEEDS THE ABSOLUTE MAXIMUM RATING OF 4 V**

# Kit2Go PCB Details

## The DPS Pressure Kit2Go



### Legend

<span style="background-color: yellow; border: 1px solid black; display: inline-block; width: 10px; height: 10px;"></span>	Information
<span style="background-color: blue; border: 1px solid black; display: inline-block; width: 10px; height: 10px;"></span>	Labelling of Pins in Datasheet
<span style="background-color: lightgreen; border: 1px solid black; display: inline-block; width: 10px; height: 10px;"></span>	Pin Number in Arduino IDE
<span style="background-color: black; border: 1px solid black; display: inline-block; width: 10px; height: 10px;"></span>	Physical Pin Number
	Warning
	Additional Information
<span style="background-color: yellow; border: 1px solid black; padding: 2px;">NC</span>	Not Connected

- Max voltage on any pin is 4 V.
- If board is powered through 3.3V pin, it is not recommended to power through USB and vice versa
- LED1 & LED2 are user LEDs and correspond to Arduino Pins 14&15 respectively.
- I<sup>2</sup>C pull-up resistors are already integrated.

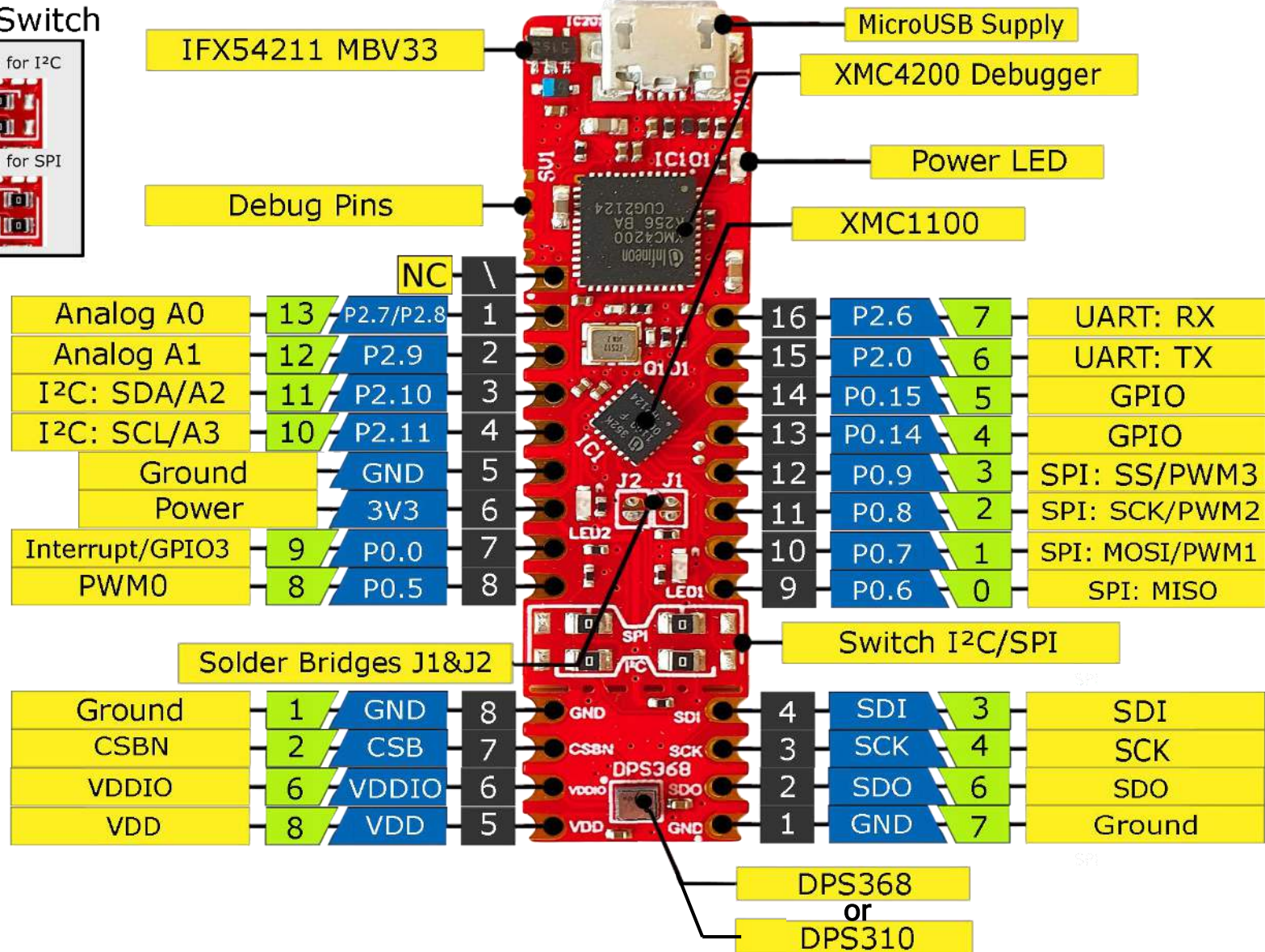
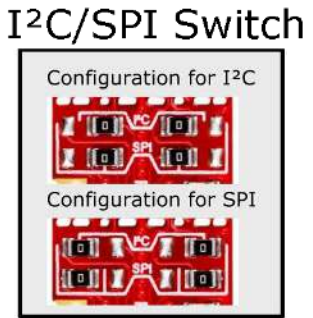

# Board Schematic (XMC2Go related)

## Power Supply

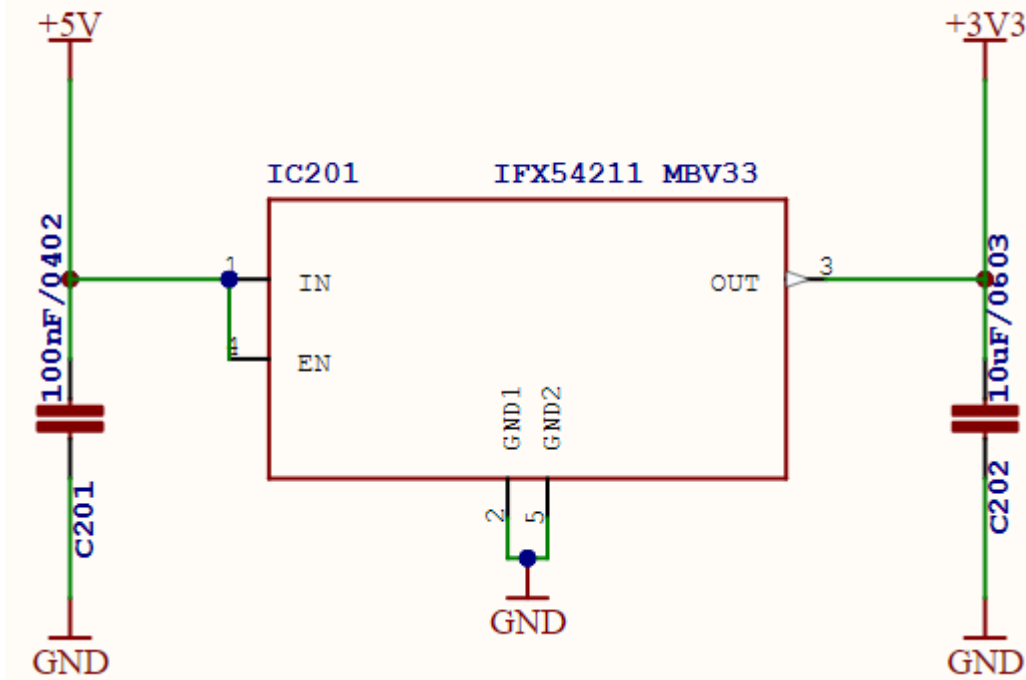

## XMC Debugger

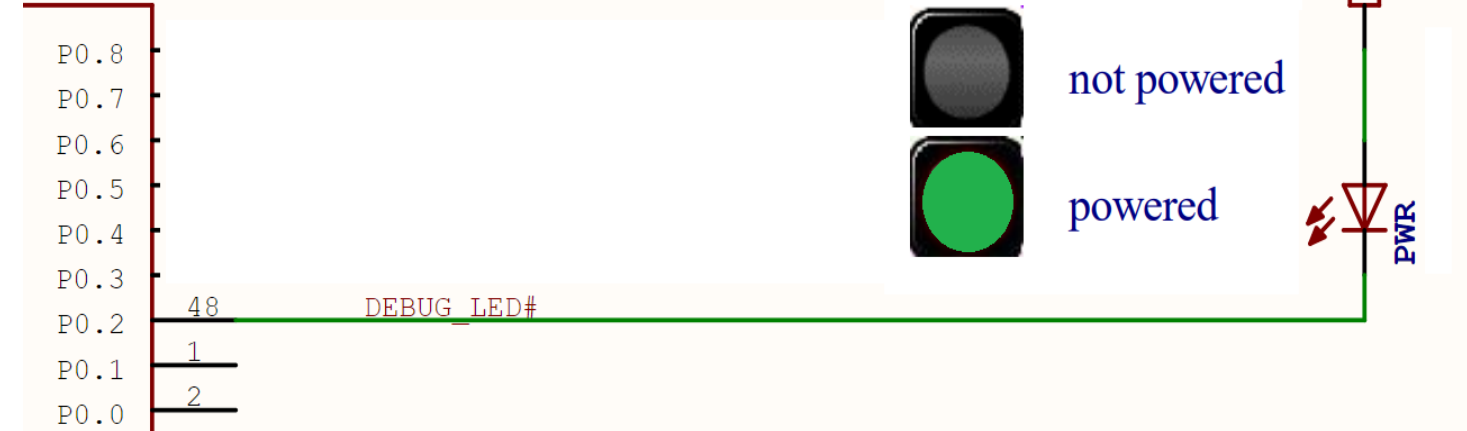

- The Infineon DC-DC converter transforms the 5 V of the Micro-USB to 3.3 V for the MCU, Debugger and Peripherals circuits
- The green PWR LED indicates a proper power supply for the Kit2GO
- The 2 green User-LEDs (LED1 -> P1.0 and LED2 ->P1.1) might be configured separately by pulling-up the according GPIOs

## LEDs

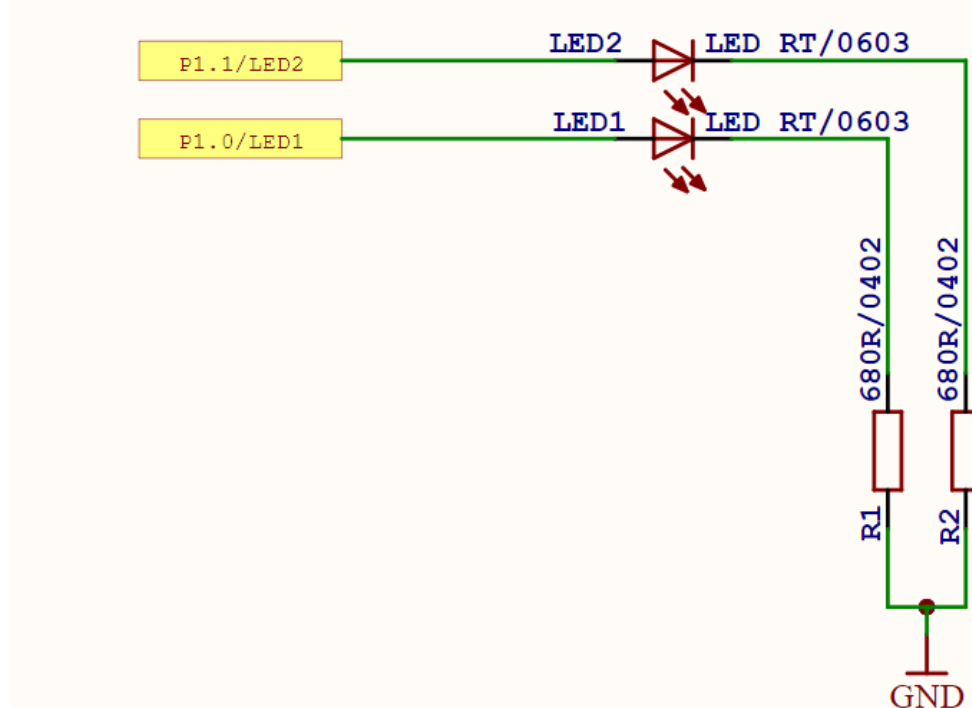

# Board Schematic (DPS310/368 related)

## SPI/I<sup>2</sup>C Selection Circuit

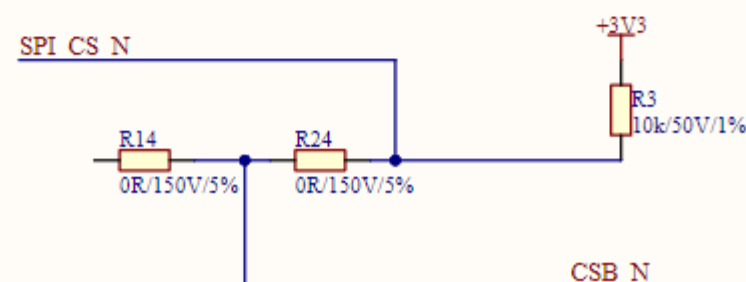
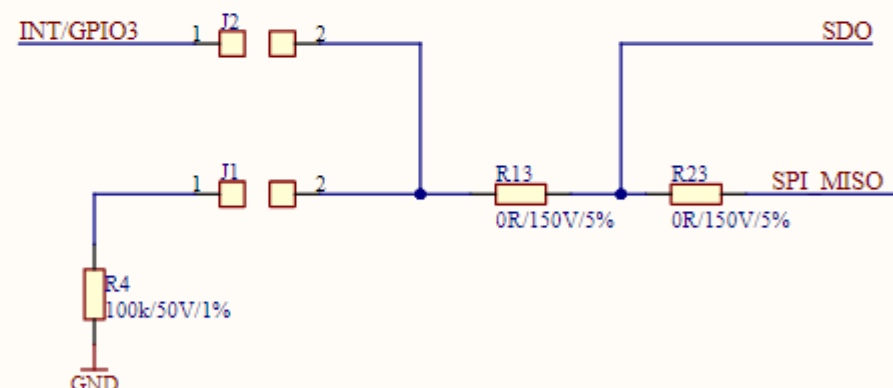
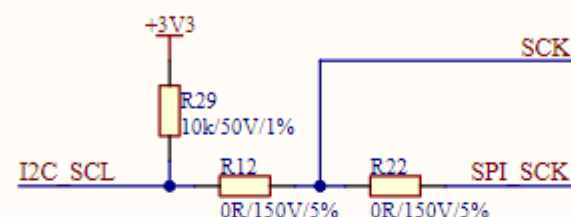
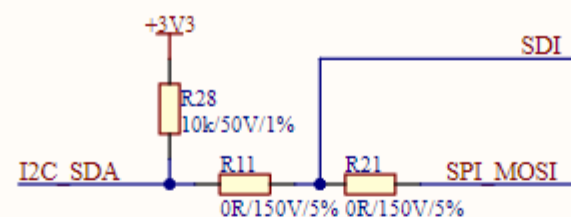

Circuit, if the head  
is broken off

## DPS310/368

### Power Supply Decoupling

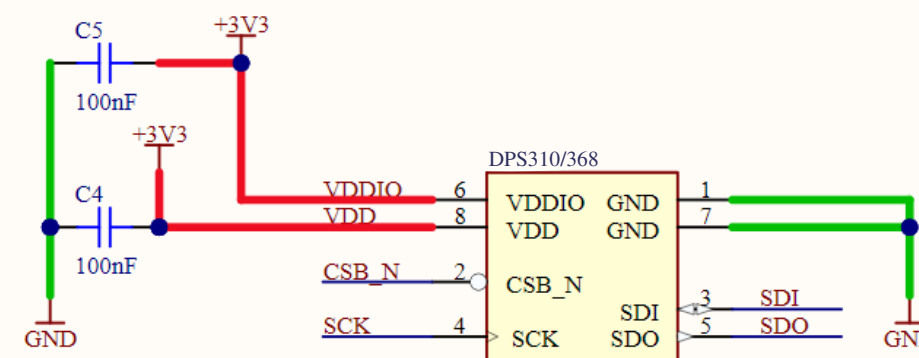

### Shield2Go Head

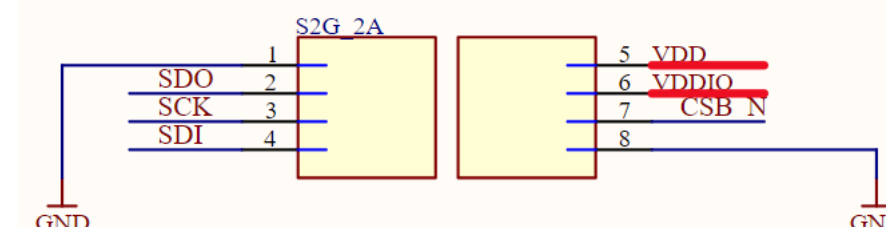

- Default Mode (0Ω-Resistors *R11, R12, R13* and *R14* soldered): I<sup>2</sup>C with optional interrupt
- Secondary Mode (0Ω-Resistors *R21, R22, R23* and *R24* soldered): SPI 4-Wire
- J1 Jumper: If soldered, enables the pull-down resistor on the interrupt pin and changes the I<sup>2</sup>C address from 0x77 to 0x76
- J2 Jumper: If soldered, connects the INT/GPIO3 pin

# Arduino: The Arduino IDE

## Arduino IDE



Arduino is a hardware-software prototyping environment IDE developed by arduino.cc:



- Installation Details for Windows: Click [here](#)
- Installation Details for Linux: Click [here](#)
- Installation Details for Mac OS: Click [here](#)
- Installation Details for Portable IDE: Click [here](#)

## Arduino Quick Start

- What is Arduino? Click [here](#)
- Extended information about the Arduino environment. Click [here](#)
- How to import libraries? Click [here](#)
- How to install additional boards? Click [here](#)
- Problems related to Arduino? Click [here](#) for troubleshooting



# SEGGER J-Link

-  In order to use and program the Infineon XMC microcontroller in the Arduino IDE, SEGGER J-Link must be installed on your PC
-  Please follow this link to [SEGGER J-Link](#) and install the J-Link Software and Documentation Pack for your operating system
-  The XMC-for-Arduino installs the XMC Flasher tool used to flash the compiled firmware (.hex) into the XMC device, which requires **Java(TM) SE Runtime Environment** to be installed in the host system. Click [here](#) to download.

 Open the Arduino IDE

 Navigate to *File=>Preferences*

 Paste the following URL into the 'Additional Boards Manager URLs' input field:  
`https://github.com/Infineon/Assets/releases/download/current/package_infineon_index.json`

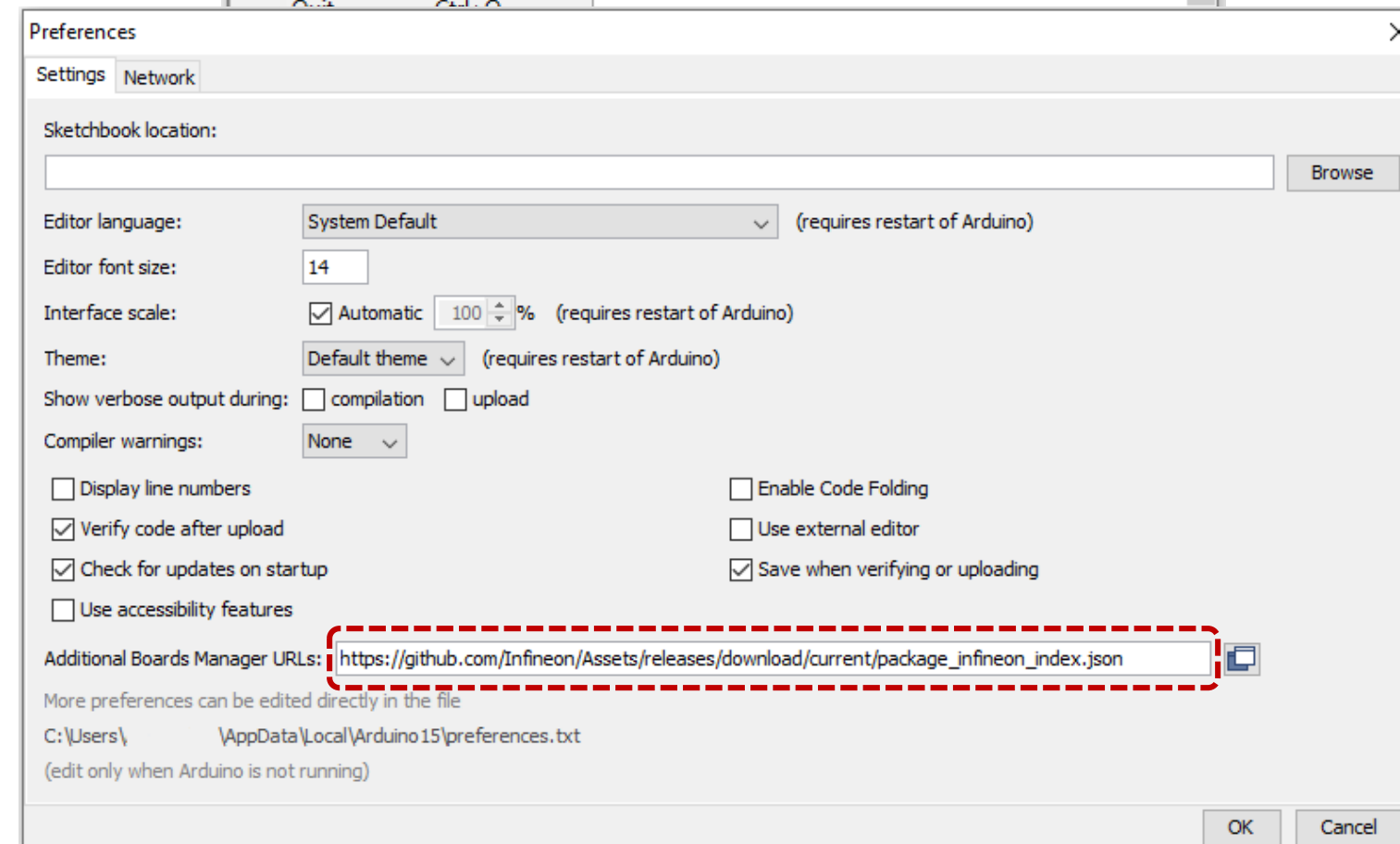
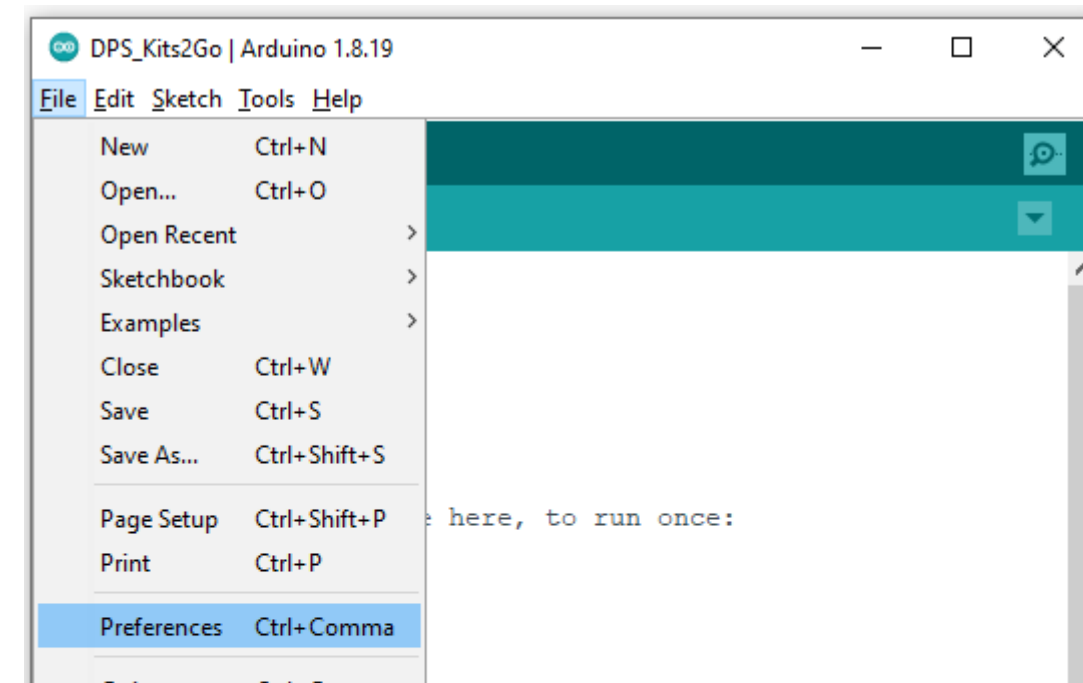

# Setup Arduino IDE - Board

- ⑧ Open the Arduino IDE
- ⑧ Navigate to *Tools=>Board=>Boards Manager...*
- ⑧ Type in “xmc” and install Infineon’s XMC Microcontroller Boards
- ⑧ After installation navigate to *Tools=>Board=>XMC Family* and select *XMC1100 XMC2Go*

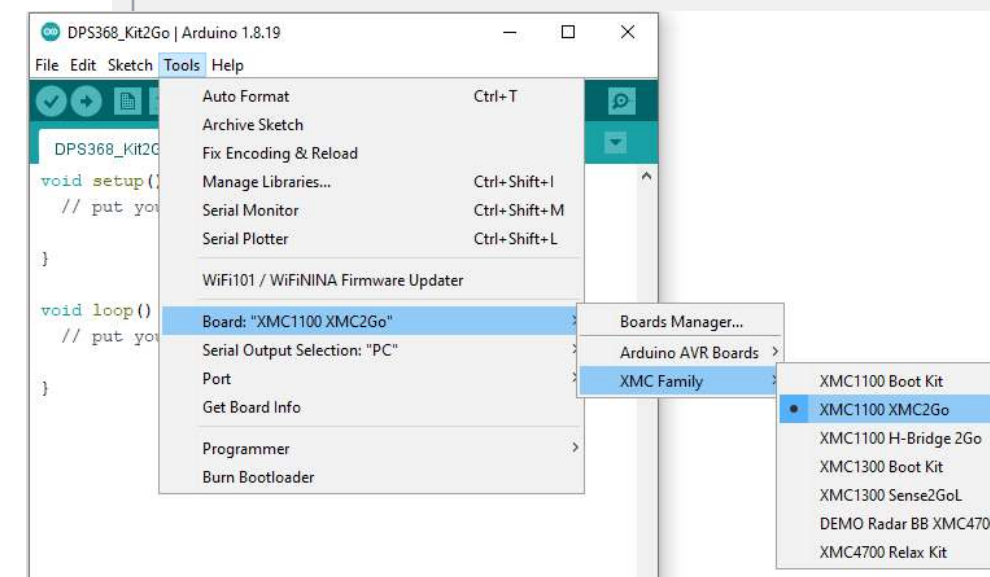
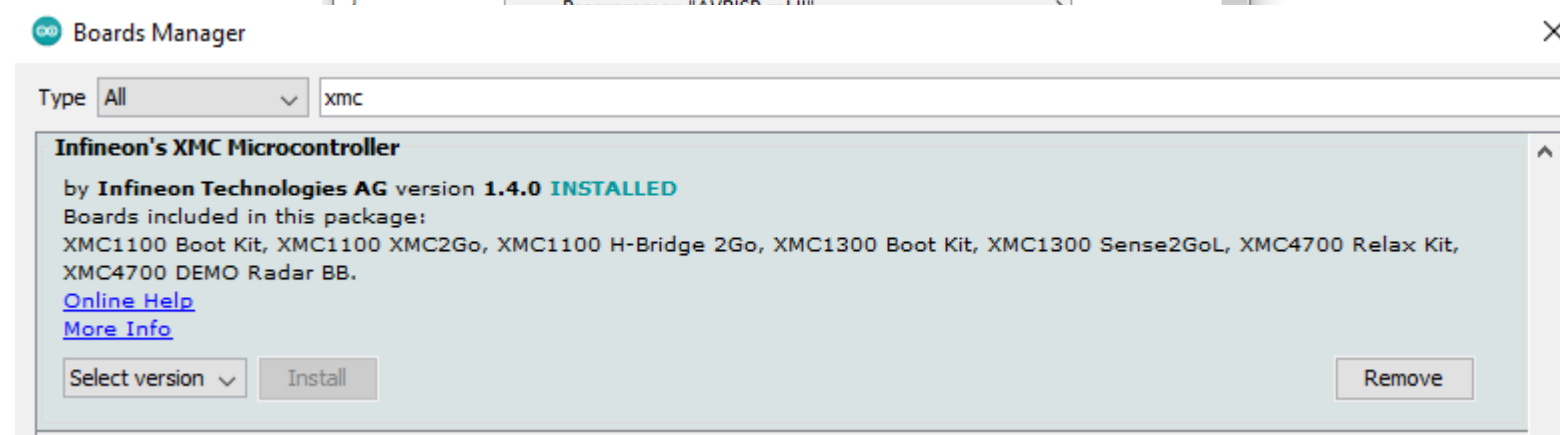
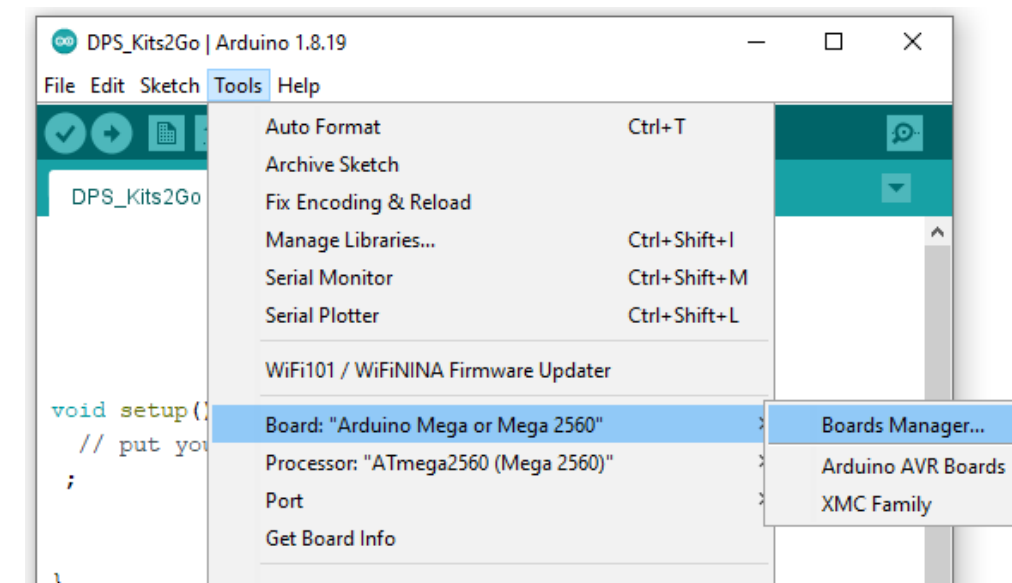

# Setup Arduino IDE - Library

## For the DPS310:

- ☞ Navigate to *Sketch=>Include Library=>Manage Libraries...*
- ☞ Type “*dps*” in the search bar
- ☞ Install “*DigitalPressureSensor*” by Infineon Technologies

## Alternative:

- ☞ Visit our [GitHub Repository](#) and download the library as a .zip file
- ☞ Navigate to *Sketch=>Include Library=>Add .ZIP Library...* and add the recently installed library

## For the DPS368:

- ☞ Visit our [GitHub Repository](#) and download the library as a .zip file
- ☞ Navigate to *Sketch=>Include Library=>Add .ZIP Library...* and add the recently installed library

## Note

- ☞ Regularly check your installed libraries for updates
- ☞ In case of problems, please visit the corresponding GitHub Repository and open an issue to get further help

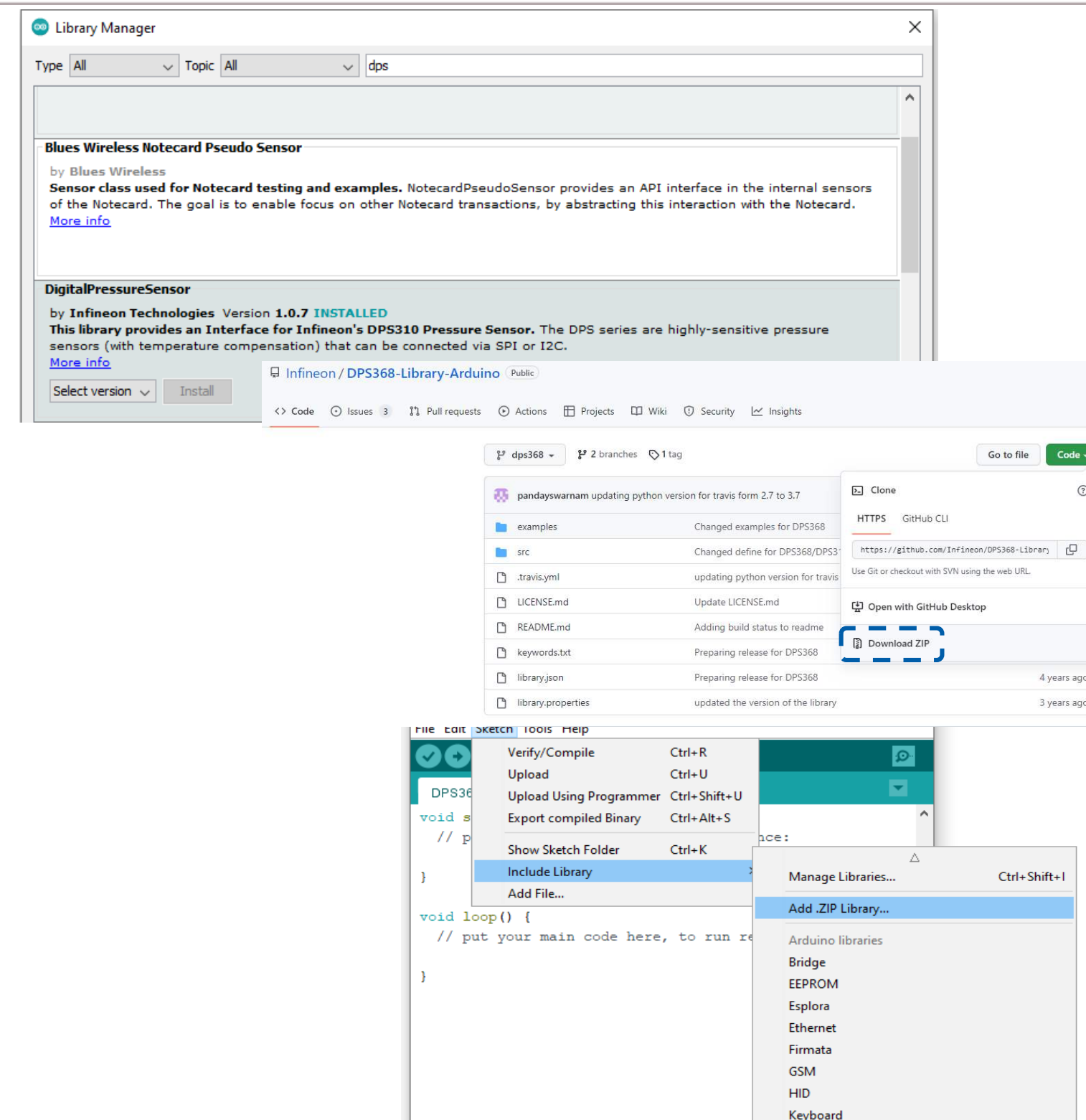

# Example with DPS368 Kit2Go

- Connect the DPS368 Kit2Go to your Computer via Micro-USB
- After having installed the DPS368 library and the XMC Family boards, navigate to *File=>Examples*
- Pick the example you like (depending on your I<sup>2</sup>C/SPI configuration) and click on the upload Button (*make sure Board is XMC1100 XMC2Go*)
- Select the related COM port from *Tools=>Port* and open the serial monitor with the set baud rate (see sketch/code with `Serial.begin(<baud rate>);`)
- Follow the same steps for the DPS310 Kit2Go

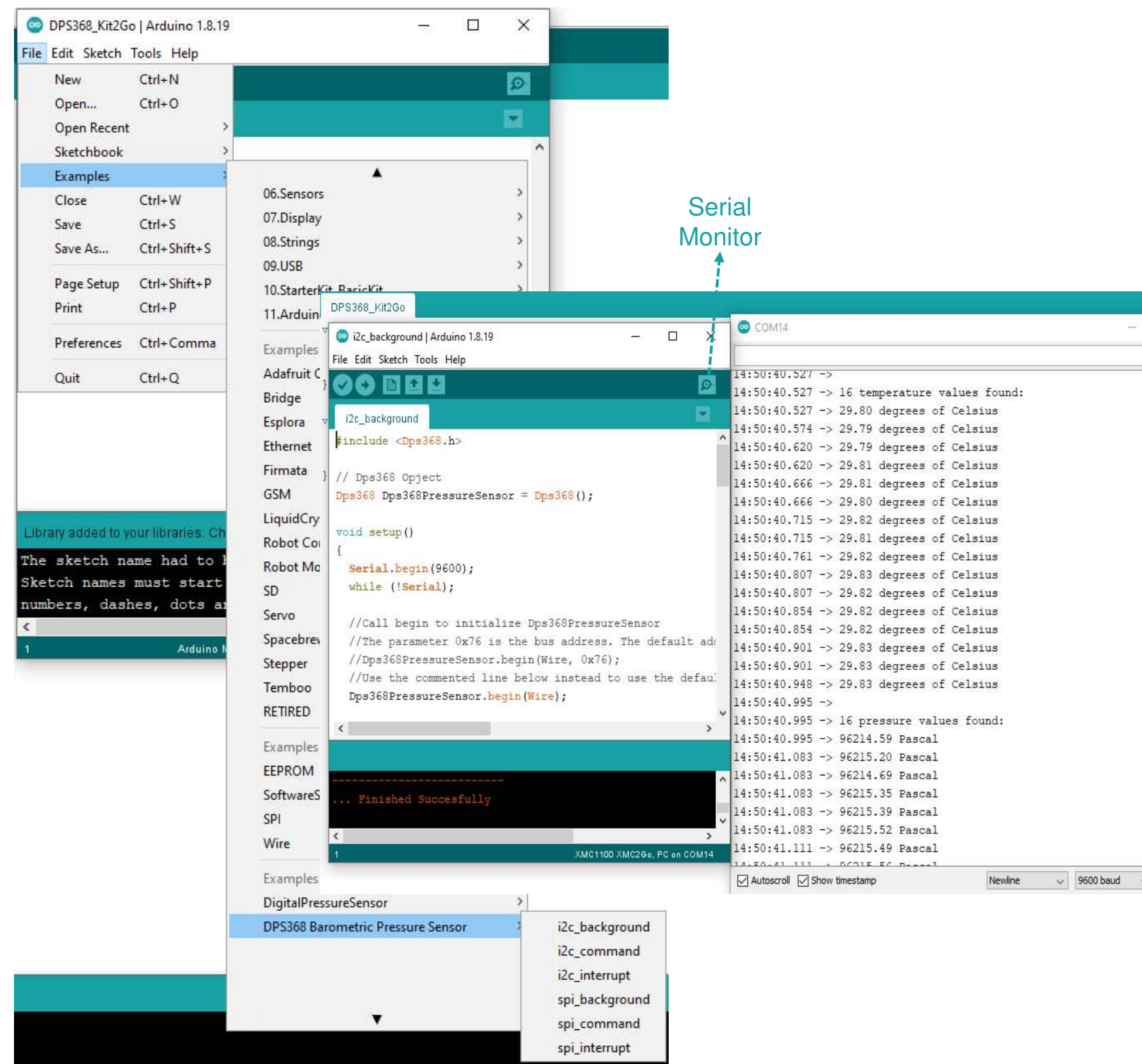

# ! Important Warning !

- ⚠ Again, the DPS310/368 has a maximum rating of 4 V
- ⚠ Third party boards with 5 V logic, e.g. the Arduino Uno, **cannot be connected to the DPS310/368 Kit2Go board directly**, even if the power is connected to the 3.3 V pin as the interface lines, e.g. SDA/SCL, will still be driven by 5 V
- ⚠ Please use appropriate level shifting for these boards

**NOT POSSIBLE**

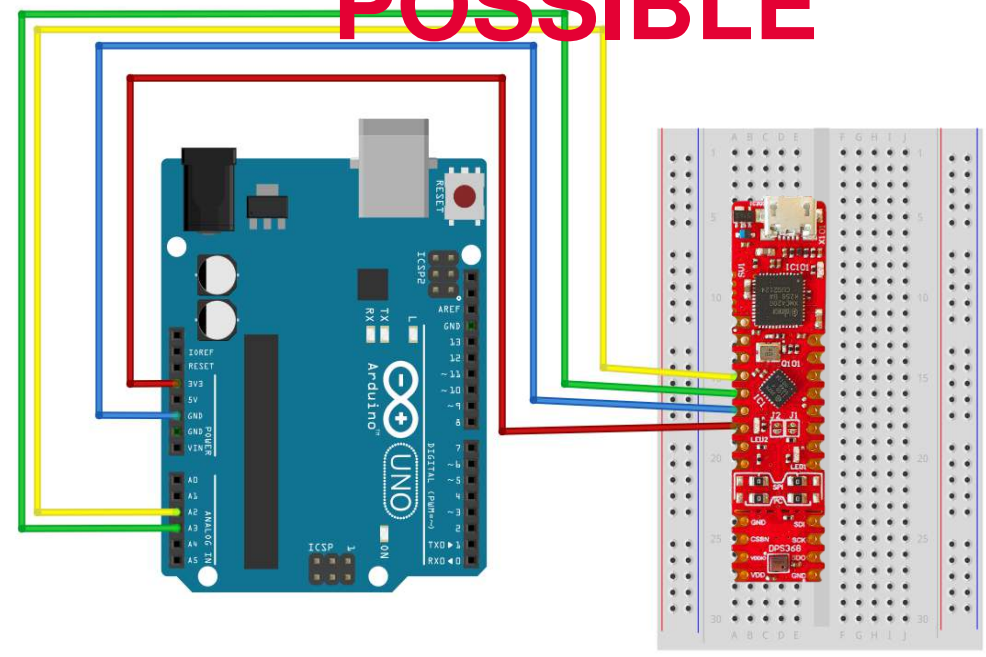

**POSSIBLE**

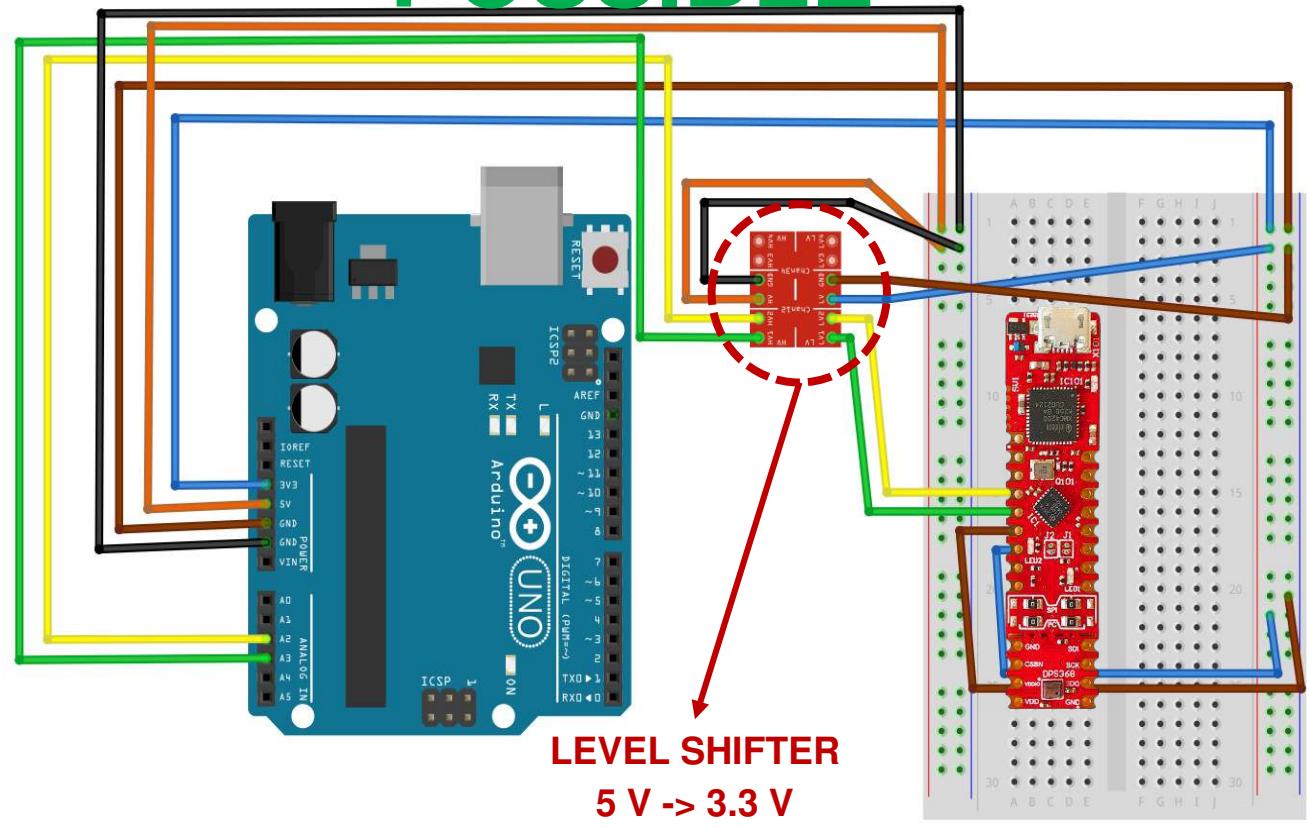

Connection Ports

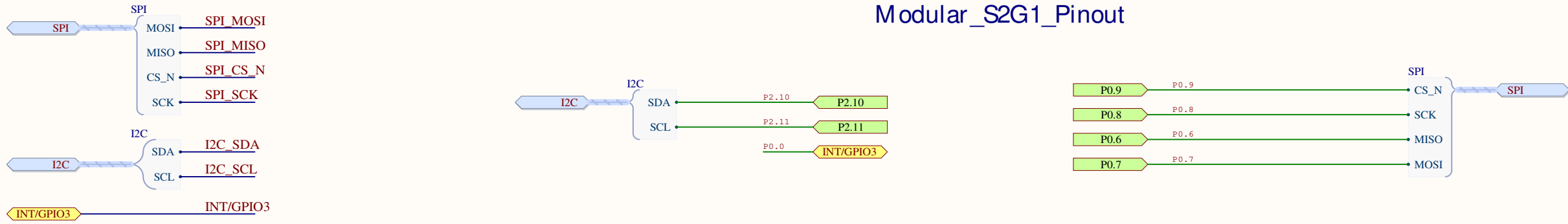

SPI/I<sup>2</sup>C Selection Circuit

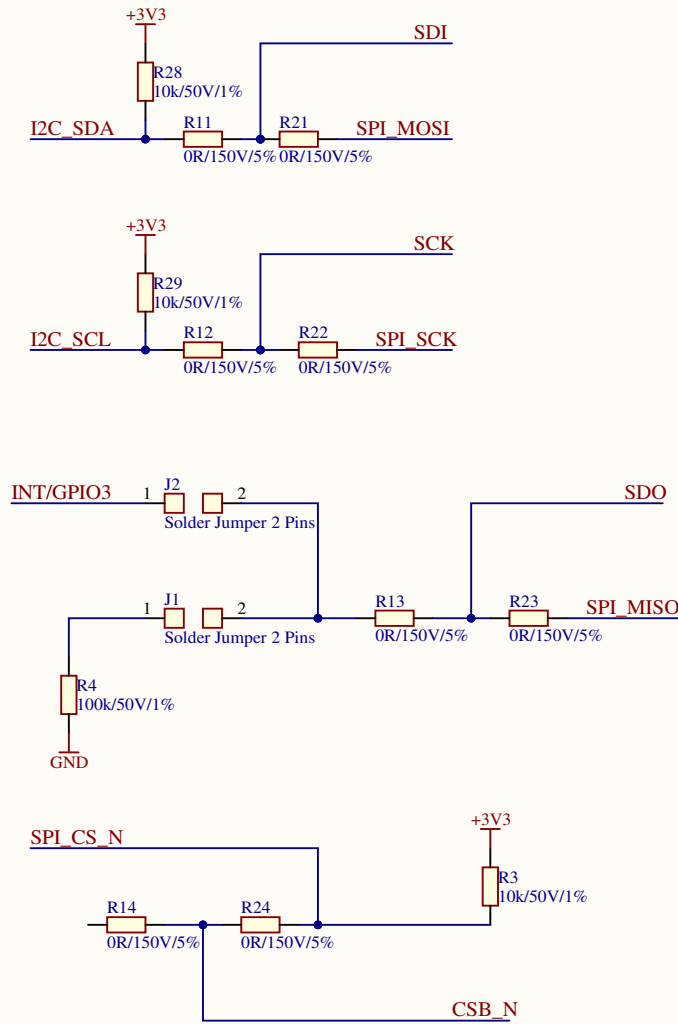

DPS310

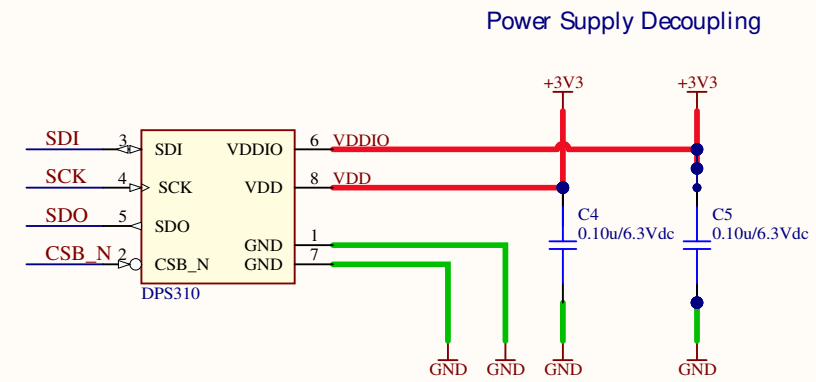

Shield2Go Head

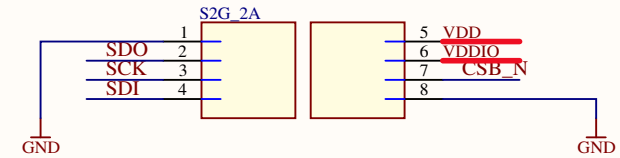

Default Mode (ZERO Ohm resistors 11,12,13,14 are soldered) - I<sup>2</sup>C with Interrupt (Optional)  
 Secondary Mode (ZERO Ohm resistors 21,22,23,24 are soldered) - SPI 4 Wire

J1 Jumper - Can be soldered to enable the pull-down resistor on the interrupt pin (this will also change the address of the sensor from 0x77 to 0x76)

J2 Jumper - Can be soldered to connect the INT/GPIO3 pin



Title DPS310-PS2GO-Kit			
Variant [No Variations]		Approved <Appr.>	
Size: A3	Document Name DPS310-PS2GO-Kit	Rel.	Rev. V1.0
Author: Date: 27.01.2022 Time: 10:50:05		SVN Revision: 6a271a99e872f0dfdc6241b5de	
		Sheet of 2	

Connection Ports

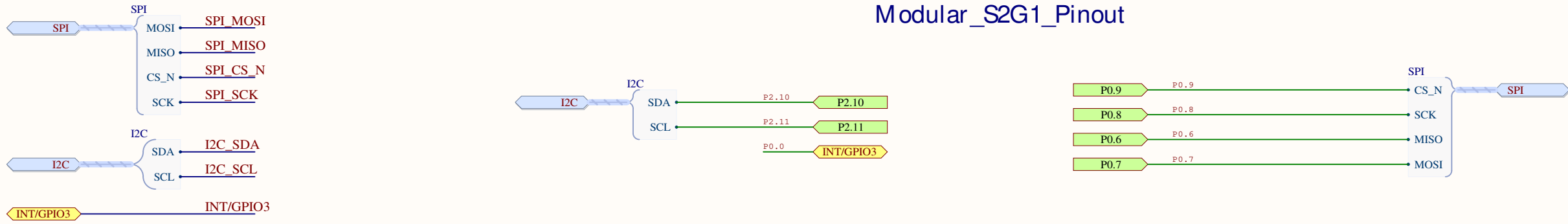

SPI/I<sup>2</sup>C Selection Circuit

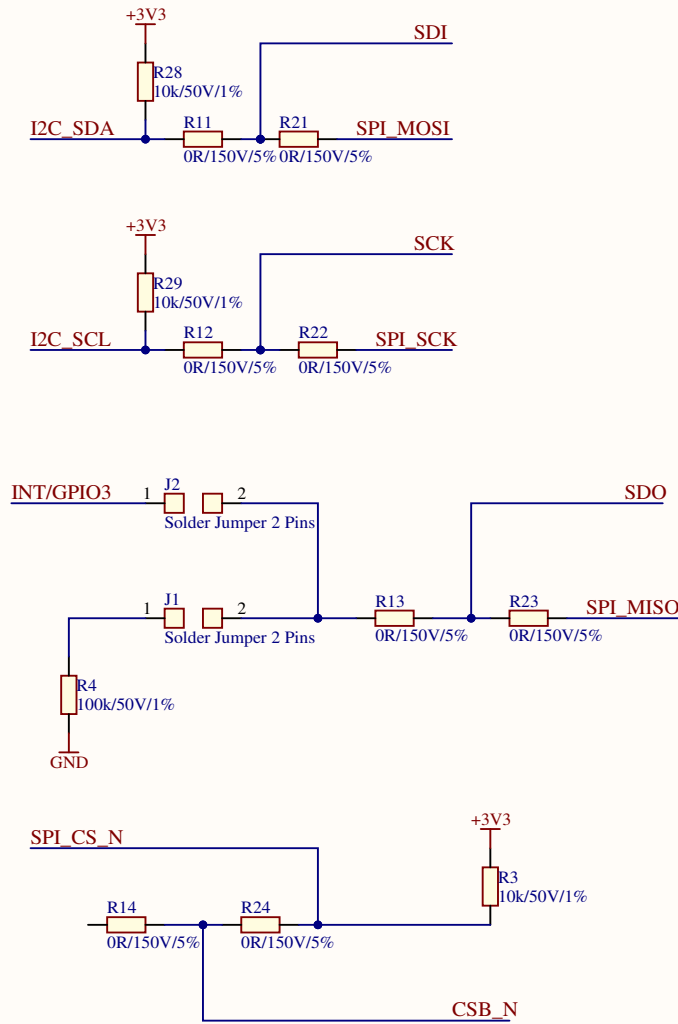

DPS368

Power Supply Decoupling

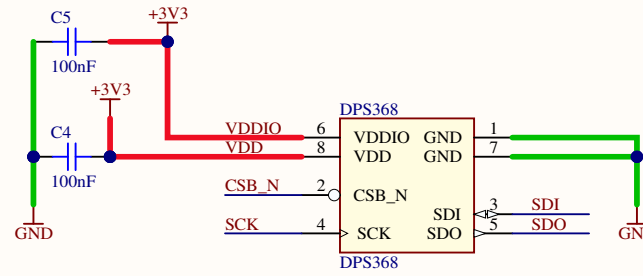

Shield2Go Head

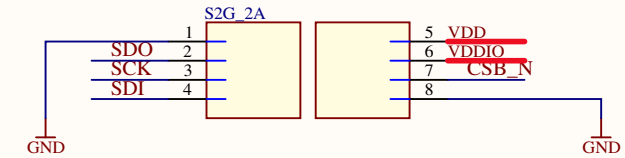

Default Mode (ZERO Ohm resistors 11,12,13,14 are soldered) - I<sup>2</sup>C with Interrupt (Optional)

Secondary Mode (ZERO Ohm resistors 21,22,23,24 are soldered) - SPI 4 Wire

J1 Jumper - Can be soldered to enable the pull-down resistor on the interrupt pin (this will also change the address of the sensor from 0x77 to 0x76)

J2 Jumper - Can be soldered to connect the INT/GPIO3 pin



Title DPS368-PS2GO-Kit			
Variant [No Variations]		Approved <Appr.>	
Size: A3	Document Name DPS368-PS2GO-Kit	Rel.	Rev. V1.0
Author: Date: 27.01.2022 Time: 10:42:22		SVN Revision: 6a271a99e872f0dfdc6241b5de	
		Sheet of 2	

# XMC 2Go Kit

## XMC1100 in VQFN24

On-board Debugger including a UART to USB Bridge

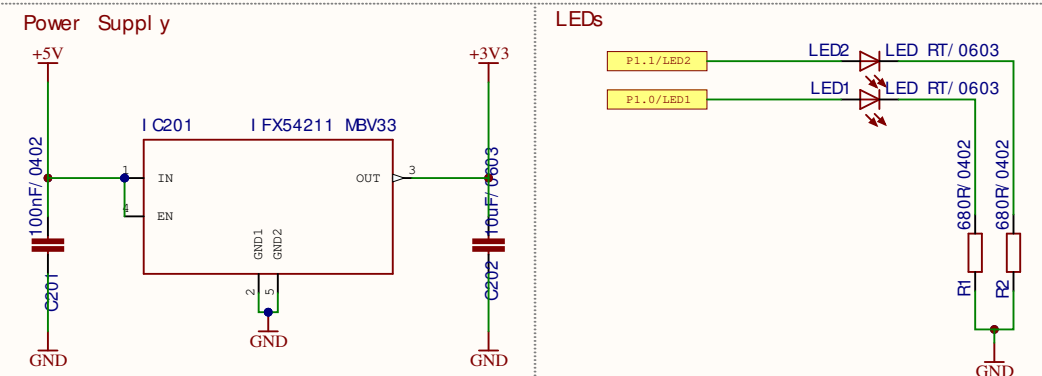
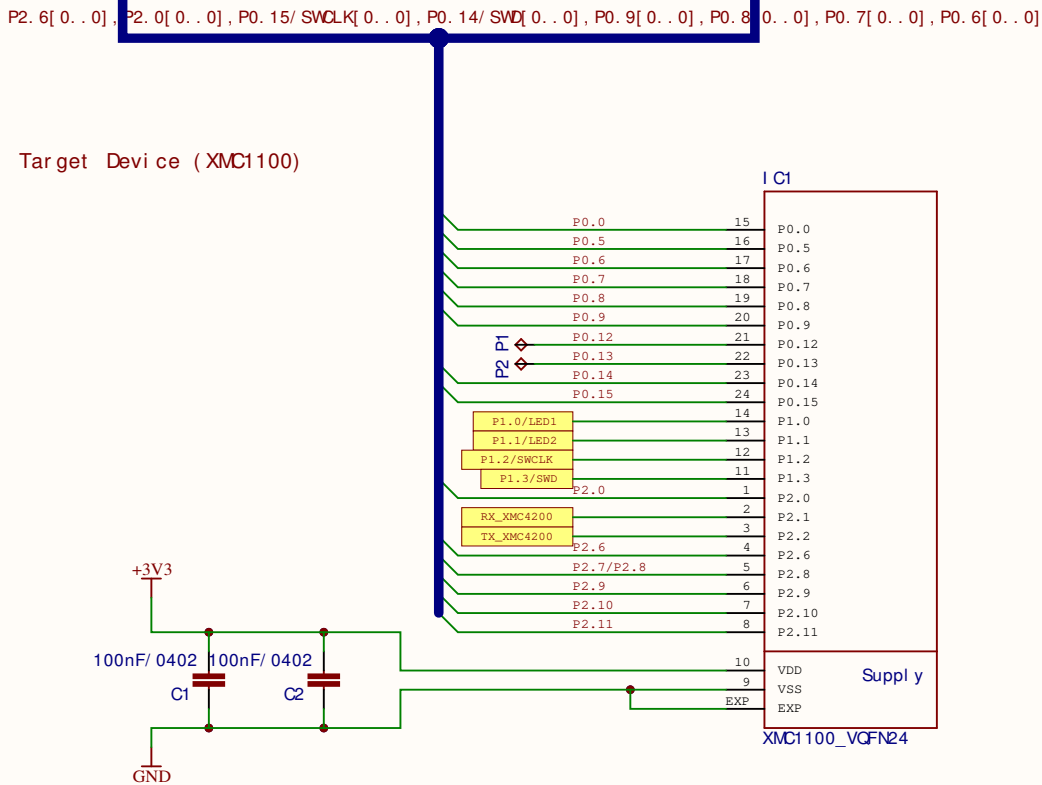
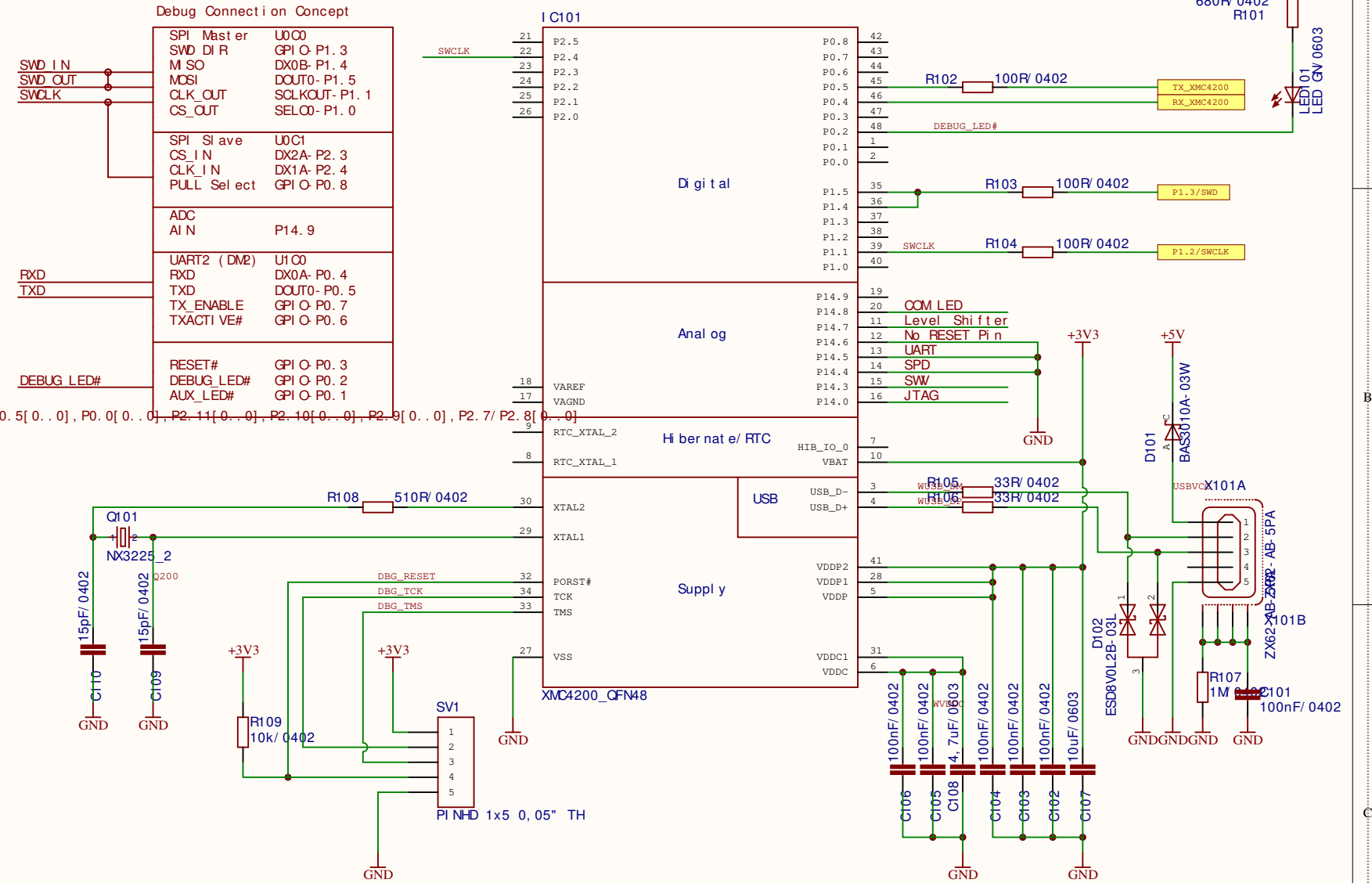
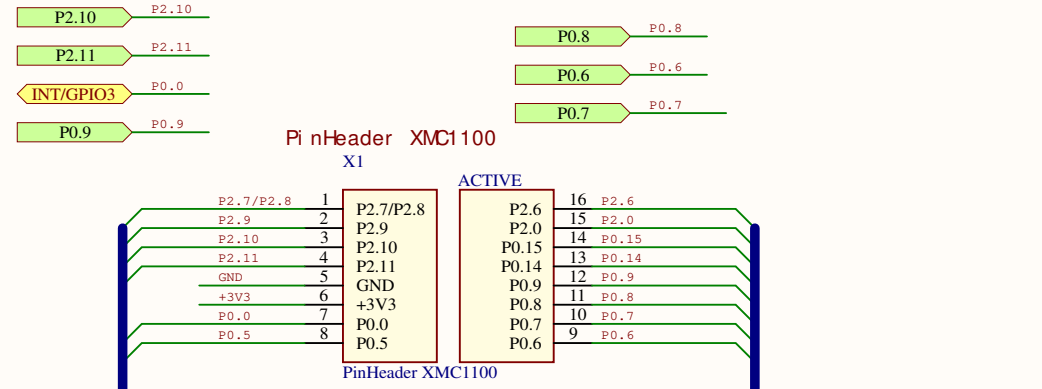

**Legal Disclaimer**

The information given in this document shall in no event be regarded as a guarantee of conditions or characteristics. With respect to any examples or hints given herein, any typical values stated herein and/or any information regarding the application of the device, Infineon Technologies hereby disclaims any and all warranties and liabilities of any kind, including without limitation, warranties of non-infringement of intellectual property rights of any third party.

For further information and software examples please visit [www.infineon.com/xmc-dev](http://www.infineon.com/xmc-dev)

Configure wiggler-P0.5 as USI\_C.Tx but only active while X-spy function is selected  
Configure wiggler-P0.4 as USI\_C.Rx but only active while X-spy function is selected

Power Supply : 200-299  
Debugging Device : 100-199  
Target Device : 1-99

Title DPS368-PS2GO-Kit			
Variant [No Variations]		Approved <Appr.>	
Size: A3	Document Name DPS368-PS2GO-Kit	Rel. V1.0	Rev. V1.0
Author:			
Date: 27.01.2022 Time: 10:42:22		SVN Revision: 6a271a99e872f0dfdc6241b5d6	
		Sheet of 2	





Part of your life. Part of tomorrow.