

ACPL-8x4

Multi-Channel Full-Pitch Phototransistor Optocoupler

Description

The Broadcom[®] ACPL-824 is an AC-input dual channel full-pitch phototransistor optocoupler which contains four light emitting diode optically coupled to two separate phototransistors. It is packaged in a 8-pin DIP package.

Likewise, the ACPL-844 is an AC-input quad channel full-pitch phototransistor optocoupler which contains eight light emitting diode optically coupled to four separate phototransistors. It is packaged in a 16-pin DIP package

For both types, it is also available in wide-lead spacing option and lead bend SMD option with input-output isolation voltage at 5000 Vrms. Response time, t_r , is typically 4 μ s and CTR is 20% to 300%.

Features

- Current transfer ratio (CTR: min. 20% at $I_F = \pm 1$ mA, $V_{CE} = 5$ V)
- High input-output isolation voltage ($V_{ISO} = 5000V_{RMS}$)
- Response time (t_r : typical 4 μ s at $V_{CE} = 2$ V, $I_C = 2$ mA, $R_L = 100\Omega$)
- Compact dual-in-line package
- Safety and regulatory approvals:
 - CSA
 - UL 1577
 - IEC/EN/DIN EN 60747-5-5
- Options available:
 - Leads with 0.4-inch (10.16-mm) spacing (W00)
 - Lead bend for surface mounting (300)
 - Tape and reel for SMD (500) - ACPL-824 only
 - IEC/EN/DIN EN 60747-5-5 approved (060)
 - Lead-Free (000E)

Applications

- I/O interface for programmable controllers, computers
- Sequence controllers
- System appliances, measuring instruments
- Signal transmission between circuits of different potentials and impedances

ACPL-824 Pin Layout

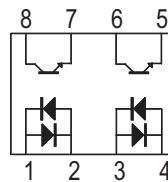

Pin 1, 3	Anode or Cathode
Pin 2, 4	Cathode or Anode
Pin 5, 7	Emitter
Pin 6, 8	Collector

ACPL-844 Pin Layout

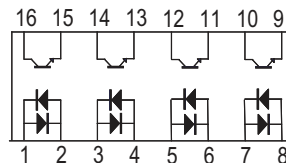

Pin 1, 3, 5, 7	Anode or Cathode
Pin 2, 4, 6, 8	Cathode or Anode
Pin 9, 11, 13, 15	Emitter
Pin 10, 12, 14, 16	Collector

Ordering Information

ACPL-8x4 is UL Recognized with 5000Vrms for 1 minutes per UL 1577 and is approved under CSA Component Acceptance Notice #5, File CA 88324.

Part Number	RoHS Compliant Option	Package	Number of Channels	Surface Mount	Gull Wing	Tape and Reel	IEC/EN/DIN EN 60747-5-5	Quantity
	Rank '0' 20% < CTR < 300%							
ACPL-824	-000E	300 mil DIP-8	Dual					50 pcs per tube
	-300E	300 mil DIP-8		X	X			50 pcs per tube
	-500E	300 mil DIP-8		X	X	X		1000 pcs per reel
	-060E	300 mil DIP-8					X	50 pcs per tube
	-360E	300 mil DIP-8		X	X		X	50 pcs per tube
	-560E	300 mil DIP-8		X	X	X	X	1000 pcs per reel
	-W00E	400 mil DIP-8						50 pcs per tube
	-W60E	400 mil DIP-8					X	50 pcs per tube
ACPL-844	-000E	300 mil DIP-16	Quad					25 pcs per tube
	-300E	300 mil DIP-16		X	X			25 pcs per tube
	-060E	300 mil DIP-16					X	25 pcs per tube
	-360E	300 mil DIP-16		X	X		X	25 pcs per tube
	-W00E	400 mil DIP-16						25 pcs per tube
	-W60E	400 mil DIP-16					X	25 pcs per tube

To order, choose a part number from the part number column and combine with the desired option from the option column to form an order entry.

Example 1:

ACPL-824-360E to order product of 300 mil DIP-8 Dual Channel AC Gull Wing Surface-Mount package in Tube packaging with 20% < CTR < 300%, IEC/EN/DIN EN 60747-5-5 Safety Approval and RoHS compliant.

Example 2:

ACPL-844-W00E to order product of 400 mil DIP-16 Quad Channel AC package in Tube packaging with 20% < CTR < 300% and RoHS compliant.

Option datasheets are available. Contact your Broadcom sales representative or authorized distributor for information.

Package Outline Drawings

ACPL-824 Package Outline

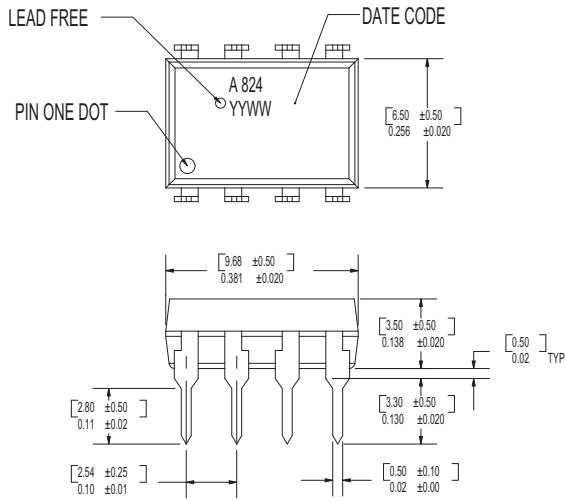

Dimensions in [millimeters] and inches

ACPL-824 Package Outline - Option 060

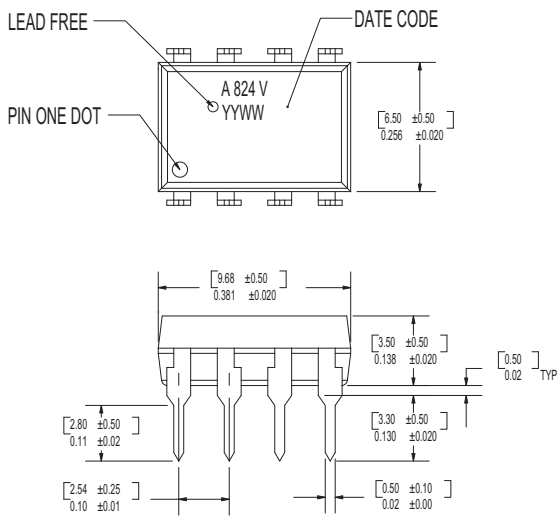

Dimensions in [millimeters] and inches

ACPL-824 Package Outline - Option W00

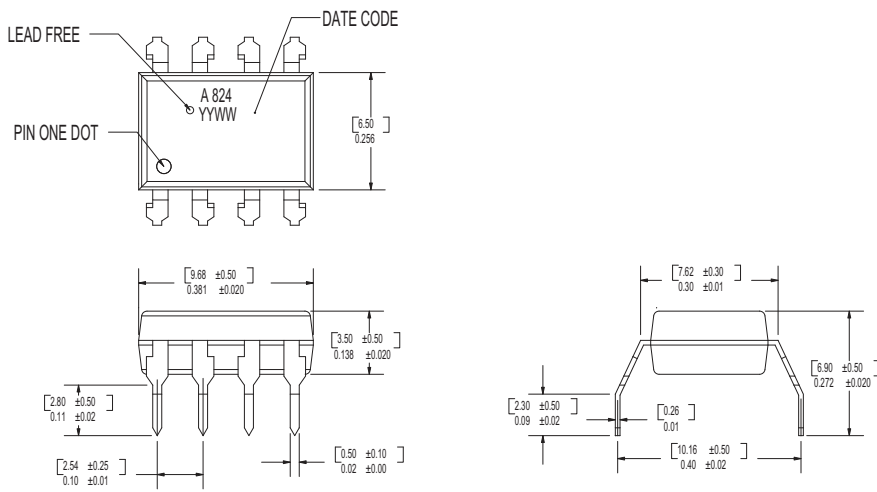

Dimensions in [millimeters] and inches

ACPL-824 Package Outline - Option 300

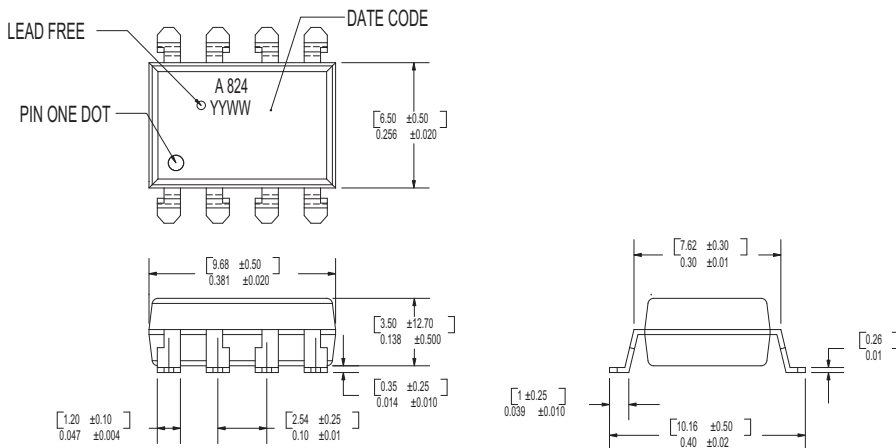

Dimensions in [millimeters] and inches

ACPL-844 Package Outline

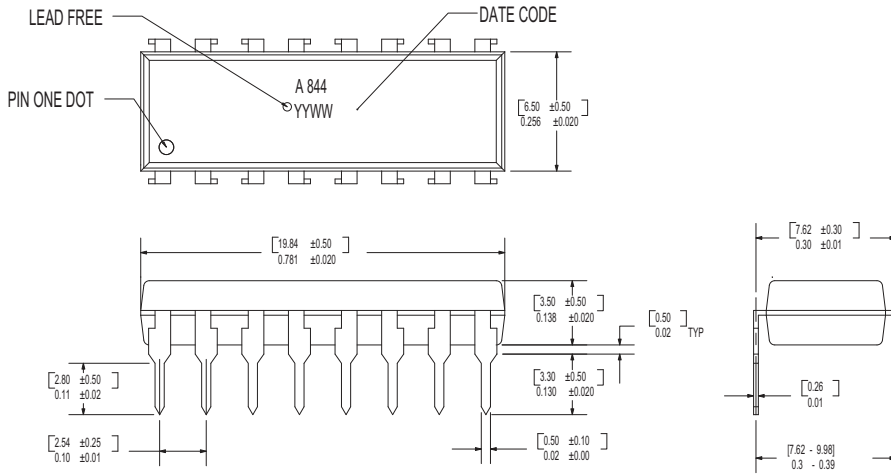

Dimensions in [millimeters] and inches

ACPL-844 Package Outline - Option 060

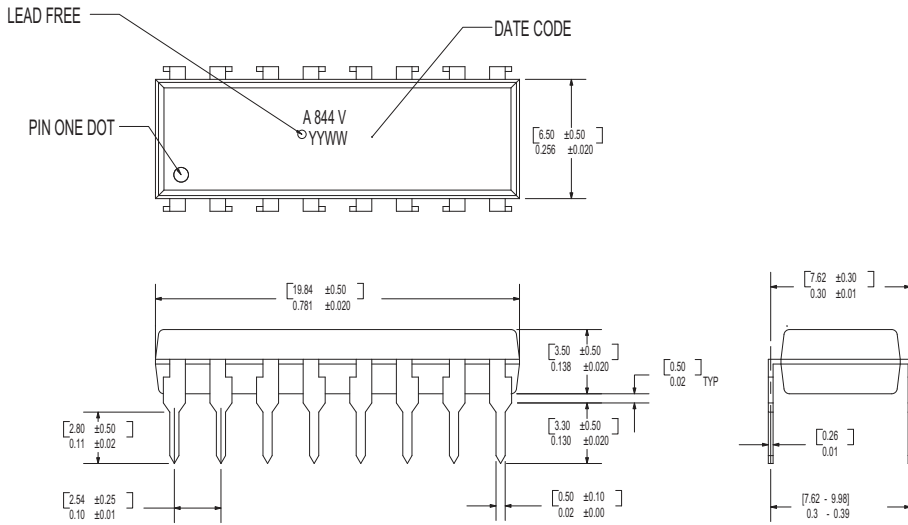

Dimensions in [millimeters] and inches

ACPL-844 Package Outline - Option W00

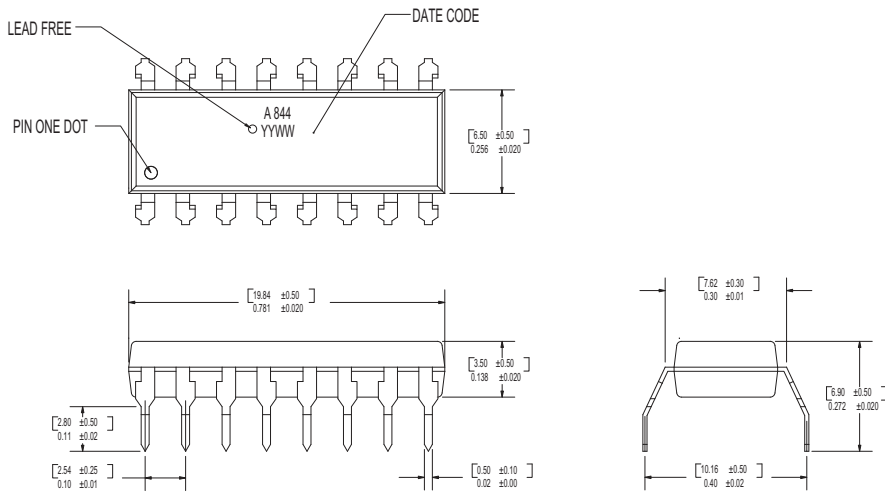

Dimensions in [millimeters] and inches

ACPL-844 Package Outline - Option 300

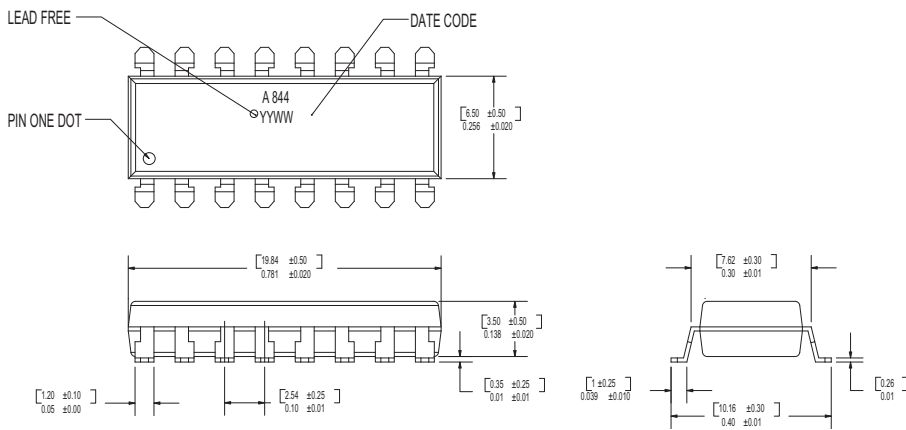

Dimensions in [millimeters] and inches

Solder Reflow Temperature Profile

1. One-time soldering reflow is recommended within the condition of temperature and time profile shown at right.
2. When using another soldering method such as infrared ray lamp, the temperature may rise partially in the mold of the device. Keep the temperature on the package of the device within the condition of (1) above.

NOTE: Use non-halide flux.

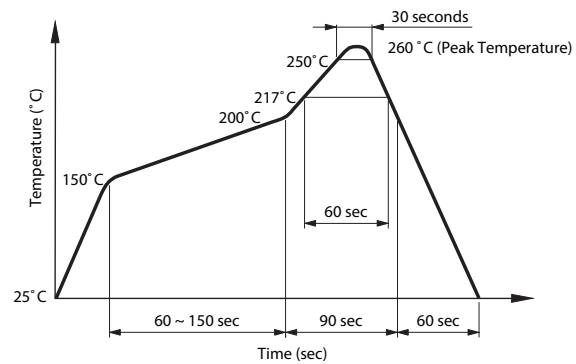

Absolute Maximum Ratings

Parameter	Symbol	Min.	Max.	Units	Note
Storage Temperature	T_S	-55	125	°C	
Operating Temperature	T_A	-30	100	°C	
Average Forward Current	$I_{F(AVG)}$	—	±50	mA	
Input Power Dissipation	P_I	—	70	mW	
Collector Current	I_C	—	50	mA	
Collector-Emitter Voltage	V_{CEO}	—	70	V	
Emitter-Collector Voltage	V_{ECO}	—	6	V	
Isolation Voltage (AC for 1 minute, RH 40%~60%)	V_{ISO}	—	5000	V_{RMS}	
Collector Power Dissipation	P_C	—	150	mW	
Total Power Dissipation	P_{TOT}	—	200	mW	
Lead Solder Temperature	260°C for 10s, 1.6 mm below seating plane				

Electrical Specifications

Over recommended operating conditions unless otherwise specified.

Parameter	Symbol	Min.	Typ.	Max.	Units	Test Conditions	Fig.	Note
Forward Voltage	V _F	—	1.2	1.4	V	I _F = ±20 mA		
Terminal Capacitance	C _t	—	50	250	pF	V = 0V, f = 1 kHz		
Collector Dark Current	I _{CEO}	—	—	100	nA	V _{CE} = 20V, I _F = 0 mA,		
Collector-Emitter Breakdown Voltage	B _{VCEO}	70	—	—	V	I _C = 0.1 mA, I _F = 0 mA		
Emitter-Collector Breakdown Voltage	B _{VECO}	6	—	—	V	I _E = 10 μA, I _F = 0 mA		
Collector Current	I _C	0.2	—	3	mA	I _F = ±1 mA, V _{CE} = 5V		CTR = (I _C /I _F) * 100%
Current Transfer Ratio	CTR	20	—	300	%			
Collector-Emitter Saturation Voltage	V _{CE(sat)}	—	0.1	0.2	V	I _F = ±20 mA, I _C = 1 mA		
Isolation Resistance	R _{ISO}	5x10 ¹⁰	1x10 ¹¹	—	Ω	DC500V, RH 40~60%		
Floating Capacitance	C _F	—	0.6	1	pF	V = 0V, f = 1 MHz		
Cut-off Frequency (-3 dB)	F _C	15	80	—	kHZ	V _{CE} = 5V, I _C = 2 mA, R _L = 100Ω	13	
Response Time (Rise)	t _r	—	4	18	μs	V _{CE} = 2V, I _C = 2 mA, R _L = 100Ω	12	
Response Time (Fall)	t _f	—	3	18	μs			

Figure 1: Forward Current vs. Ambient Temperature

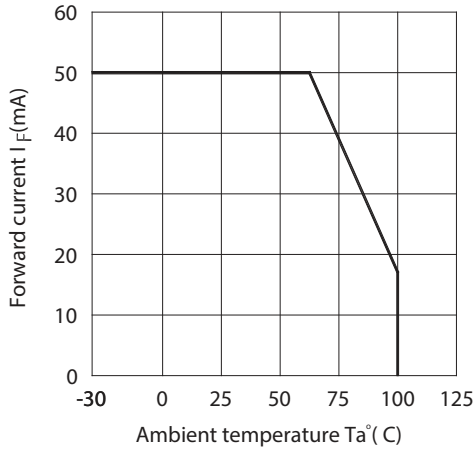

Figure 2: Collector Power Dissipation vs. Ambient Temperature

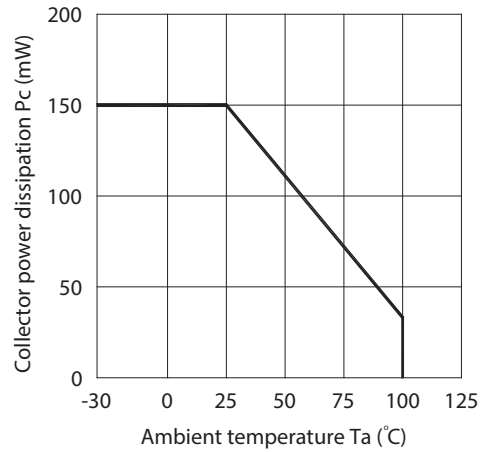

Figure 3: Collector-Emitter Saturation Voltage vs. Forward Current

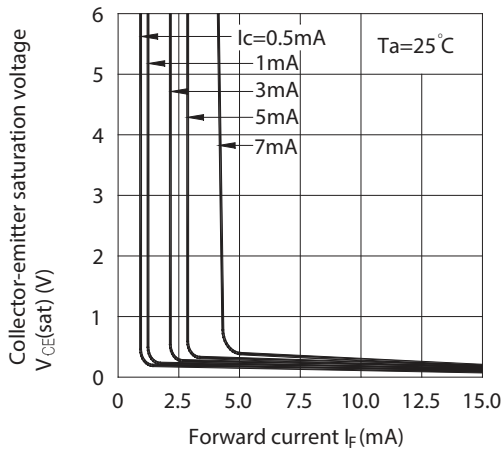

Figure 4: Forward Current vs. Forward Voltage

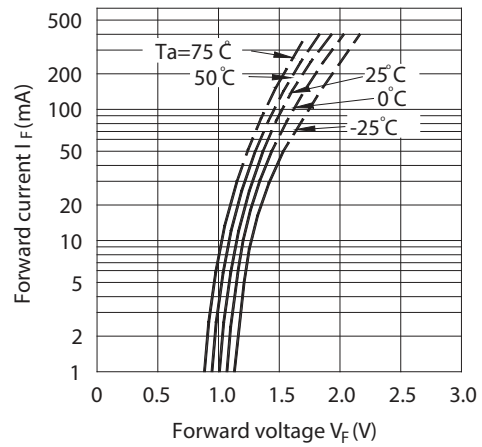

Figure 5: Current Transfer Ratio vs. Forward Current

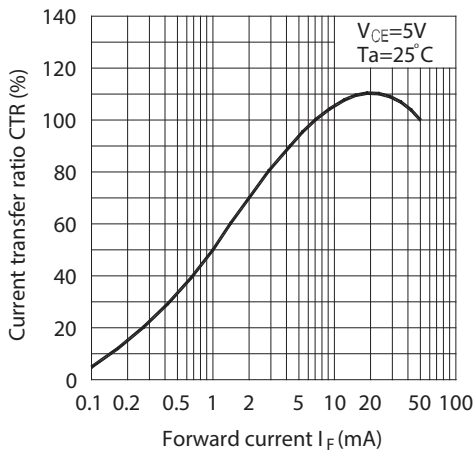

Figure 6: Collector Current vs. Collector-Emitter Voltage

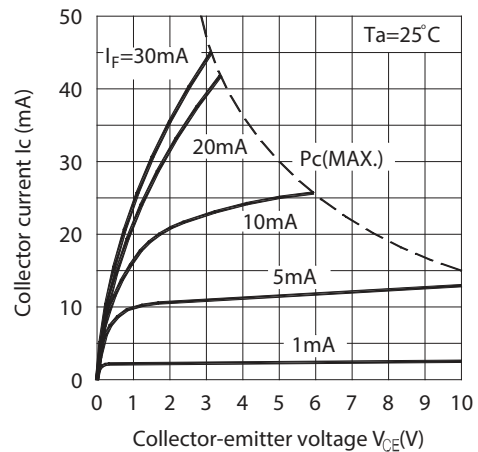

Figure 7: Relative Current Transfer Ratio vs. Ambient Temperature

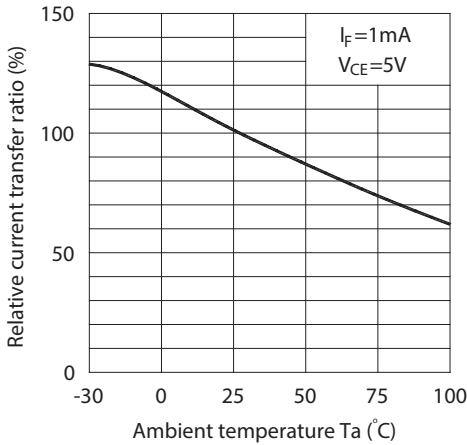

Figure 8: Collector-Emitter Saturation Voltage vs. Ambient Temperature

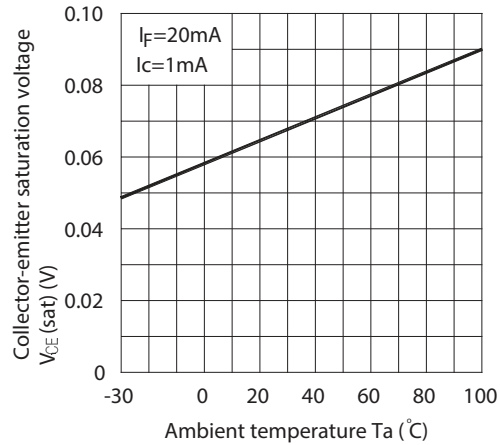

Figure 9: Collector Dark Current vs. Ambient Temperature

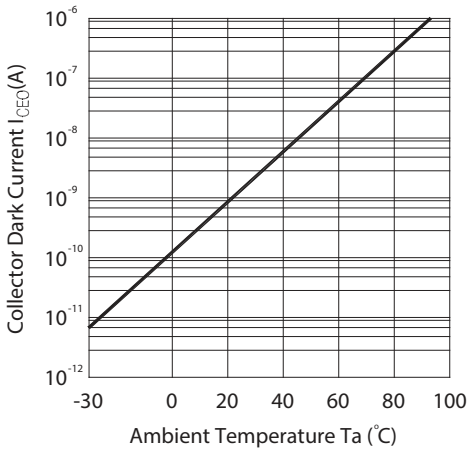

Figure 10: Response Time vs. Load Resistance

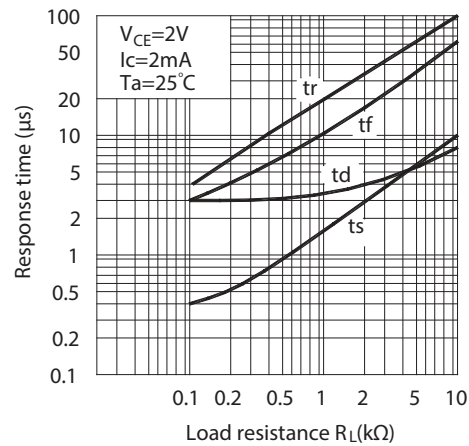

Figure 11: Frequency Response

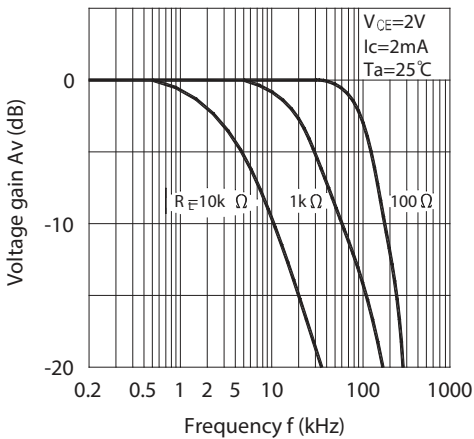

Figure 12: Test Circuit for Response Time

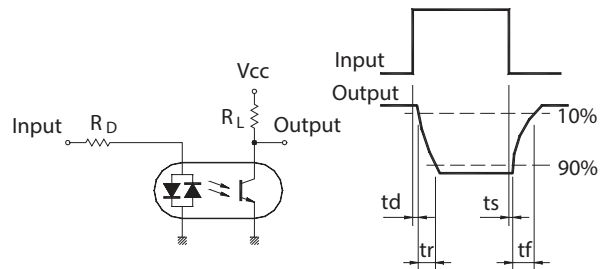
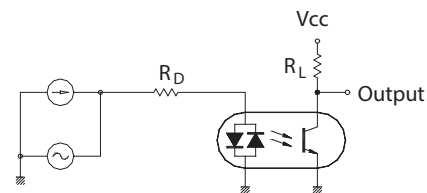

Figure 13: Test Circuit for Frequency Response



Copyright © 2006–2023 Broadcom. All Rights Reserved. The term “Broadcom” refers to Broadcom Inc. and/or its subsidiaries. For more information, go to www.broadcom.com. All trademarks, trade names, service marks, and logos referenced herein belong to their respective companies.

Broadcom reserves the right to make changes without further notice to any products or data herein to improve reliability, function, or design. Information furnished by Broadcom is believed to be accurate and reliable. However, Broadcom does not assume any liability arising out of the application or use of this information, nor the application or use of any product or circuit described herein, neither does it convey any license under its patent rights nor the rights of others.

