

13	12	11	10	9	8	7	6	5	4	3	2	1
MATERIAL NO. LOOSE PC	ENGINEERING NO. LOOSE PC	MATERIAL NO. ON TAPE	ENGINEERING NO. ON TAPE	WIRE SIZE	INSULATOR COLOR	ID MIN REF	MWID	D MAX	L MAX	H NOMINAL	BARE TAB POSITION	
196020004	19602-0004	196020010	19602-0010	22-18 AWG	RED	.058/1.47	.116/2.95	.380/9.65	.880/22.35	.54/13.7	AWAY FROM TAPE	
196020005	19602-0005	196020011	19602-0011	16-14 AWG	BLUE	.079/2.00	.139/3.53	.380/9.65	.880/22.35	.54/13.7	AWAY FROM TAPE	
196020006	19602-0006	196020012	19602-0012	12-10 AWG	YELLOW	.144/3.66	.231/5.87	.380/9.65	1.020/25.91	.57/14.4	TOWARD TAPE	

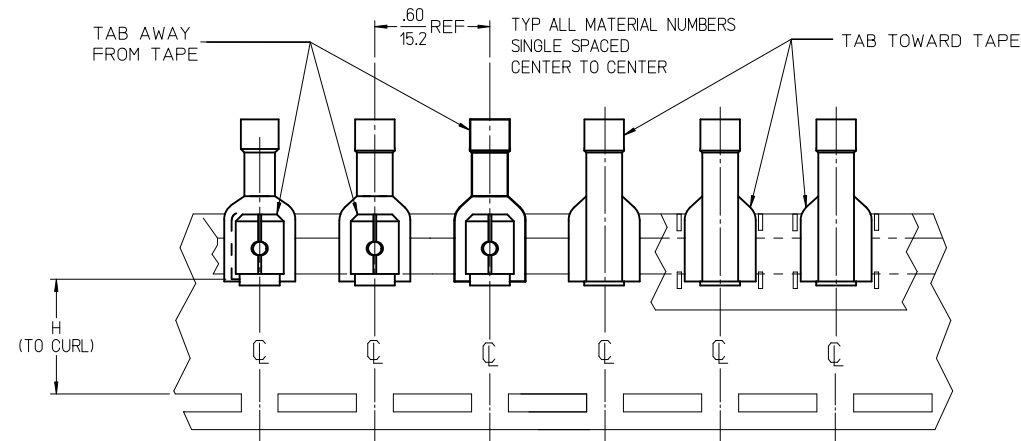

PARTS ON TAPE
(SCALE 2:1)

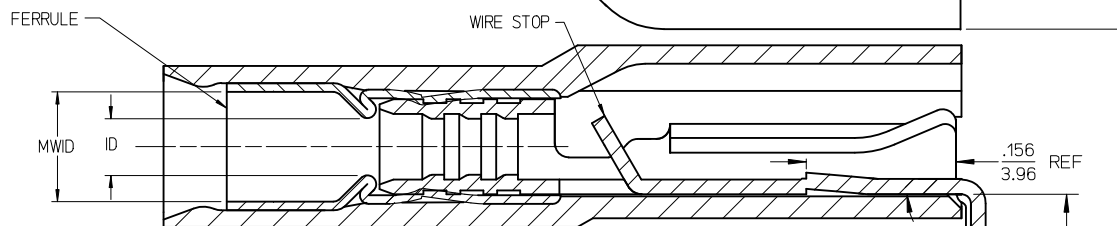
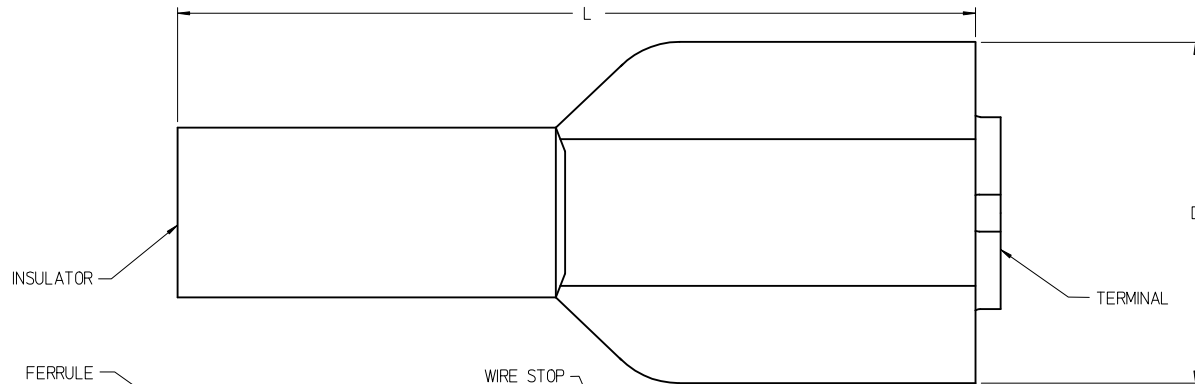
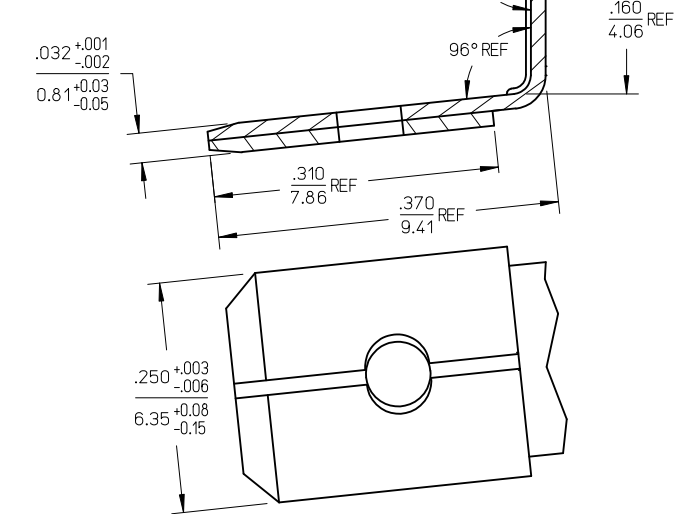

NOTES:

1. TERMINAL MATERIAL: BRASS
2. TERMINAL FINISH: TIN PLATED
3. INSULATOR MATERIAL: NYLON
4. FERRULE MATERIAL: COPPER ALLOY (D)
5. FERRULE FINISH: TIN PLATED
6. MWID = MAXIMUM WIRE INSULATION DIAMETER.
7. ASSEMBLY IS ROHS COMPLIANT.

FERRULE MATERIAL DESCR EC NO: MNA2009-0510 DRAWN:THRODAHL 2010/01/04 CHKD:JMACNEIL 2010/01/05 APPR:JMACNEIL 2010/01/05	QUALITY SYMBOLS ▽=0 ▽=0
REV	DESCRIPTION
D	

GENERAL TOLERANCES (UNLESS SPECIFIED)	
mm	INCH
4 PLACES ± --- ± ---	
3 PLACES ± --- ± ---	
2 PLACES ± --- ± ---	
1 PLACE ± --- ± ---	
ANGULAR ± ---°	
DRAFT WHERE APPLICABLE MUST REMAIN WITHIN DIMENSIONS	

DIMENSION STYLE IN/MM	
DRAWN BY DAY	DATE 1997/08/21
CHECKED BY RWD	DATE 1997/08/21
APPROVED BY RWD	DATE 1997/08/21
MATERIAL NO. SEE CHART	
SIZE C	

SCALE ---	DESIGN UNITS INCH	THIRD ANGLE PROJECTION
TITLE PIGGYBACK FIQD, .250 X .032 TAB, AVIKRIMP		
MOLEX INCORPORATED		SHEET NO. 1 OF 1
DOCUMENT NO. SD-19602-001		
THIS DRAWING CONTAINS INFORMATION THAT IS PROPRIETARY TO MOLEX INCORPORATED AND SHOULD NOT BE USED WITHOUT WRITTEN PERMISSION		