

MODEL NUMBER
ADT-2591-7M-SCM-02

NOTES:

1.0 MATERIALS:

- 1.1 HOUSING: STAINLESS STEEL PER ASTM-A582, TYPE 303.
- 1.2 CENTER CONTACT: BERYLLIUM COPPER ROD ALLOY C172, PER ASTM-B194.
- 1.3 DIELECTRIC: PTFE FLUOROCARBON PER

2.0 PLATING:

- 2.1 HOUSING: PASSIVATED PER MIL-F-14072 AND QQ-P-35
- 2.2 CENTER CONTACT: GOLD PER MIL-G-45204, TYPE II, CLASS 2.
- 2.3 7MM NUT: ELECTROPOLISH (BRIGHT POLISH)

3.0 ELECTRICAL SPECIFICATION:

- 3.1 FREQUENCY RANGE: DC to 8.0 GHz
- 3.2 VSWR (MAXIMUM):
DC to 4.0 GHz: 1.04:1
4.0 to 8.0 GHz: 1.07:1

4.0 DIMENSIONS IN PARENTHESIS ARE IN MILLIMETERS

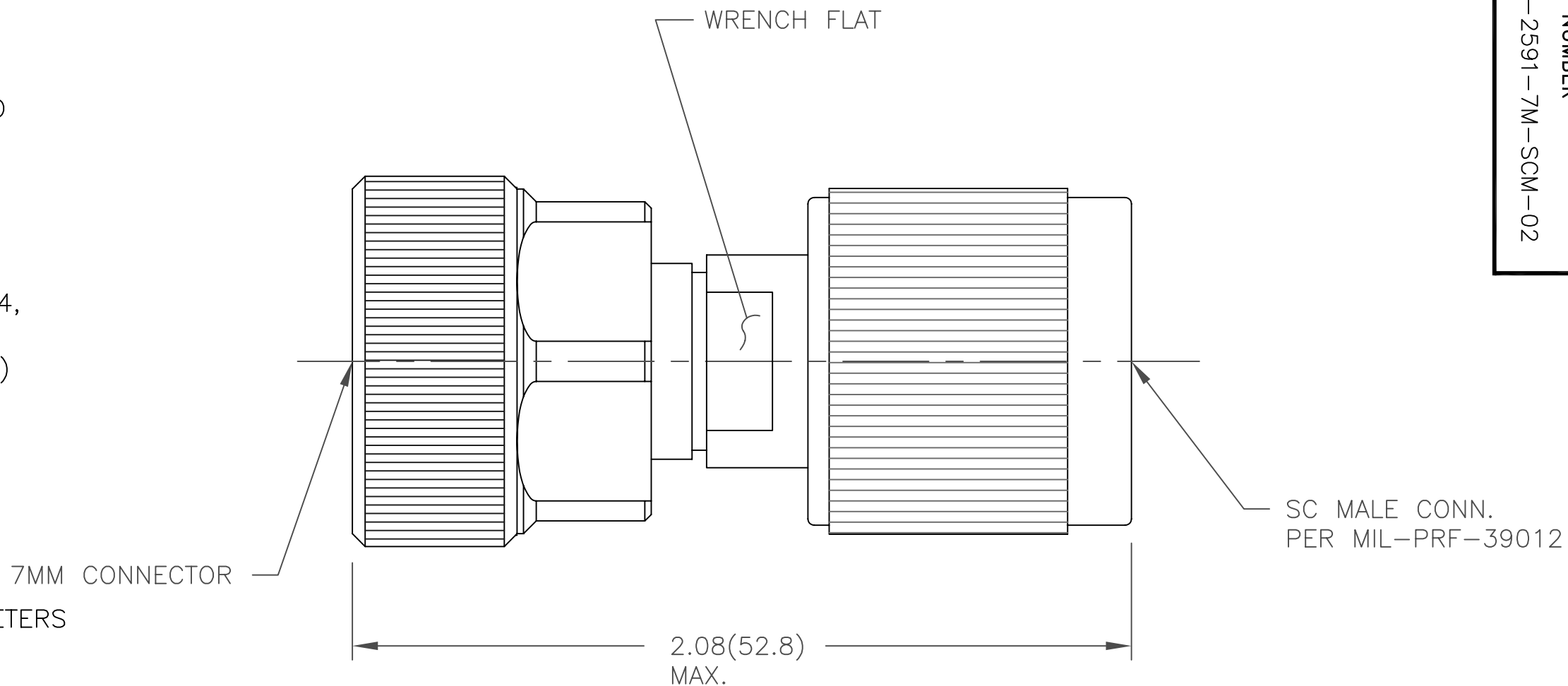

DWG NO. WAS: 02397-01-00

REV.	DESCRIPTION	DATE
-	RELEASED	3/31/92
A	ECR 6545	6/29/89
B	REDRAW ON CAD	3/31/92
C	ECN 14164	12/27/94
C1	ADDED TITLEBLOCK	3/9/05

NOTICE: The information contained in this drawing is proprietary and must not be used without the permission of Emerson Network Power. UNLESS OTHERWISE NOTED DIMENSIONS ARE IN INCHES AND TOLERANCES ARE: 3 PLACE DECIMALS ±.005 2 PLACE DECIMALS ±.02 FRACTIONS ±1/64 PARALLELITY: T.I.R. _____ FLATNESS: T.I.R. _____ CONCENTRICITY: T.I.R. _____ ANGLES AND PERPENDICULARITY: ±1°	CAGE CODE 34078	MIDWEST MICROWAVE	
			TITLE ADAPTER OUTLINE DRAWING
DRAWN/DATE A.BEATTY 3/31/92	ENG./DATE A.OSGA 4/15/92	DRAWING NUMBER ADT-2591-7M-SCM-02-01	REV. C1
CHECKED/DATE A.BEATTY 3/31/92	APPROVED/DATE	SCALE: 3=1	SHEET 1 of 1