

THIS DRAWING IS A CONTROLLED DOCUMENT FOR AMP INCORPORATED. IT IS SUBJECT TO CHANGE AND THE CONTROLLING ENGINEERING ORGANIZATION SHOULD BE CONTACTED FOR THE LATEST REVISION.

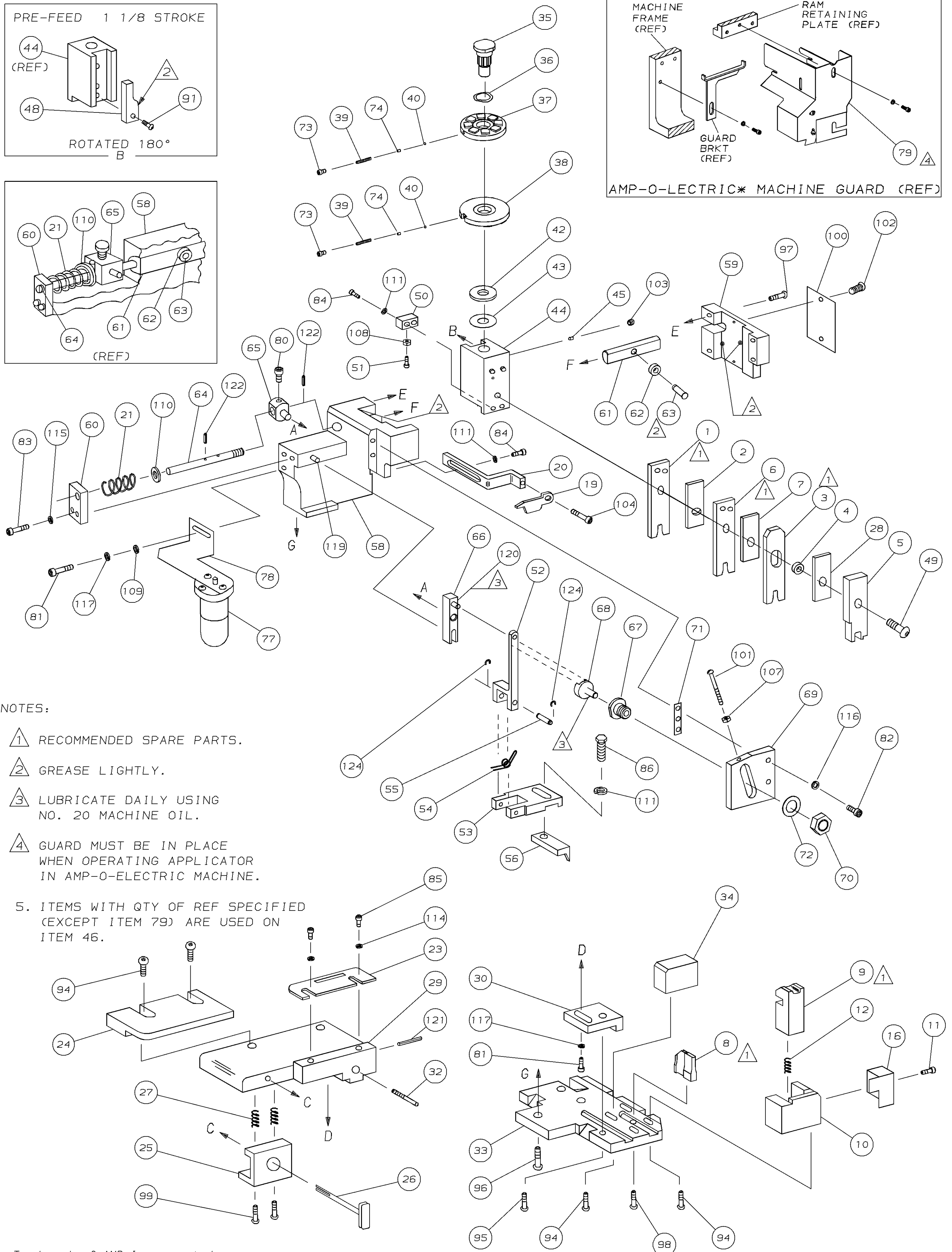
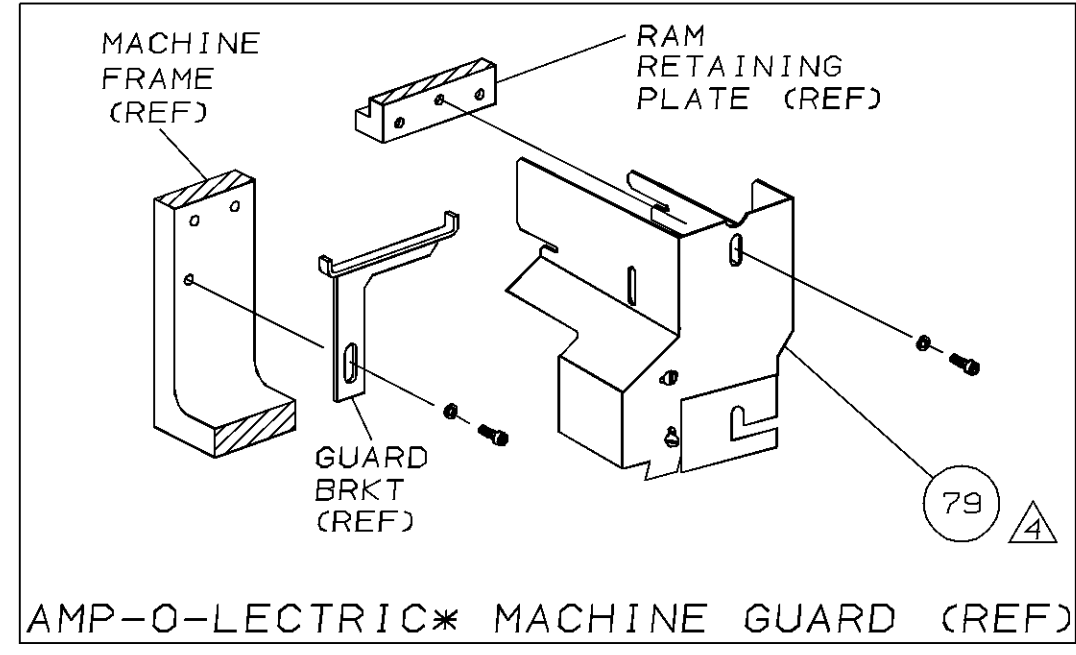
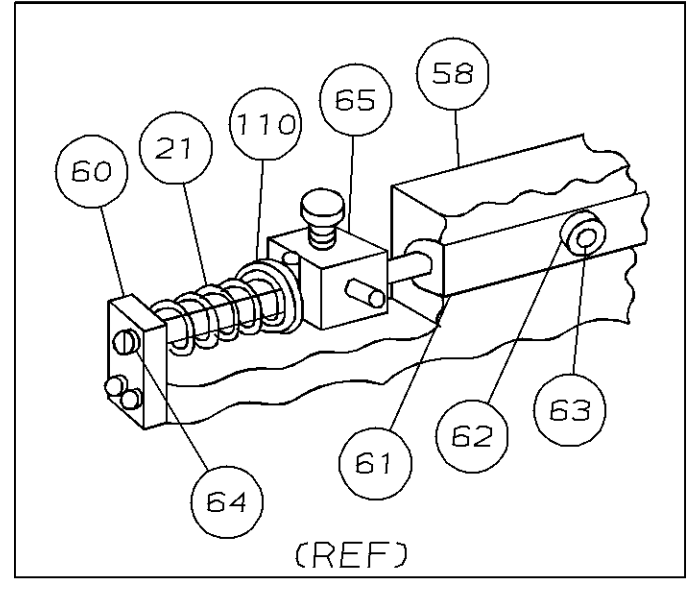
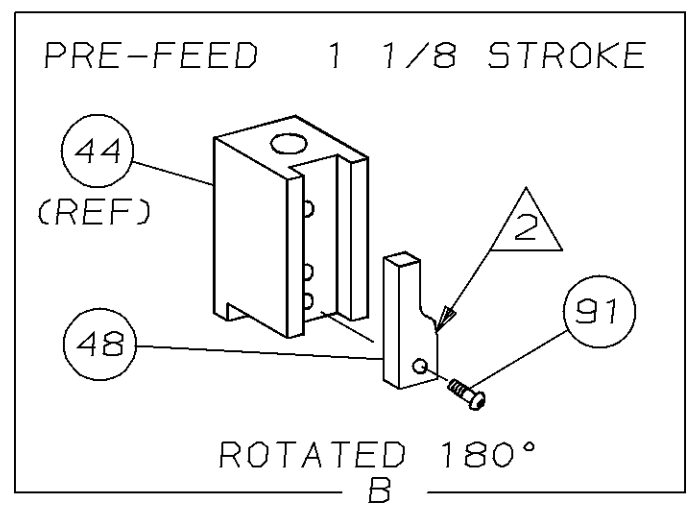

- NOTES:
- 1 RECOMMENDED SPARE PARTS.
 - 2 GREASE LIGHTLY.
 - 3 LUBRICATE DAILY USING NO. 20 MACHINE OIL.
 - 4 GUARD MUST BE IN PLACE WHEN OPERATING APPLICATOR IN AMP-O-ELECTRIC MACHINE.
 - 5. ITEMS WITH QTY OF REF SPECIFIED (EXCEPT ITEM 79) ARE USED ON ITEM 46.

THIS INFORMATION IS CONFIDENTIAL AND IS DISCLOSED TO YOU ON CONDITION THAT NO FURTHER DISCLOSURE IS MADE BY YOU TO OTHER THAN AMP PERSONNEL WITHOUT WRITTEN AUTHORIZATION FROM AMP INCORPORATED, HARRISBURG, PA.

REF	21045-3	RING, RET "C" (.187ø) FEED FINGER PIN	124	REF	454220-1	CAP, HOUSING	59
			123	REF	454485-1	HOUSING	58
REF	5-21028-1	PIN, SLT SPR (.125øx.50) ADJ ROD	122				57
1	4-21028-0	PIN, SLT SPR (.093øx.75) ST GUIDE PL	121	1	690542-2	PAWL, FEED	56
REF	1-21030-1	PIN, DOWEL (.187øx.50) LEVER	120	REF	240624-1	PIN, FEED FINGER	55
REF	1-21030-6	PIN, DOWEL (.187øx1.25) HOUSING	119	REF	691499-1	SPRING, FEED FINGER	54
			118	REF	690541-1	FINGER, FEED	53
2	21024-5	WASHER, LOCK (NO. 10) ADJ BLOCK	117	REF	455679-1	LEVER, TERMINAL FEED ARM	52
REF	21024-5	WASHER, LOCK (NO. 10) ADJ PLATE	116	1	811242-2	BUMPER, HOLDDOWN	51
REF	21024-5	WASHER, LOCK (NO. 10) FEED GUIDE ROD	115	1	690753-1	SPACER, TONKER	50
2	21024-2	WASHER, LOCK (NO. 4) FRONT STRIP GUIDE	114	1	7-21002-9	BOLT, CRIMPER (5/16-24x1.00)	49
			113	1	690602-5	CAM, PRE-FEED 1 1/8 STROKE	48
			112				47
4	21024-4	WASHER, LOCK (NO. 8) STRIPPER	111	1	459456-1	APPLICATOR, BASIC (SUBASSY)	46
REF	21899-4	WASHER, FLAT (5/16 DIA) SCREW ADJ	110	1	690191-1	PLUG, NYLON	45
1	21899-2	WASHER, FLAT (NO. 10) LUB ASSY	109	1	455673-1	RAM	44
1	21018-5	NUT, HEX (NO. 6) HOLDDOWN	108	1	690125-1	WASHER, LAMINATED	43
REF	21018-5	NUT, HEX (6-32) FEED ADJ	107	1	690124-1	WASHER, RAM	42
			106				41
			105	2	23241-6	BALL, STEEL	40
1	456567-1	SCR, SHLD (.188øx.125) STRIPPER	104	2	690170-1	SPRING, COMPRESSION	39
1	21009-2	SCR, SKT SET (1/4-20x.25) LOC-WEL) RAM	103	1	690142-1	DISC, INSULATION	38
2	21017-2	SCR, DRIVE (#2x.19) ID PLATE	102	1	2-692155-1	DISC, WIRE	37
REF	6-23715-5	SCR, PAN HD (6-32x1.50) FEED ADJ	101	1	22480-5	WASHER, SPRING	36
1	461264-1	PLATE, IDENTIFICATION	100	1	690212-1	POST, RAM	35
2	2-21002-9	SCR, BHC (10-32x.75) DRAG	99	1	690786-3	SUPPORT, TERMINAL	34
1	227233-8	SCR, BHC (8-32x.38) LOC-WEL) ANVIL	98	REF	455675-1	PLATE, BASE	33
REF	2-21002-9	SCR, BHC (10-32x.75) CAP	97	1	690432-3	SCREW, ADJUSTMENT	32
REF	2-22733-8	SCR, BHC (1/4-20x.62) HOUSING	96				31
REF	2-21002-7	SCR, BHC (10-32x.50) SG ADJ BLOCK	95	REF	455689-1	BLOCK, STRIP GUIDE ADJ	30
6	2-21002-2	SCR, BHC (8-32x.50) SHEAR	94	1	455671-1	PLATE, STRIP GUIDE	29
			93	1	455888-6	SPACER, FRONT SHEAR DEP	28
			92	2	1-22284-0	SPRING, DRAG	27
1	1-21002-7	SCR, BHC (6-32x.38) CAM	91	1	690546-1	LEVER, DRAG RELEASE	26
			90	1	240792-1	DRAG, STOCK	25
			89	1	9-690504-4	GUIDE, STRIP (REAR)	24
			88	1	690438-1	GUIDE, STRIP (FRONT)	23
			87				22
1	2-22603-0	SCR, HEX HEAD (8-32x.31) FEED FINGER	86	REF	4-22284-9	SPRING, FEED RETURN	21
2	1-21000-3	SCR, SKT CAP (4-40x.25) F STRIP GUIDE	85	1	458950-1	ARM, STRIPPER	20
3	2-21000-7	SCR, SKT CAP (8-32x.50) STRIPPER	84	1	458949-1	STRIPPER	19
REF	3-21000-7	SCR, SKT CAP (10-32x.75) FEED ROD GD	83				18
REF	3-21000-6	SCR, SKT CAP (10-32x.62) FEED ADJ BLK	82				17
2	3-21000-4	SCR, SKT CAP (10-32x.38) SG ADJ BLK	81	1	691667-1	GUARD, CHIP (FRONT)	16
REF	3-21000-4	SCR, SKT CAP (10-32x.38) PIVOT BLOCK	80				15
REF	449755-1	GUARD WINDOW	79				14
1	1-465184-0	LUBRICATOR ASSY	78				13
1	22014-1	OIL, SYNTHETIC	77	1	5-22280-0	SPRING, SHEAR	12
			76	1	690461-1	STOP, SHEAR	11
			75	1	690459-1	HOLDER, SHEAR (FRONT)	10
2	690603-1	SPRING, ASSIST	74	1	454276-1	SHEAR, FLOAT (FRONT)	9
2	23030-1	SCR, SKT CAP (6-32x.25) CP DISC	73	1	854014-5	ANVIL	8
REF	458109-1	WASHER, SPECIAL	72	1	455888-1	SPACER, CRIMPER	7
REF	690517-1	SPACER	71	1	461679-5	CRIMPER, STABILIZER	6
REF	22594-8	NUT, HEX	70	1	1-455889-4	DEPRESSOR, SHEAR (FRONT)	5
REF	240628-1	PLATE, ADJUSTMENT	69	1	238011-7	SPACER, TUBULAR	4
REF	240626-1	SHAFT, PIVOT	68	1	456134-5	CRIMPER, INSULATION	3
REF	240633-1	BUSHING	67	1	455888-7	SPACER, CRIMPER	2
REF	455680-1	LEVER, INTERMEDIATE	66	1	3-456406-0	CRIMPER, WIRE	1
REF	240629-1	BLOCK, PIVOT	65				
REF	240632-2	SCREW, ADJUSTMENT FEED ROD	64				
REF	240659-3	PIN, CAM ROLLER	63				
REF	240658-1	ROLLER, CAM	62				
REF	454398-2	ROD, FEED	61				
REF	454178-1	GUIDE, FEED ROD	60				

REMARKS	NO	REV
APPL USED ON MACHINE PART NO	MACH SERIAL NO	DISTRIBUTION
CUSTOMER NAME	APPL SERIAL NO	ORIGINAL
ADDRESS	PURCHASE ORDER	CUSTOMER COPY
CITY	ENG APP	FIELD ENG COPY

CRIMPING DATA				APPLICATOR WILL APPLY	
PAD LTR	CRIMP HEIGHT	WIRE SIZE	WIRE STRIP LENGTH		
A	.059	16		170353-1	
B	.053	18		170353-2	
C	.048	20			
D	NOT USED	20			
CRIMP SIZE	TYPE	FEED	APPL INST		
WIRE .090	F	.472	AI 8040		
INSUL .130	F				
WIRE RANGE	INSULATION RANGE	MACHINE NO			
20-16	.079-.114	565435-5			

AMP-O-ELECTRIC
PRE-FEED

1 1

SET UP GAGE	10-1	458637-1	L1387	AMP INCORPORATED
DR	9/11/90	APP	9-20-90	Harrisburg, Pa.
P. WATHIAS		BY	WOLFE	
CHK	9-20-90	REL	9-20-90	
C. ERISMAN		B. MEYERSON		
NAME	MINIATURE QUICK CHANGE APPLICATOR		LOC	D
	SIDE FEED (PULSE LOCK CONTACT)		NO	567379-2
			REV	A