

Automotive & Industrial Grade Ceramic Base SMD Crystal



ABM10AIG



2.5 x 2.0 x 0.55 mm
RoHS/RoHS II Compliant
 MSL = N/A: Not Applicable

Features

- AEC-Q200 Qualified
- Automotive Grade 1: -40°C to +125°C
- Automotive Grade 0: -40°C to +150°C (Available Upon Request)
- TS16949 Production Line Certified
- PPAP Available Upon Request
- Hermetically Seam-sealed Ceramic Package
- RoHS/RoHS II Compliant and Pb free

Applications

- Infotainment Systems
- Keyless Entry & Startup
- GPS & Navigation
- Comfort control
- ADAS (Advanced Driver Assistance Systems)
- Vehicle to Vehicle Communication
- LiDAR (Light Detection and Ranging)
- In-vehicle Networking
- Powertrain & Drive Control
- Power Control & Conversion
- Industrial Control & Automation

Electrical Specifications

Parameters	Min.	Typ.	Max.	Units	Notes
Frequency Range	12.000		62.500	MHz	
Operation Mode	Fundamental				
Operating Temperature ^[Note 1]	-40		+125	°C	Option "blank"; See options
	-40		+150		Option "V"; See options
Storage Temperature ^[Note 1]	-40		+125	°C	Option "blank, J, D, N"
	-40		+150		Option "V"
Frequency Tolerance @ +25°C	-50		+50	ppm	Option "blank"; See options
Frequency Stability over the Operating Temperature (ref. to +25°C)	-100		+100	ppm	Option "blank"; See options
	-150		+150		Option "R"; See options
Equivalent series resistance (R1)			150	Ω	12.000-15.999 MHz
			80		16.000-19.999 MHz
			60		20.000-29.999 MHz
			50		30.000-34.999 MHz
			40		35.000-62.500 MHz
Shunt capacitance (C0)			2.0	pF	
Load capacitance (CL)		10		pF	Option "blank"; See options
Drive Level		10	100	μW	
Aging	-2		+2	ppm	@25°C± 3°C First year
Insulation Resistance	500			MΩ	@100 Vdc ± 15V

Note 1: Operating temperature range option -40°C to +150°C only available in select frequencies and electrical performance options. Please contact Abracon for availability.



5101 Hidden Creek Ln Spicewood TX 78669
 Phone: 512-371-6159 | Fax: 512-351-8858
 For terms and conditions of sales, please visit:
www.abracon.com

REVISED: 06-14-19

ABRACON IS
 ISO9001-2015
 CERTIFIED

Automotive & Industrial Grade Ceramic Base SMD Crystal



ABM10AIG



2.5 x 2.0 x 0.55 mm
RoHS/RoHS II Compliant
 MSL = N/A: Not Applicable

Options and Part Identification (left blank if standard)

ABM10AIG- [] MHz - [] - [] - [] [] [] - []

Frequency in MHz
 Please specify the frequency in MHz. (e.g. 14.31818MHz)

Load Capacitance (pF)
 Blank: 10pF
 If not standard, please specify CL in pF or S for series

Custom ESR if other than standard
 R □: Specify a value in Ω (e.g.: R80)

Packaging
 Blank: Bulk
 T: 1k pcs / reel
 T3: 3k pcs / reel

Operating Temp.
 Blank: -40°C to +125°C
 N: -30°C to +85°C
 D: -40°C to +85°C
 J: -40°C to +105°C
 V: -40°C to +150°C (*)

(*) Contact Abracon for Availability

Freq. Tolerance
 Blank: ± 50 ppm
 4: ± 30 ppm
 3: ± 25 ppm
 2: ± 20 ppm
 7: ± 15 ppm
 1: ± 10 ppm

Freq. Stability
 Blank: ± 100 ppm
 R: ± 150 ppm
 Z: ± 50 ppm
 P: ± 45 ppm (*)
 F: ± 40 ppm (*)
 H: ± 35 ppm (*)
 Y: ± 30 ppm (*)
 W: ± 25 ppm (*)
 X: ± 20 ppm (*)
 G: ± 15 ppm (*)

(*) Contact Abracon for Availability



ABM10AIG



2.5 x 2.0 x 0.55 mm
 RoHS/RoHS II Compliant
 MSL = N/A: Not Applicable

Mechanical Dimensions

Top View

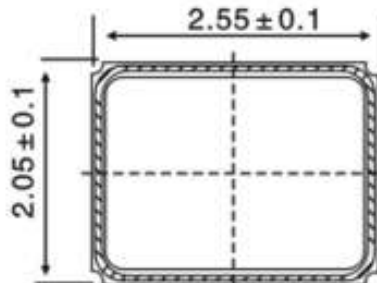

Side View



Bottom View

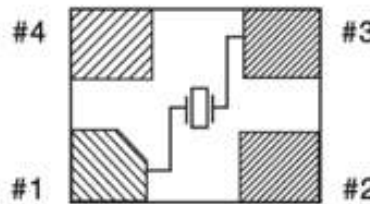
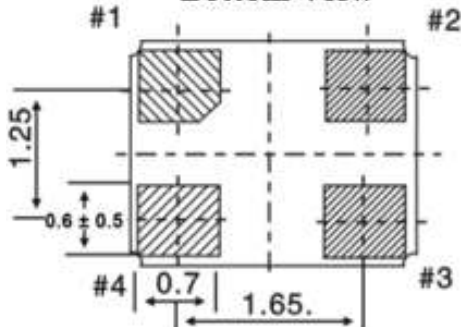

Pin #1: Crystal
 Pin #3: Crystal

Pin #2: GND (*)
 Pin #4: GND (*)

(*) Electrically connected to lid

Recommended Land Pattern

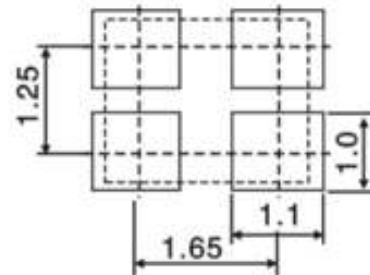

Note: Due to availability of raw materials, this part may be manufactured with the chamfer on pin 1 or pin 4. Be advised that this does not affect the electrical characteristics of the crystal in any way.

Dimensions: mm



ABM10AIG



2.5 x 2.0 x 0.55 mm
 RoHS/RoHS II Compliant
 MSL = N/A: Not Applicable

Reflow Profile

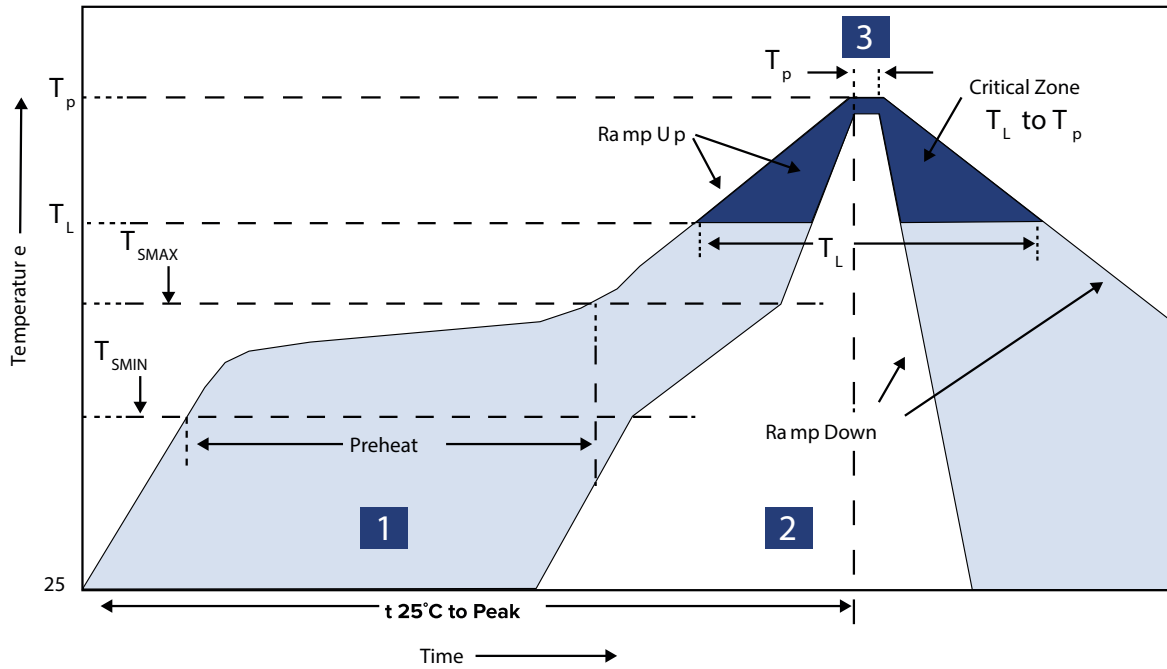

Zone	Description	Temperature	Time
1	Preheat / Soak	$T_{SMIN} \sim T_{SMAX}$ 150°C ~ 180°C	60 ~ 120 sec.
2	Reflow	T_L 230°C	30 ~ 40 sec.
3	Peak heat	T_P 260°C ± 5°C	10 sec. MAX



ABM10AIG



2.5 x 2.0 x 0.55 mm
 RoHS/RoHS II Compliant
 MSL = N/A: Not Applicable

Packaging

Tape and Reel:
 T: 1,000pcs/reel
 T3: 3,000pcs/reel

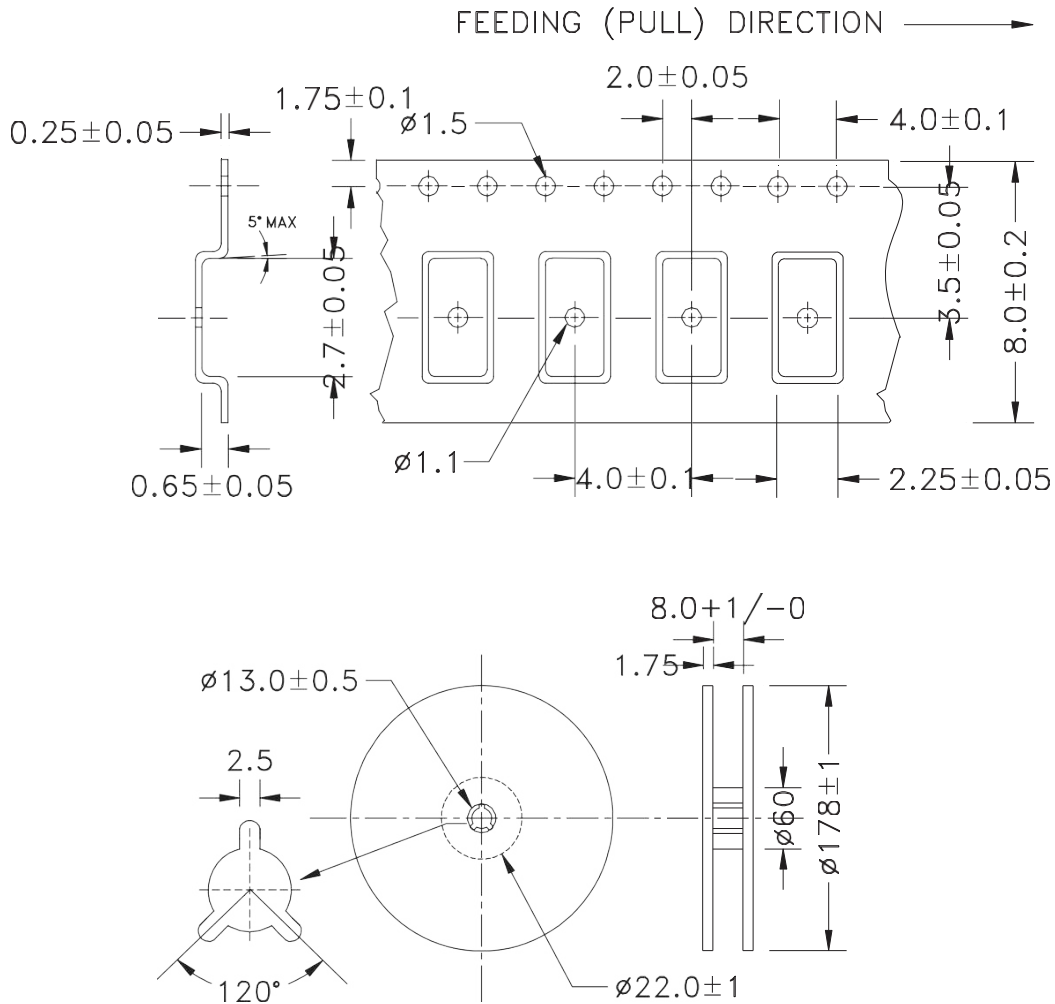

Dimensions: mm

ATTENTION: Abracon LLC's products are COTS – Commercial-Off-The-Shelf products; suitable for Commercial, Industrial and, where designated, Automotive Applications. Abracon's products are not specifically designed for Military, Aviation, Aerospace, Life-dependent Medical applications or any application requiring high reliability where component failure could result in loss of life and/or property. For applications requiring high reliability and/or presenting an extreme operating environment, written consent and authorization from Abracon LLC is required. Please contact Abracon LLC for more information.