

LENGTH TABLE

MATERIAL NO.	NO. CIRCUITS	DIM "A"	DIM "B"
	02	31.8 (1.25)	15.00 (.591)
	03	46.8 (1.84)	30.00 (1.181)
39920-0404	04	61.8 (2.43)	45.00 (1.772)
	05	76.8 (3.02)	60.00 (2.362)
	06	91.8 (3.61)	75.00 (2.952)
39920-0407	07	106.8 (4.20)	90.00 (3.543)
	08	121.8 (4.79)	105.00 (4.134)
	09	136.8 (5.38)	120.00 (4.724)
	10	151.8 (5.97)	135.00 (5.315)
	11	166.8 (6.57)	150.00 (5.906)
	12	181.8 (7.16)	165.00 (6.496)

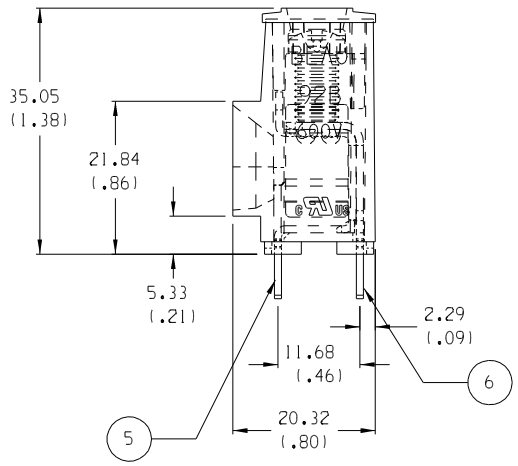
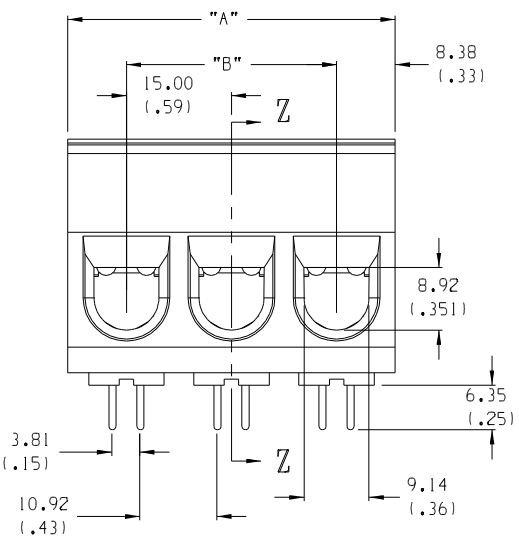
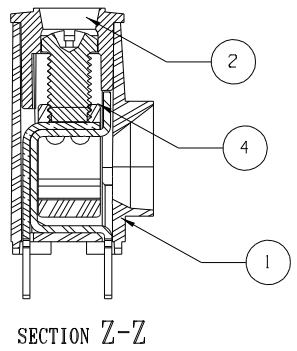
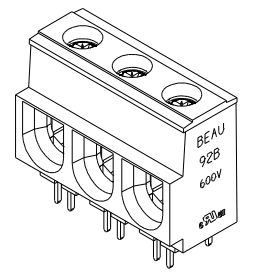
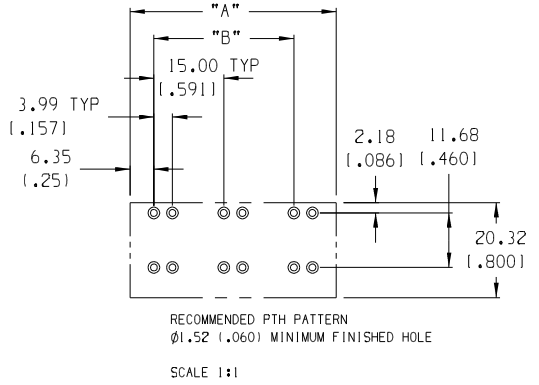
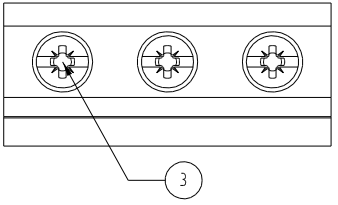

- NOTES:
1. MATERIAL: SEE TABLE.
  2. FINISHES: SEE TABLE.
  3. PRODUCT SPECIFICATION: NOT REQUIRED.
  4. PACKAGING: NOT REQUIRED.
  5. MATES WITH: NONE.
  6. ALL FEATURES ARE TYPICAL UNLESS OTHERWISE NOTED.

7. "XX" REFERS TO THE NUMBER OF CIRCUIT POSITIONS
8. DESIGNED TO MEET NEC & UL 1059 CLASS C 600 VOLTS
9. MULTIPLE TAIL DESIGN FOR LOWER PCB CURRENT DENSITIES
10. PROVEN PRESSURE CLAMP STYLE CONNECTION
11. AVAILABLE IN VARIOUS LENGTHS
12. WINDOW ACCEPTS 133/23 STRANDED #2 AWG, #3 AWG AND 19 STRAND #1 AWG

ITEM	QTY.	DESCRIPTION	MATERIAL	FINISH
6	"XX"	OUTER TERMINAL	COPPER	TIN
5	"XX"	INNER TERMINAL	COPPER	TIN
4	"XX"	CAGE	BRASS	NICKEL
3	"XX"	SCREW, 1/4-28, POZI-SLOT	BRONZE	TIN
2	1	COVER	THERMOPLASTIC	BLACK
1	1	BODY	THERMOPLASTIC	BLACK

EC NO. ECN# 3987  
 DRWN: CY 01-14-05  
 CH'KT  
 APPR:  
 C

DESCRIPTION  
 REV

QUALITY SYMBOLS  
 MAJOR  
 CRITICAL

GENERAL TOLERANCES: (UNLESS SPECIFIED)

	mm	INCH
4 PLACES		±.0015
3 PLACES	±.038	±.005
2 PLACES	±.13	±.01
1 PLACE	±.3	

ANGULAR: ±2°

DRAFT WHERE APPLICABLE MUST REMAIN WITHIN DIMENSIONS

SCALE 1.5:1  
 DESIGN UNITS:  mm  INCH  
 THIRD ANGLE PROJECTION  
 DRAWN BY & DATE: R. KEMP 4-14-04  
 CHECKED BY & DATE: AMP 4-14-04  
 APPROVED BY & DATE: G. ROBERTSON 4-14-04  
 CAD FILENAME: 92B05XX

DIMENSIONS:  mm  INCH  mm ONLY

SHT	REV
1	-

REVISE ON CAD ONLY

TITLE: SR, BTS, #1-#8 AWG, 600V, POZI-SLOT

**MOLEX INCORPORATED**

MATERIAL NO.	DRAWING NO.	SHEET NO.
SEE CHART	SD-39920-007	1 OF 1

THIS DRAWING CONTAINS INFORMATION THAT IS PROPRIETARY TO MOLEX INCORPORATED AND SHOULD NOT BE USED WITHOUT WRITTEN PERMISSION.

SIZE B