

THIS DRAWING IS UNPUBLISHED. RELEASED FOR PUBLICATION
 © COPYRIGHT BY TYCO ELECTRONICS CORPORATION. ALL INTERNATIONAL RIGHTS RESERVED.

DESIGNED FOR USE WITH RG-142/U CABLE	LOC AJ	DIST 00
CABLE ENTRY DIAMETER MINIMUM		
HOUSING	.119	
CONTACT	.040	
FERRULE	.216	

REVISIONS					
P	LTR	DESCRIPTION	DATE	DWN	APVD
B		REV PER ECO 07-004710	12-03-07	DW	KW
C		REVISED PER ECO-08-030676	25-02-09	AEG	JKO

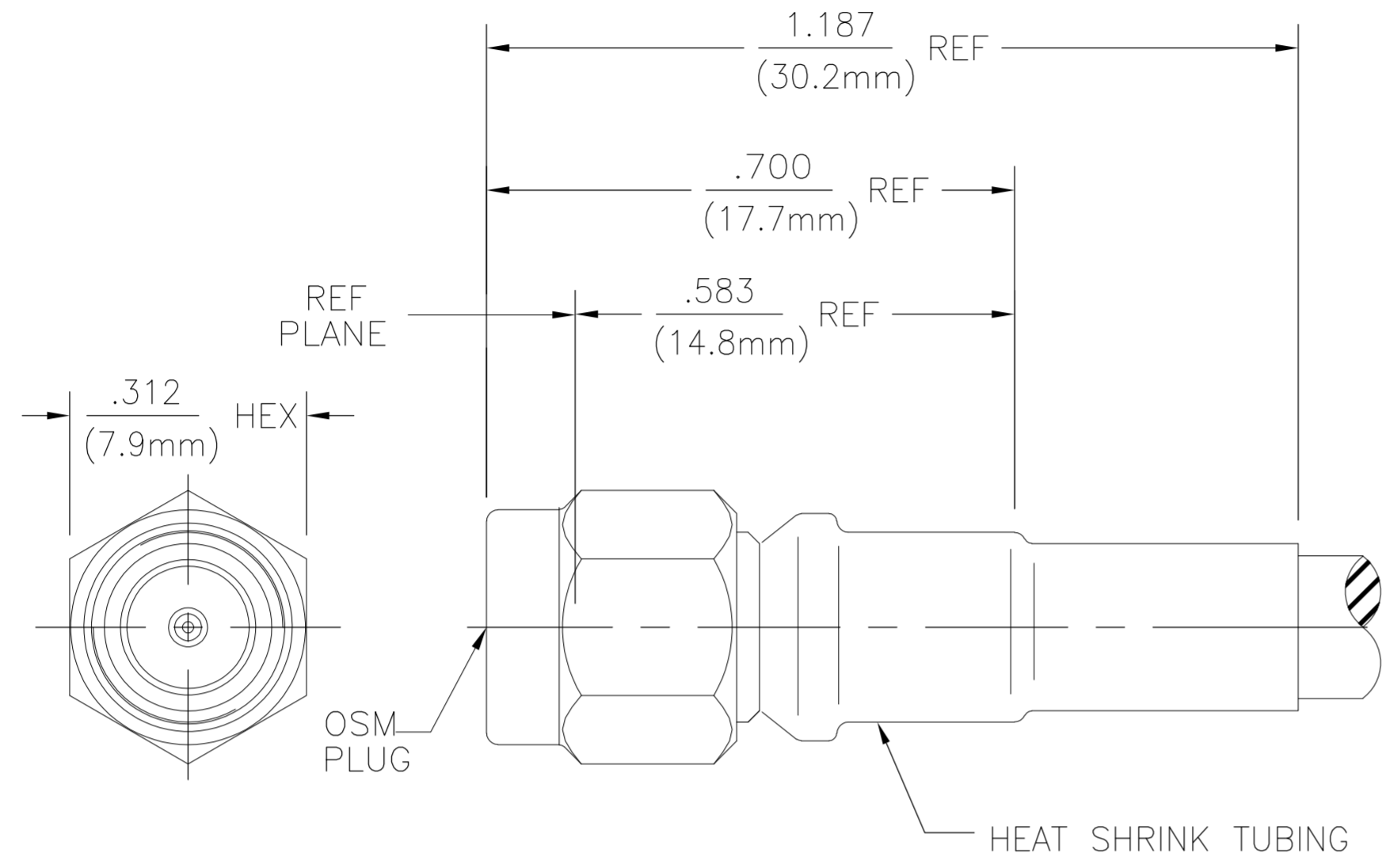

- ① BRASS
- ② STAINLESS STEEL
- ③ BERYLLIUM COPPER
- ④ PTFE
- ⑤ GOLD PLATE
- ⑥ POLYOLEFIN COMPOUND
- ⑦ SILICONE RUBBER
- ⑧ BRASS OR COPPER

ELECTRICAL	MECHANICAL	ENVIRONMENTAL
Nominal Impedance (Ohms) 50	Interface Dimensions MIL-STD-348A, Fig. 310.1	TEMPERATURE RATING -62°C TO +165°C
Frequency Range (GHz) DC to 12.4	Recommended Mating Torque 7 to 10 in-lbs	Vibration MIL-STD-202, Method 204, Condition D.
Volt Rating (VRMS MAX) @ Sea Level 335	Mating Characteristics: Insertion (MAX Lbs) N/A	Shock MIL-STD-202, Method 213, Cond I
VSWR 1.15 +.01 f(GHz)	Withdrawal (MIN Oz) N/A	Thermal Shock MIL-STD-202, Method 107, Condition B, EXCEPT HIGH TEMP SHALL BE +85°C
Insertion Loss (dB MAX) .06 √f(GHz)	Force to Engage and Disengage (In-Lbs MAX) 2.0	Moisture Resistance MIL-STD-202, Method 106
RF Leakage (dB MIN) -[60-f(GHz)]	Center Contact Captivation Axial (Lbs) N/A	Corrosion - MIL-STD-202, Method 101, Condition B, 5% salt spray
Dielectric Withstanding Voltage (VRMS MIN) @ Sea Level 1,000	Radial (In-Oz) N/A	
Contact Resistance (Milliohms MAX) Center Contact 2.0	Cable to Housing Retention (lbs MIN) 45	
Outer Contact 2.0	Weight (Grams) TBD	
Cable to Housing 0.5		
RF High Potential @ Sea Level (VRMS MIN @ 5 MHz) 670		
I.R.(Megohms MIN) 10,000		

⑧	⑧⑤	③⑤	①⑤	①	③	①⑤	④	1051650-2
⑥	⑧⑤	③⑤	②⑤	①	③	②⑤	④	1051650-1
SHRINK TUBE	FERRULE	CONTACT	HOUSING	GASKET	RETAINING RING	COUPLING NUT	DIELECTRIC	TE PN

THIS DRAWING IS A CONTROLLED DOCUMENT.		DWN E.J.C 2/21/68	Tyco Electronics Corporation Harrisburg, PA 17105-3608	
DIMENSIONS: INCHES		CHK PRB 2/21/68	NAME OSM STRAIGHT CABLE PLUG CRIMP ATTACHMENT	
TOLERANCES UNLESS OTHERWISE SPECIFIED:		APVD D NANIA 2/27/68	DRAWING NO A2 00779 C=1051650	
0 PLC ± -		PRODUCT SPEC	RESTRICTED TO	
1 PLC ± -		APPLICATION SPEC	-	
2 PLC ± -		WEIGHT	-	
3 PLC ± .005		SCALE	4:1	
4 PLC ± -		SHEET	1 of 1	
ANGLES ± 1°		REV	C	
MATERIAL		CUSTOMER DRAWING		