

On Request

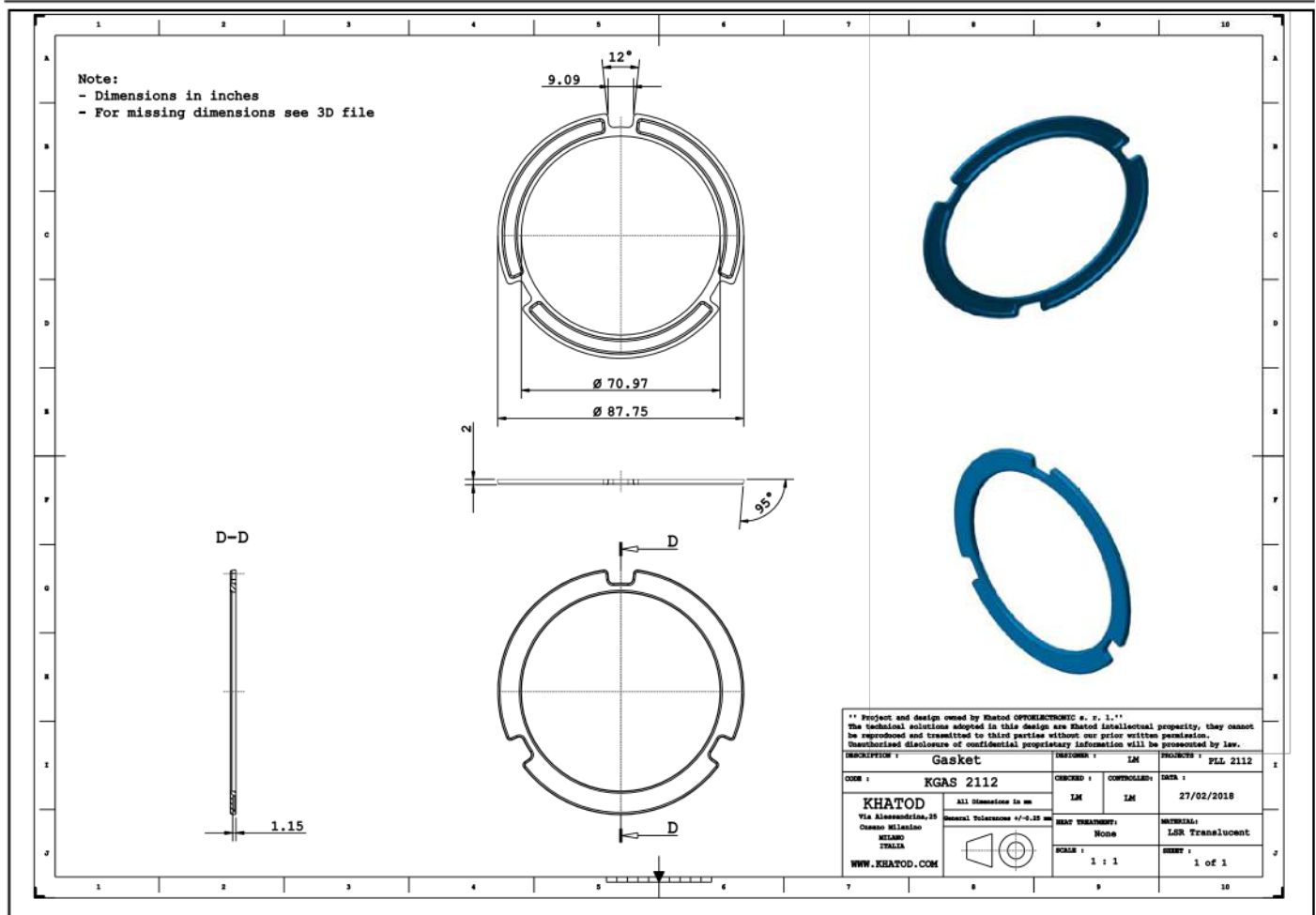

KGAS2112 - Physical Characteristics

Hardness sh A : 65 +/-5	Color : Transparent	Abbrev. : SIL 65H TRASP	
Basic Element : VMQ	Vulcanization: 10min @ 150°C	Annealing : 4 hours@200°C	
Original Parameters	Unit of Measurement	Detected Values	Test Method
Hardness	Shore A	65	ASTM D 2240
Hardness	IRHD		
100% Modulus	MPa		ASTM D 412
100% Modulus	N/mm ²		
Tensile Strength	MPa	9	ASTM D 412
Elongation	%	620	ASTM D 412
Tear resistance	N/mm	30	ASTM D 624/B
Specific Gravity	g/cm ³	1.16	ASTM D 297
Brittleness Point	°C		
TR-TEST TR10	°C		ASTM D 1329
TR TEST TR-30	°C		
Compression Set 25%			
Temperature: 175°C @ 22h	%	27	ASTM D 395/B