

## IR5001 Active ORing Demo Board Evaluation Procedure

International Rectifier • 233 Kansas Street, El Segundo, CA 90245 USA

### Overview

This document describes how to connect and evaluate the supplied IR5001 Active ORing demo board. The purpose of this circuit is to demonstrate the Active ORing function for carrier-class system boards (in which two negative 48V inputs (-36V to -75V range) are OR-ed to provide redundant board power), and to show how the IR5001 can be used to implement Reverse Polarity protection for -48V input DC-DC converters. The front side of the demo board is shown in Fig. 1.

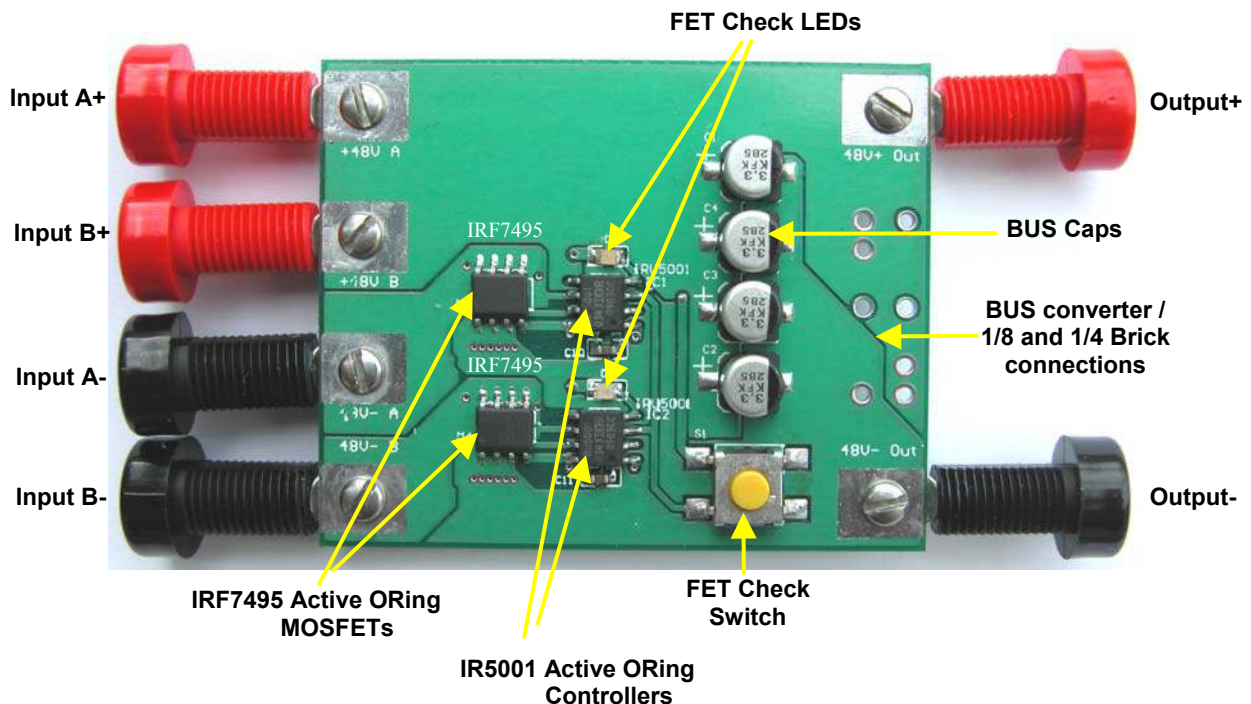

**Figure 1. IRDC5001-LS48V Demo Board**

### Active ORing Demo Board Quick Evaluation Procedure

The circuit schematic is shown in Fig. 2. The circuit incorporates two IR5001 Active ORing ICs (SO8 package), and two IRF7495, 22mOhm, 100V, N-Channel active ORing FETs, also in SO8 package. The power MOSFETs used in this circuit are capable of handling up to 200W of redundant power in 36V to 75V range. For lower power applications, it is recommended to use slightly higher  $R_{ds(on)}$  MOSFETs to enable fastest response time after a reverse current is detected. The IRF7497, 36mOhm, 100V, N-Channel active ORing FET is ideal for 60W applications. As a general design practice, the active ORing FET should be selected to drop approx 50mV during conduction. Eight 3.3uF, 80V aluminum capacitors are connected on the redundant bus.

To evaluate the operation and performance of the active ORing demo board, connect two 48V power supplies to the input terminals (labeled Input A and Input B), and power load to output terminals.

**Caution:** One of the IR5001 functional tests is the response to a short circuit of one of the sources. Before doing this test, it is important that the current limit function of each power supply be checked first. A safe way to test the current limit function is to set the desired current limit, then apply a short with a very low output voltage first (<5V), then remove the short, increase voltage by another 5-10V, apply the short again, and proceed with these steps until the final test voltage is reached. Extra precautions should be taken for older and larger power supplies where the current limit may not be fast enough so that shorting of the outputs can pose safety risks.

The power load can be an electronic load or a resistor. However, a standard 1/4 brick, 1/8 brick, or IR2085S DC Bus Converter demo board can also be used (pin-compatible through-hole solderable connections are provided on the demo board)

To probe the circuit waveforms use an oscilloscope probe with minimal length for the ground pin and connect directly to the pins of the IC / MOSFET device. Any standard current probe & amplifier can be used to measure reverse current flow.

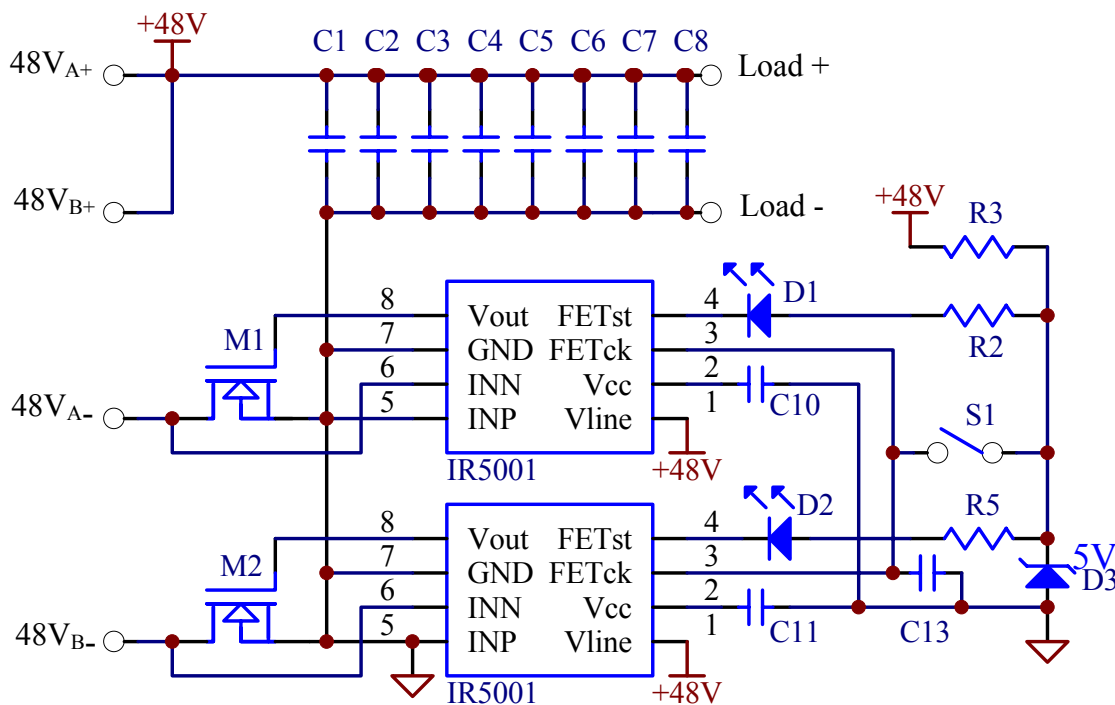

**Figure 2. IR5001 Active ORing Demo Board Schematic**

The procedure for checking the response time of the IR5001 to a simulated short circuit failure of one power source is shown in Fig. 3. The power supply B is set at about 1V higher output voltage than

power Supply A. For example,  $V_B = 49V$ , and  $V_A = 48V$ . This guarantees that power supply B is delivering all the power to the load, while power supply A is on stand by (has zero output current). A 150W IR2085S DC Bus Converter is used on the output of the demo board.

To perform the test, apply a short circuit across the output terminals of power supply B. As the bus voltage drops below 48V (because both power supplies and the redundant bus caps are now shorted), a reverse current will start to flow through the active ORing MOSFET M2 (in line with source B). The IR5001 at source B will detect this reverse current flow and will turn M2 MOSFET off in about 120nS, while allowing only 4A of reverse current flow. This is shown in Fig. 4, which also shows  $V_{ds}$  waveform for the MOSFET M2. When the MOSFET turns off, the energy stored in the stray leakage inductance is dissipated in the avalanche mode that last about 20nS. The calculated avalanche energy is about 5uJ, which is negligible compared to the 180mJ avalanche rating of IRF7495.

Another waveform shown in Fig. 4 is the redundant bus voltage (green trace). With 48V being delivered to a 150W bus converter load, with source B shorted, only 3V bus voltage disturbance is observed.

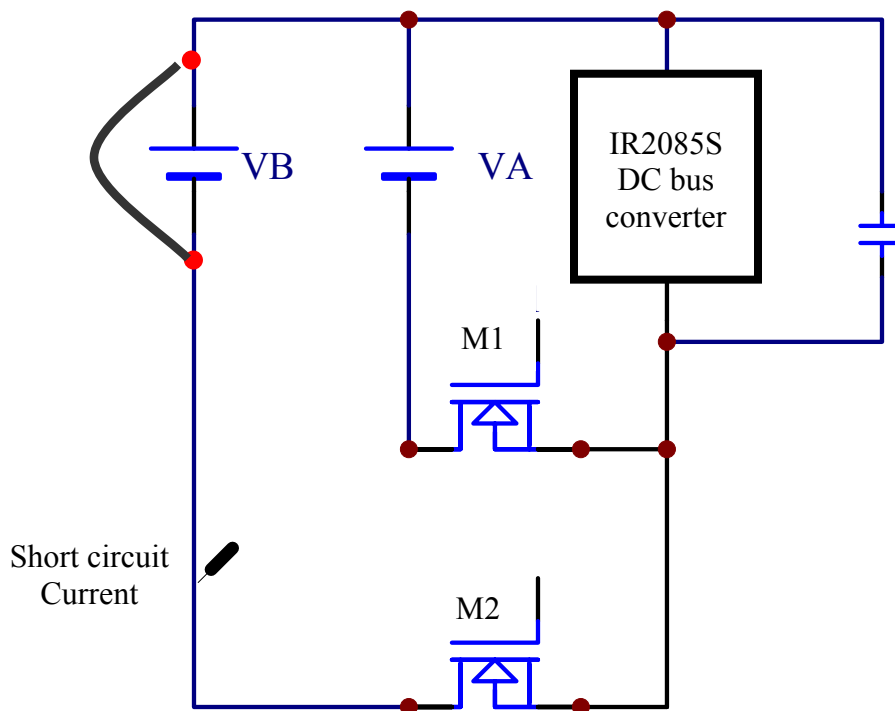

**Figure 3. IR Active ORing function tests**

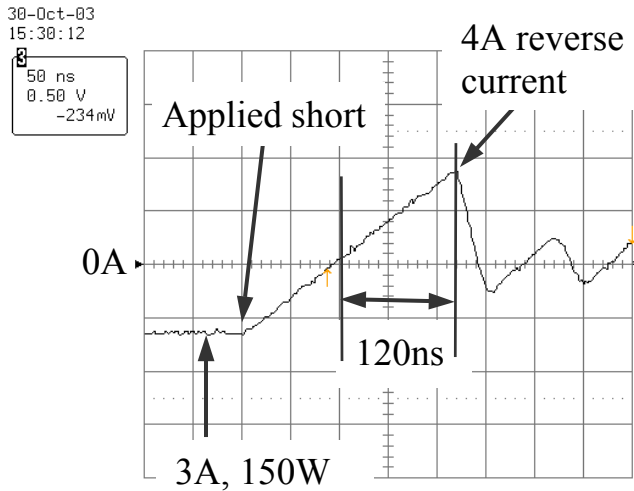

3: MOSFET Ids (2.5A/div)

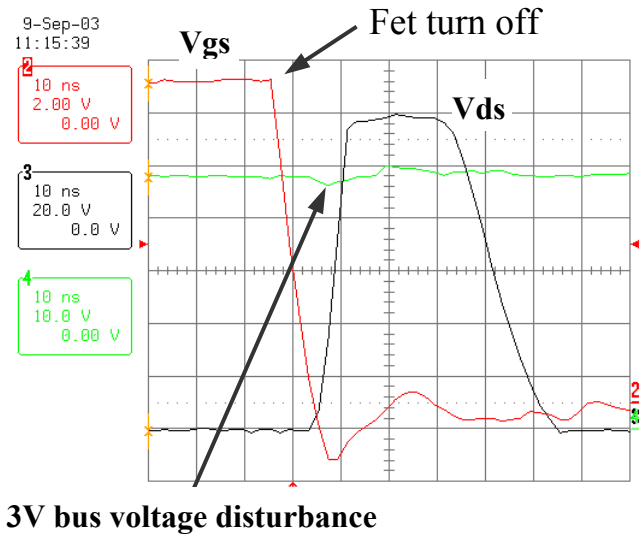

2: MOSFET Vgs, 3: MOSFET Vds; 4: Vbus

**Figure 4. Waveforms during short circuit test for 150W output, 48V input. Power supplies A and B were connected to the demo board with a one foot-long cable. Short circuit was applied on the output terminals of power supply B.**

Another unique feature of the IR5001 is that it allows system designers to assess the power redundancy status on their system boards - whether the ORing FETs are good or not. Applying a logic high at the “FET Check” pin will toggle the output of the IR5001 driver OFF. The desired outcome is that the voltage across the FET, Vds, will rise above 0.3V. When “FET check” is initiated for the MOSFET initially being on, a comparator inside IR5001 compares the Vds voltage to a reference voltage of 0.3V. If the Vds voltage is over 0.3V, the comparator sends a logic-low signal at the “FET Short” pin, indicating that the FET is working properly.

This feature can be tested on this demo board via a normally-OFF switch and two green LEDs. By pressing the switch, the gate drive signals from both Active ORing controllers will be turned off, which will turn off the channels of ORing FETs. The simplest way to test this feature is to disconnect one of the power sources. For example, disconnect V<sub>B</sub> and with V<sub>A</sub> set at 48V, depress the switch. The green LED next to the IC A will turn on. If a short circuit is applied across the FET A, the LED diode will not turn on, indicating a FET short circuit. The same procedure can be used to test the ORing FET for source B (source A would be disconnected, and source B connected).

In a real system, it may not be practical to disconnect one of the sources, and if the voltage of each source cannot be changed, it will only be possible to determine if one of the FETs, which is connected to a higher voltage source, is working properly or not. Usually, a truth table as shown in Table 1, can be applied to determine the status of individual FETs based on various possible status of sources A and B. Note that this table can determine not only if a FET is short, but also if it is open. For additional information on how to use FET Check feature, please contact your local IR Field Applications Engineer.

**Table 1. Truth table for IR5001 “FET Check Feature”**

Case	LED	Initial	During the check		Fet A	Fet B	Comments	
1	A	off	on	Vsd of fet A > 300mV Vsd of fet B < 300mV	good	N/A	VA>VB +0.4V	
	B	off	off					
2	A	off	on	Vsd of fet A > 300mV Vsd of fet B > 300mV	good	good	IVA-VBI < 0.4V	
	B	off	on					
3	A	off	off	Vsd of fet A < 300mV Vsd of fet B < 300mV	Short	N/A	VA>VB+0.3V	
					At least one is short		IVA-VBI < 0.3V	
	B	off	off		N/A	Short	VB>VA+0.3V	
4	A	on	on	Vsd of fet A > 300mV Vsd of fet B > 300mV	Open or diode	good	VA>VB+0.3V	
	B	off	on					
5	A	on	on	Vsd of fet A > 300mV Vsd of fet B < 300mV	Open	Short	VA>VB+0.3V	
	B	off	off		Diode	N/A	IVA-VBI < 0.4V	
6	A	on			Open or diode			
	B	on						