

INTELLIGENT POWER HIGH SIDE SWITCH

Features

- Over temperature shutdown (with auto-restart)
- Short circuit protection (current limit)
- Reverse battery protection (turns On the MOSFET)
- Full diagnostic capability (short circuit to battery)
- Active clamp
- Open load detection in On and Off state
- Ground loss protection
- Logic ground isolated from power ground
- ESD protection

Description

The IPS6041(G)(R)(S)PbF is a five terminal Intelligent Power Switch (IPS) for use in a high side configuration. It features short circuit, over-temperature, ESD protection, inductive load capability and diagnostic feedback. The output current is limited to the Ilim value. The current limitation is activated until the thermal protection acts. The over-temperature protection turns off the device if the junction temperature exceeds the Tshutdown value. It will automatically restart after the junction has cooled 7°C below the Tshutdown value. The reverse battery protection turns On the MOSFET. A diagnostic pin provides different voltage levels for each fault condition. The double level shifter circuitry will allow large offsets between the logic and load ground.

Product Summary

Rds(on)	130mΩ max.
Vclamp	39V
I Limit	7A
Open load	3V / 0.22A

Packages

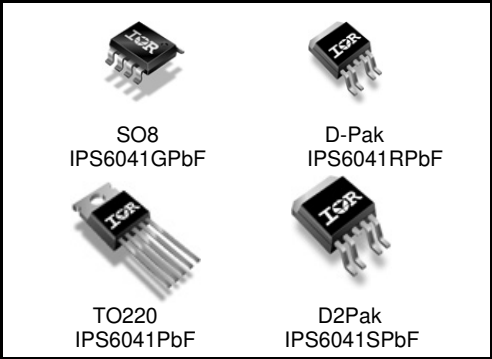

Typical Connection

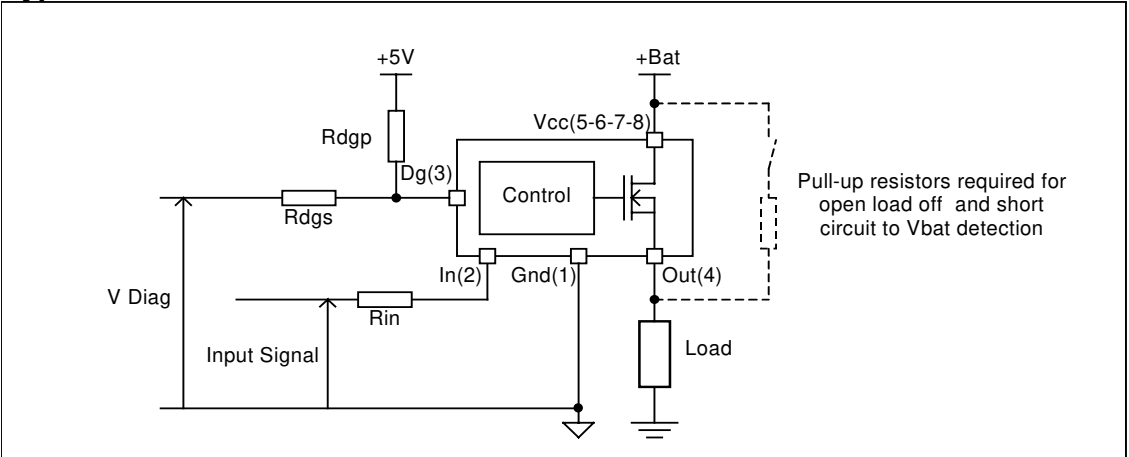

Absolute Maximum Ratings

Absolute maximum ratings indicate sustained limits beyond which damage to the device may occur. All voltage parameters are referenced to Ground lead. (Tambient=25°C unless otherwise specified).

Symbol	Parameter	Min.	Max.	Units
Vout	Maximum output voltage	Vcc-35	Vcc+0.3	V
Voffset	Maximum logic ground to load ground offset	Vcc-35	Vcc+0.3	
Vin	Maximum input voltage	-0.3	5.5	
Vcc max.	Maximum Vcc voltage	—	36	
Vcc cont.	Maximum continuous Vcc voltage	—	28	
Iin max.	Maximum IN current	-3	10	mA
I _{dg} max.	Maximum diagnostic output current	-3	10	
V _{dg}	Maximum diagnostic output voltage	-0.3	5.5	V
Pd	Maximum power dissipation (internally limited by thermal protection) R _{th} =100°C/W IPS6041G	—	1.25	W
	R _{th} =50°C/W IPS6041R 1" sqrt. footprint	—	2.5	
ESD	Electrostatic discharge voltage (Human body) C=100pF, R=1500Ω Between In and Vcc	—	1500	V
	Other combinations	—	4000	
	Electrostatic discharge voltage (Machine Model) C=200pF, R=0Ω, L=10μH Between In and Vcc	—	100	
	Other combinations	—	500	
T _j max.	Max. storage & operating temperature junction temperature	-40	150	°C
T _{soldering}	Soldering temperature (10 seconds)	—	300	°C

Thermal Characteristics

Symbol	Parameter	Typ.	Max.	Units
R _{th1}	Thermal resistance junction to ambient IPS6041G	100	—	°C/W
R _{th1}	Thermal resistance junction to ambient IPS6041R D-Pak std. footprint	70	—	
R _{th2}	Thermal resistance junction to ambient IPS6041R D-Pak 1" sqrt. footprint	50	—	
R _{th3}	Thermal resistance junction to case IPS6041(R)(S) D-Pak/D2pak/TO220	6	—	
R _{th1}	Thermal resistance junction to ambient IPS6041(S) D2Pak/TO220 std. footprint	60	—	
R _{th2}	Thermal resistance junction to ambient IPS6041S D2Pak 1" sqrt. footprint	40	—	

Recommended Operating Conditions

These values are given for a quick design. For operation outside these conditions, please consult the application notes.

Symbol	Parameter	Min.	Max.	Units
V _{IH}	High level input voltage	4	5.5	
V _{IL}	Low level input voltage	0	0.9	
I _{out}	Continuous drain current, T _{ambient} =85°C, T _j =125°C, V _{in} =5V R _{th} =100°C/W IPS6041G R _{th} =50°C/W IPS6041R 1" sqrt. footprint	—	1.6 2.3	A
R _{in}	Recommended resistor in series with IN pin	4	10	
R _{dgs}	Recommended resistor in series with DG pin for reverse battery protection	4	20	kΩ
R _{dg_p}	Recommended pull-up resistor for DG	4	20	
R _{ol}	Recommended pull-up resistor for open load detection	5	100	
F max.	Max. switching frequency	—	3.5	kHz

Static Electrical Characteristics

$T_j=25^{\circ}\text{C}$, $V_{cc}=14\text{V}$ (unless otherwise specified)

Symbol	Parameter	Min.	Typ.	Max.	Units	Test Conditions
Rds(on)	ON state resistance $T_j=25^{\circ}\text{C}$	—	110	130	m Ω	$V_{in}=5\text{V}$, $I_{out}=2.5\text{A}$
	ON state resistance $T_j=150^{\circ}\text{C}$	—	190	230		$V_{in}=5\text{V}$, $I_{out}=2.5\text{A}$
	ON state resistance $T_j=25^{\circ}\text{C}$, $V_{cc}=6\text{V}$	—	125	155		$V_{in}=5\text{V}$, $I_{out}=1.5\text{A}$
	ON state resistance during reverse battery	—	140	180		$V_{cc}\text{-Gnd}=14\text{V}$
Vcc op.	Operating voltage range	6	—	28	V	
V clamp 1	Vcc to Out clamp voltage 1	37	39	—		$I_{out}=20\text{mA}$
V clamp 2	Vcc to Out clamp voltage 2	—	40	42		$I_{out}=2.5\text{A}$ (see Fig. 1)
Icc Off	Supply current when Off	—	4	9	μA	$V_{in}=0\text{V}$, $V_{out}=0\text{V}$
Icc On	Supply current when On	—	2.2	5	mA	$V_{in}=5\text{V}$
Vih	Input high threshold voltage	—	2.5	2.9	V	
Vil	Input low threshold voltage	1.5	2	—		
In hyst.	Input hysteresis	0.2	0.5	1		
Iin On	Input current when device is On	—	45	100		μA
I _{dg}	Dg leakage current	—	0.1	10		$V_{dg}=5\text{V}$
V _{dg}	Low level DG voltage	—	0.25	0.4	V	$I_{dg}=1.6\text{mA}$

Switching Electrical Characteristics

$V_{cc}=14\text{V}$, Resistive load= 6Ω , $V_{in}=5\text{V}$, $T_j=25^{\circ}\text{C}$

Symbol	Parameter	Min.	Typ.	Max.	Units	Test Conditions
T _{don}	Turn-on delay time	—	5	15	μs	see Fig. 3
Tr1	Rise time to $V_{out}=V_{cc}-5\text{V}$	—	3	10		
Tr2	Rise time to $V_{out}=0.9 \times V_{cc}$	—	4	20		
dV/dt (On)	Turn On dV/dt	—	2.5	5	V/ μs	
E _{On}	Turn On energy	—	100	—	μJ	
T _{doff}	Turn-off delay time	—	10	20	μs	
T _f	Fall time to $V_{out}=0.1 \times V_{cc}$	—	3	10		
dV/dt (Off)	Turn Off dV/dt	—	6.5	20	V/ μs	
E _{Off}	Turn Off energy	—	50	—	μJ	

Protection Characteristics

Symbol	Parameter	Min.	Typ.	Max.	Units	Test Conditions
Ilim	Internal current limit	4	7	10	A	Vout=0V
Tsd+	Over temperature high threshold	150(1)	165	—	°C	See fig. 2
Tsd-	Over temperature low threshold	—	158	—		
Vsc	Short-circuit detection voltage(2)	2	3	4	V	
UV		—	5	5.9		
UV hyst.		0.25	—	1.6		
VOL Off	Open load detection threshold	2	3	4		
IOL On	Open load detection threshold	0.05	0.15	0.22	A	

(1) Guaranteed by design

(2) Reference to Vcc

True Table

Operating Conditions	IN	OUT	DG
Normal	H	H	H
Normal	L	L	H
Open Load	H	H	L
Open Load (3)	L	H	L
Short circuit to Gnd	H	L	L
Short circuit to Gnd	L	L	H
Short circuit to Vcc	H	H	L (4)
Short circuit to Vcc (5)	L	H	L
Over-temperature	H	L	L
Over-temperature	L	L	H

(3) With a pull-up resistor connected between the output and Vcc.

(4) Vds lower than 10mV.

(5) Without a pull-up resistor connected between the output and Vcc.

Lead Assignments

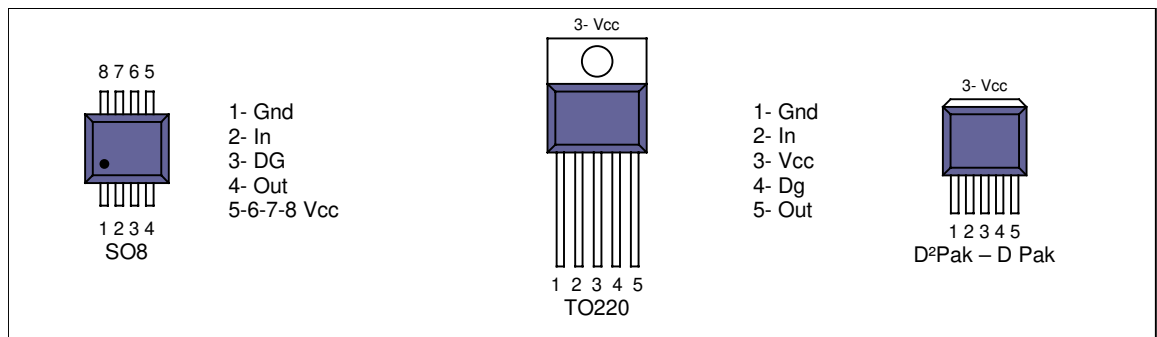

Functional Block Diagram

All values are typical

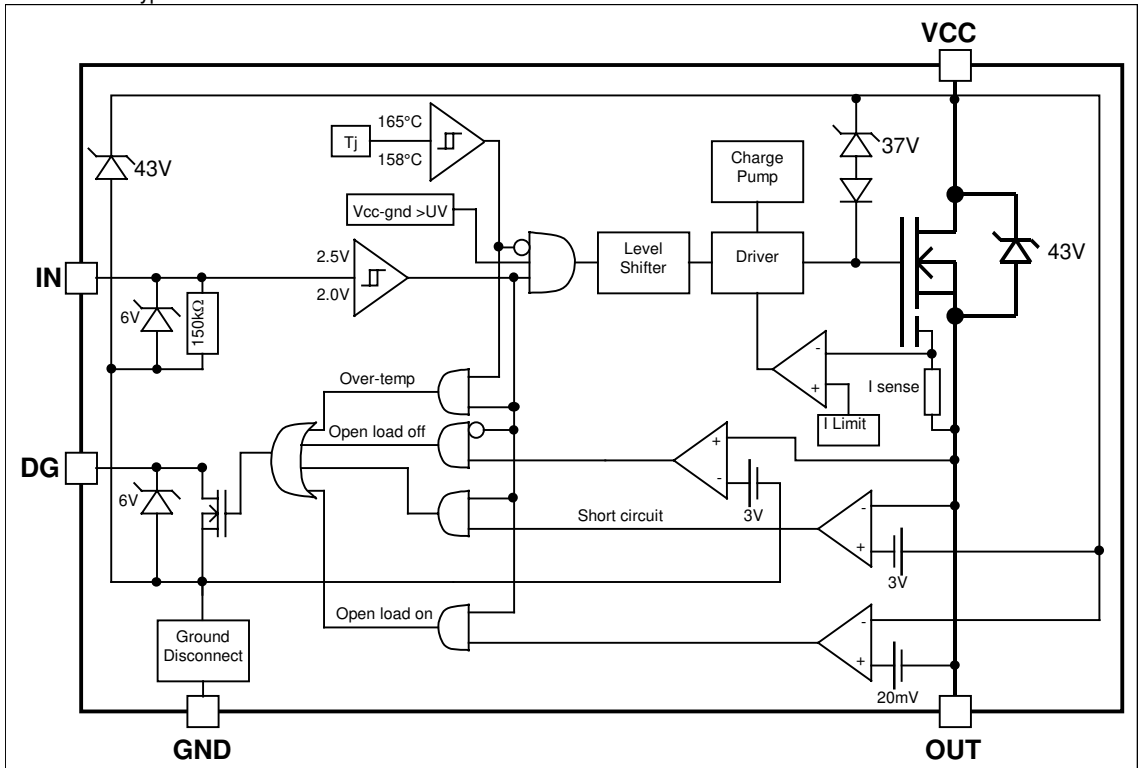

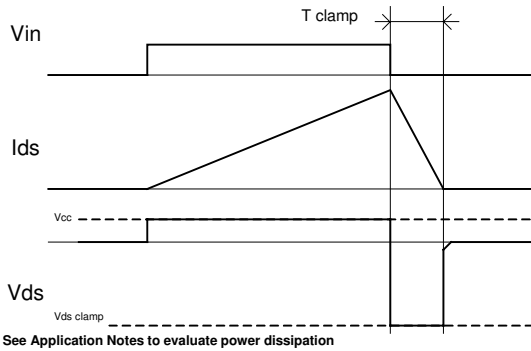

Figure 1 – Active clamp waveforms

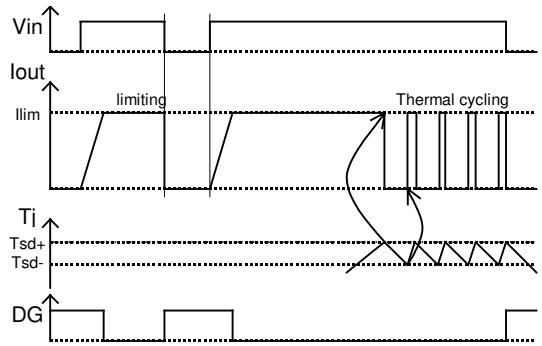

Figure 2 – Protection timing diagram

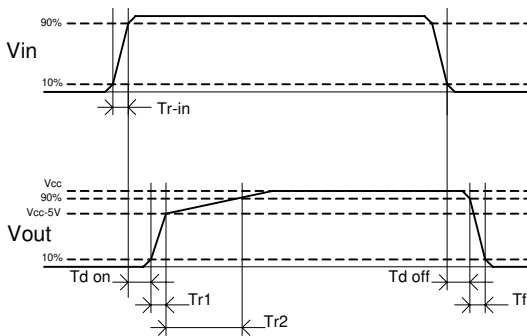

Figure 3 – Switching times definitions

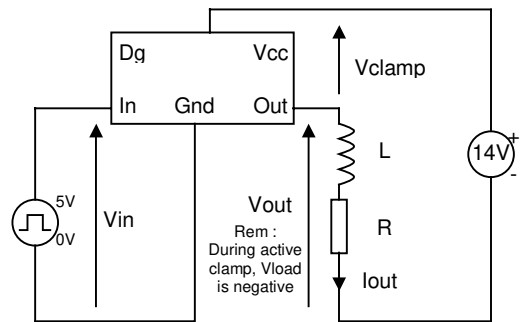

Figure 4 – Active clamp test circuit

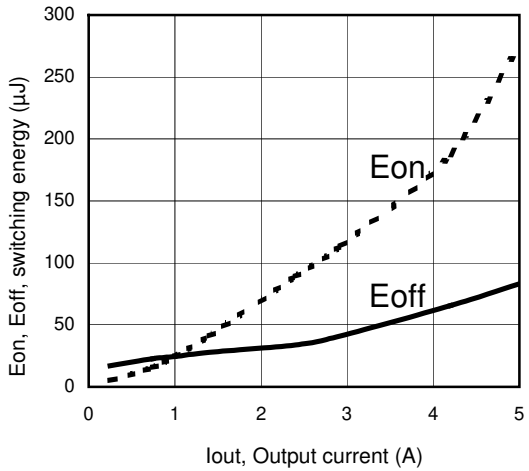

Figure 5 – Switching energy (μJ) Vs Output current (A)

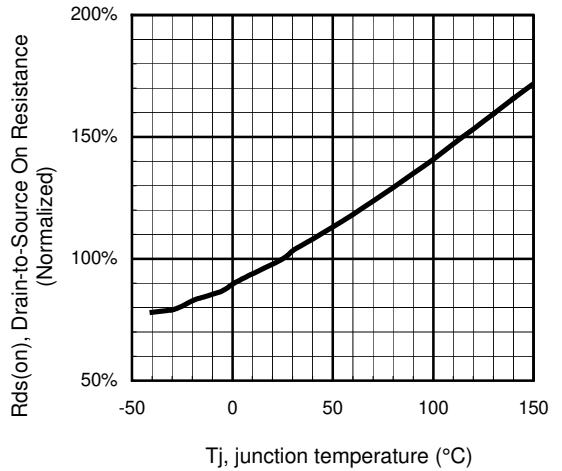

Figure 6 - Normalized R_{ds(on)} (%) Vs T_j (°C)

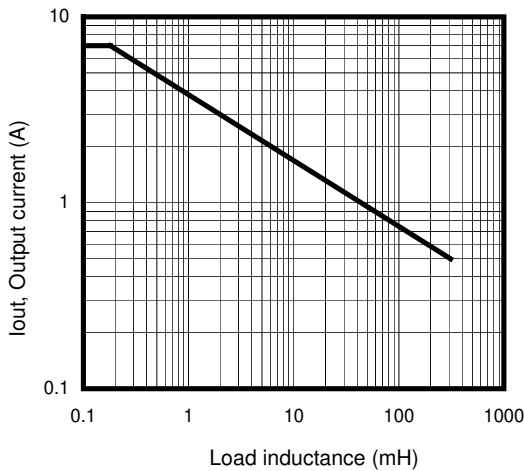

Figure 7 – Max. Output current (A) Vs Load inductance (mH)

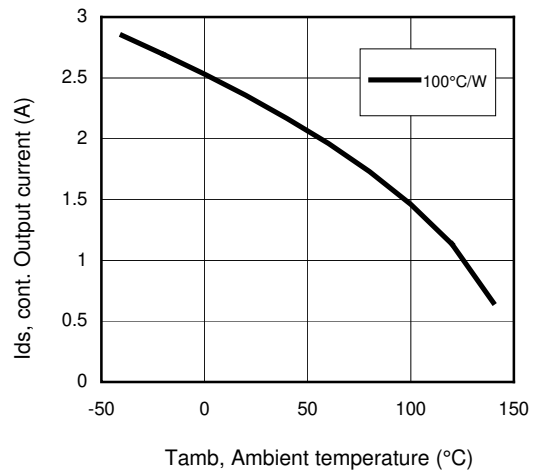

Figure 8 – Max. output current (A) Vs Ambient temperature (°C)

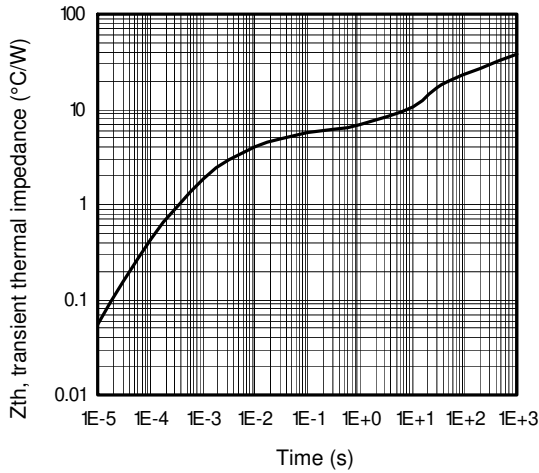

Figure 9 – Transient thermal impedance ($^{\circ}\text{C}/\text{W}$) Vs time (s)

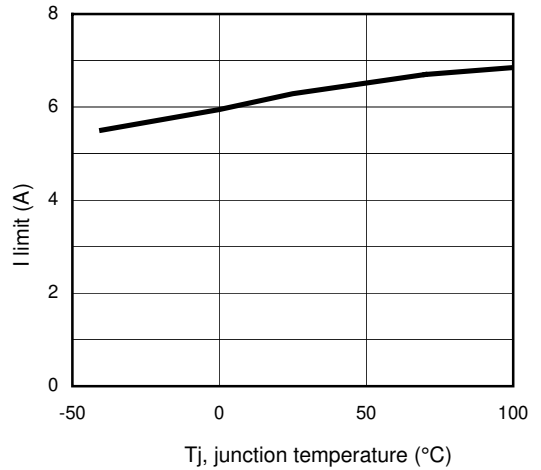

Figure 10 – I limit (A) Vs junction temperature ($^{\circ}\text{C}$)

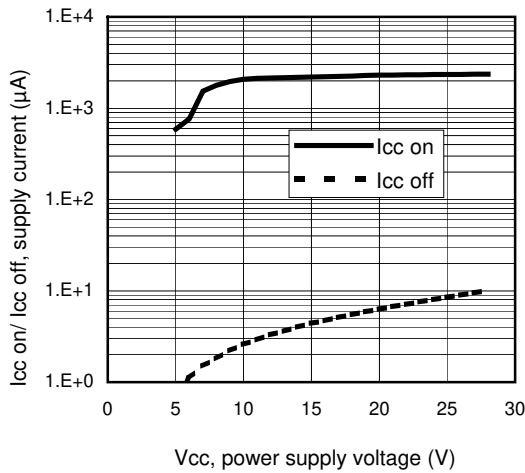

Figure 11 – $I_{cc\ on}/ I_{cc\ off}$ (μA) Vs V_{cc} (V)

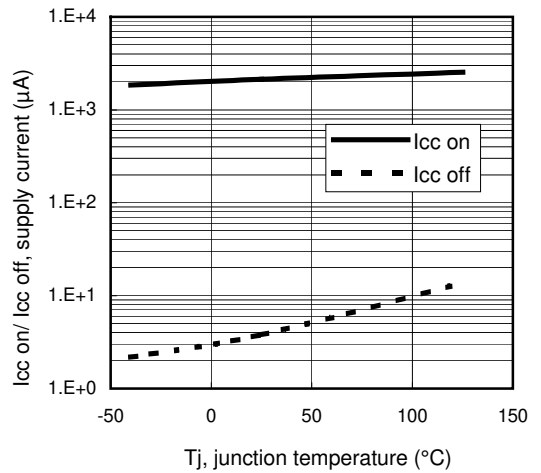
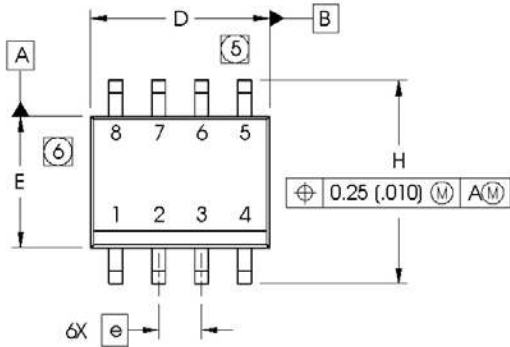

Figure 12 – $I_{cc\ on}/ I_{cc\ off}$ (μA) Vs T_j ($^{\circ}\text{C}$)

Case Outline – SO8 - Automotive Q100 PbF MSL2 qualified

Dimensions are shown in millimeters (inches)



DIM	INCHES		MILLIMETERS	
	MIN	MAX	MIN	MAX
A	.0532	.0688	1.35	1.75
A1	.0040	.0098	0.10	0.25
b	.013	.020	0.33	0.51
c	.0075	.0098	0.19	0.25
D	.189	.1968	4.80	5.00
E	.1497	.1574	3.80	4.00
e	.050 BASIC		1.27 BASIC	
e1	.025 BASIC		0.635 BASIC	
H	.2284	.2440	5.80	6.20
K	.0099	.0196	0.25	0.50
L	.016	.050	0.40	1.27
y	0°	8°	0°	8°

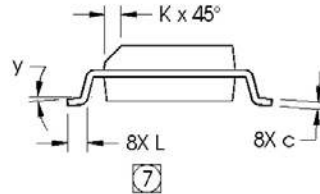
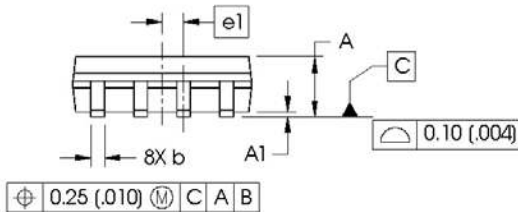

NOTES:

1. DIMENSIONING & TOLERANCING PER ASME Y14.5M-1994.
2. CONTROLLING DIMENSION: MILLIMETER
3. DIMENSIONS ARE SHOWN IN MILLIMETERS (INCHES).
4. OUTLINE CONFORMS TO JEDEC OUTLINE MS-012AA.
5. DIMENSION DOES NOT INCLUDE MOLD PROTRUSIONS. MOLD PROTRUSIONS NOT TO EXCEED 0.15 (.006).
6. DIMENSION DOES NOT INCLUDE MOLD PROTRUSIONS. MOLD PROTRUSIONS NOT TO EXCEED 0.25 (.010).
7. DIMENSION IS THE LENGTH OF LEAD FOR SOLDERING TO A SUBSTRATE.

FOOTPRINT

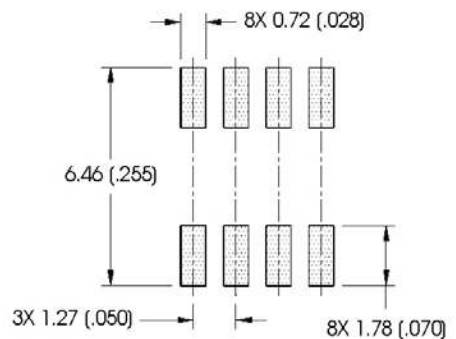

Tape & Reel SO8

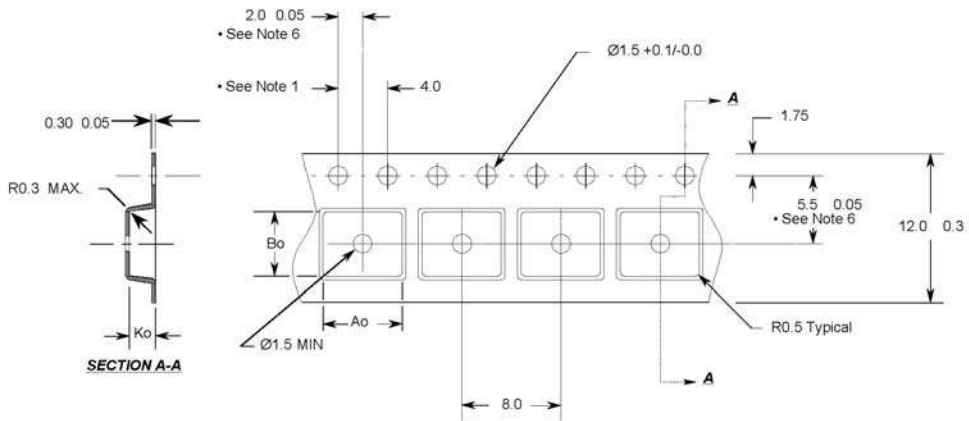

Notes:

1. 10 sprocket hole pitch cumulative tolerance 0.2
2. Camber not to exceed 1mm in 100mm
3. Material: Black Conductive Advantek Polystyrene
4. Ao and Bo measured on a plane 0.3mm above the bottom of the pocket
5. Ko measured from a plane on the inside bottom of the pocket to the top surface of the carrier.
6. Pocket position relative to sprocket hole measured as true position of pocket, not pocket hole.

Ao = 6.4 mm
 Bo = 5.2 mm
 Ko = 2.1 mm

- All Dimensions in Millimeters -

Case Outline - TO220 (5 lead) - Automotive Q100 PbF qualified

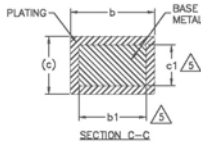
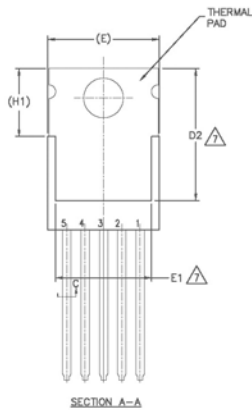
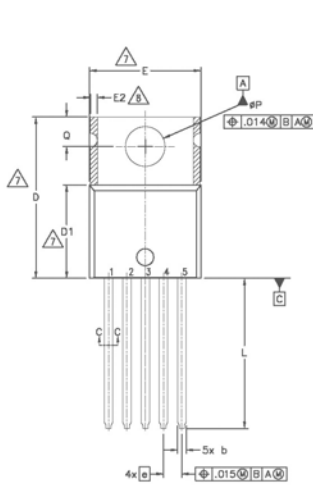

SYMBOL	DIMENSIONS				NOTES	
	MILLIMETERS		INCHES			
	MIN.	MAX.	MIN.	MAX.		
A	3.56	4.83	.140	.190	5	
A1	0.51	1.40	.020	.055		
A2	2.03	2.92	.080	.115		
b	0.64	0.89	.025	.035		
b1	0.64	0.84	.025	.033		
c	0.36	0.61	.014	.024		
c1	0.36	0.56	.014	.022		
D	14.22	16.51	.560	.650		4
D1	8.38	9.02	.330	.355		7
D2	11.68	12.88	.460	.507		
E	9.65	10.67	.380	.420	4,7	
E1	6.86	8.89	.270	.350	7	
E2	-	0.76	-	.030	8	
e	1.70 BSC		.067 BSC		7,8	
H1	5.84	6.86	.230	.270		
L	12.70	14.73	.500	.580		
φP	3.53	3.73	.139	.147		
Q	2.54	3.05	.100	.120		

NOTES:

- 1.- DIMENSIONING AND TOLERANCING AS PER ASME Y14.5 M-1994.
- 2.- DIMENSIONS ARE SHOWN IN INCHES [MILLIMETERS]
- 3.- LEAD DIMENSION AND FINISH UNCONTROLLED IN L1.
- 4.- DIMENSION D, D1 & E DO NOT INCLUDE MOLD FLASH. MOLD FLASH SHALL NOT EXCEED .005" (0.127) PER SIDE. THESE DIMENSIONS ARE MEASURED AT THE OUTERMOST EXTREMES OF THE PLASTIC BODY.
- 5.- DIMENSION b1 & c1 APPLY TO BASE METAL ONLY.
- 6.- CONTROLLING DIMENSION : INCHES.
- 7.- THERMAL PAD CONTOUR OPTIONAL WITHIN DIMENSIONS E,H1,D2 & E1
- 8.- DIMENSION E2 X H1 DEFINE A ZONE WHERE STAMPING AND SINGULATION IRREGULARITIES ARE ALLOWED.
- 9.- OUTLINE CONFORMS TO JEDEC TO-220, EXCEPT A2 (max.) AND D2 (min.) WHERE DIMENSIONS ARE DERIVED FROM THE ACTUAL PACKAGE OUTLINE.
- 10.- LEADS AND DRAIN ARE PLATED WITH 100% Sn

Case Outline 5 Lead - D2PAK - Automotive Q100 PbF MSL1 qualified

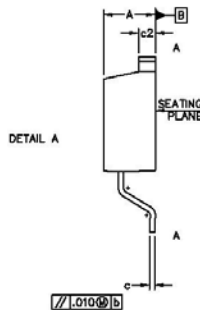
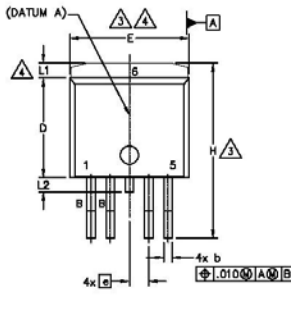
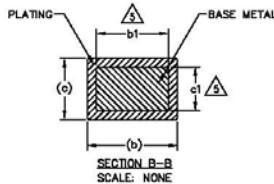
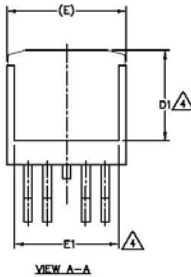
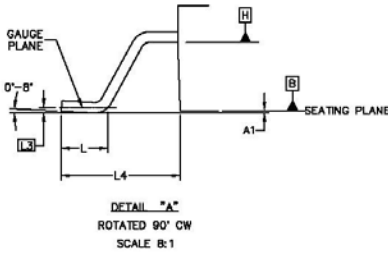

NOTES:

1. DIMENSIONING AND TOLERANCING AS PER ASME Y14.5M-1994
2. DIMENSIONS ARE SHOWN IN MILLIMETERS [INCHES]
3. DIMENSION D & E DO NOT INCLUDE MOLD FLASH. MOLD FLASH SHALL NOT EXCEED 0.127 [0.005"] PER SIDE. THESE DIMENSIONS ARE MEASURED AT THE OUTMOST EXTREMES OF THE PLASTIC BODY AT DATUM H.
4. THERMAL PAD CONTOUR OPTIONAL WITHIN DIMENSION E, L1, D1 & E1.
5. DIMENSION b1 AND c1 APPLY TO BASE METAL ONLY.
6. DATUM A & B TO BE DETERMINED AT DATUM PLANE H.
7. CONTROLLING DIMENSION: INCH.
8. OUTLINE CONFORMS TO JEDEC OUTLINE TO-263BA.
9. LEADS AND DRAIN ARE PLATED : 100% Sn

SYM- BO- L	DIMENSIONS				NOTES
	MILLIMETERS		INCHES		
	MIN.	MAX.	MIN.	MAX.	
A	4.06	4.83	.160	.190	
A1	-	0.254	-	.010	
b	0.51	0.99	.020	.039	4
b1	0.51	0.89	.020	.035	
c	0.38	0.74	.015	.029	
c1	0.38	0.58	.015	.023	4
c2	1.14	1.65	.045	.065	
D	8.38	9.65	.330	.380	3
D1	6.86	-	.270	-	
E	9.65	10.87	.380	.420	3
E1	6.22	-	.245	-	
e	1.70	BSC	.067	BSC	
H	14.61	15.88	.575	.625	
L	1.78	2.79	.070	.110	
L1	-	1.68	-	.066	
L2	-	1.78	-	.070	
L3	0.25	BSC	.010	BSC	
L4	4.78	5.28	.188	.208	

Tape & Reel 5 Lead - D2PAK

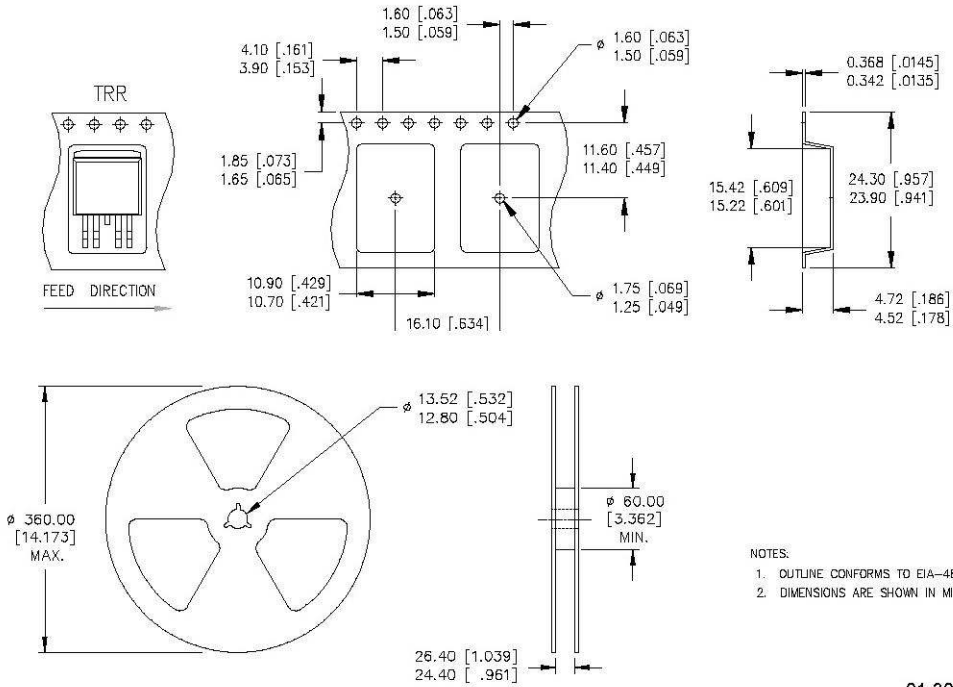

01-3071 00 / 01-3072 00

Case Outline 5 Lead – DPAK - Automotive Q100 PbF MSL1 qualified

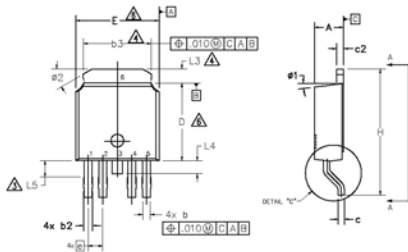
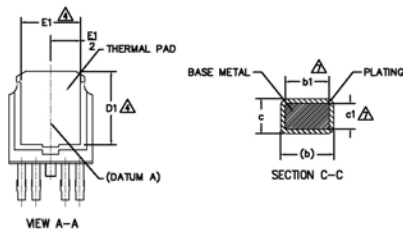
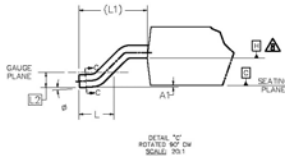

SYMBOLOL	DIMENSIONS				NOTES
	MILLIMETERS		INCHES		
	MIN.	MAX.	MIN.	MAX.	
A	2.18	2.39	.086	.094	
A1	—	0.13	—	.005	
b	0.51	0.89	.020	.035	
b1	.051	0.84	.020	.033	2
b3	4.95	5.46	.195	.215	2
c	0.46	0.61	.018	.024	
c1	0.41	0.56	.016	.022	2
c2	0.46	0.89	.018	.035	
D	5.97	6.22	.235	.245	3
D1	5.21	—	.205	—	
E	6.35	6.73	.250	.265	3
E1	4.32	—	.170	—	
e	1.14 BSC		.045 BSC		
H	9.40	10.41	.370	.410	
L	1.40	1.78	.055	.070	
L1	2.74 BSC		.108 REF.		
L2	0.51 BSC		.020 BSC		
L3	0.89	1.27	.035	.050	
L4	—	1.02	—	.040	
L5	1.14	1.52	.045	.060	
φ	0"	10"	0"	10"	
φ1	0"	15"	0"	15"	
φ2	28"	32"	28"	32"	

NOTES:

- 1.- DIMENSIONING AND TOLERANCING AS PER ASME Y14.5M-1994
- 2.- DIMENSIONS ARE SHOWN IN INCHES [MILLIMETERS].
- 3.- LEAD DIMENSION UNCONTROLLED IN L5.
- 4.- DIMENSION D1, E1, L3 & b3 ESTABLISH A MINIMUM MOUNTING SURFACE FOR THERMAL PAD.
- 5.- SECTION C-C DIMENSIONS APPLY TO THE FLAT SECTION OF THE LEAD BETWEEN .005 AND 0.10 [0.13 AND 0.25] FROM THE LEAD TIP.
- 6.- DIMENSION D & E DO NOT INCLUDE MOLD FLASH. MOLD FLASH SHALL NOT EXCEED .005 [0.13] PER SIDE. THESE DIMENSIONS ARE MEASURED AT THE OUTMOST EXTREMES OF THE PLASTIC BODY.
- 7.- DIMENSION b1 & c1 APPLIED TO BASE METAL ONLY.
- 8.- DATUM A & B TO BE DETERMINED AT DATUM PLANE H.
- 9.- OUTLINE CONFORMS TO JEDEC OUTLINE TO-252.
10. LEADS AND DRAIN ARE PLATED WITH 100% Sn

Tape & Reel 5 Lead – DPAK

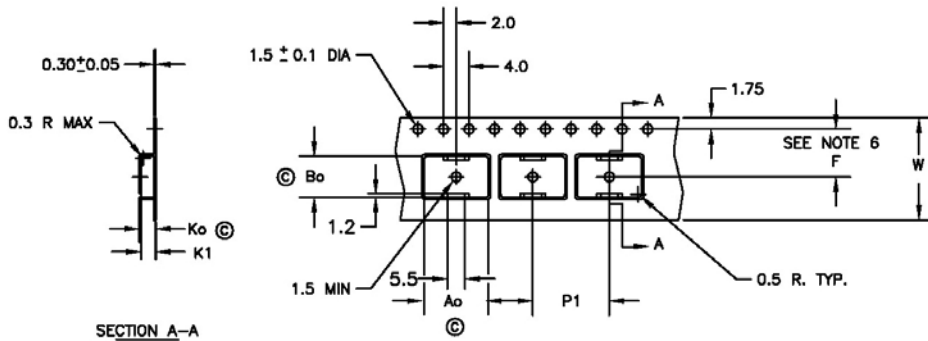

SECTION A-A

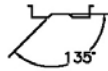

$A_o = 10.5 \text{ mm}$
 $B_o = 7.0 \text{ mm}$
 $K_o = 2.8 \text{ mm}$
 $K_1 = 2.4 \text{ mm}$
 $F = 7.5 \text{ mm}$
 $P_1 = 12.0 \text{ mm}$
 $W = 16.0 \pm .3 \text{ mm}$

NOTES:

1. 10 SPROCKET HOLE PUNCH CUMULATIVE TOLERANCE ± 0.02
2. CAMBER NOT TO EXCEED 1mm IN 100mm
3. MATERIAL: CONDUCTIVE BLACK POLYSTYRENE
4. A_o AND B_o MEASURED ON A PLANE 0.3mm ABOVE THE BOTTOM OF THE POCKET
5. K_o MEASURED FROM A PLANE ON THE INSIDE BOTTOM OF THE POCKET TO THE TOP SURFACE OF THE CARRIER
6. POCKET POSITION RELATIVE TO THE SPROCKET HOLE MEASURED AS TRUE POSITION OF POCKET, NOT POCKET HOLE
7. VENDOR: (OPTIONAL)
8. MUST ALSO MEET REQUIREMENTS OF EIA STANDARD #EIA-481A, TAPING OF SURFACE-MOUNT COMPONENTS FOR AUTOMATIC PLACEMENT.
9. TOLERANCE TO BE MANUFACTURER STANDARD
10. SURFACE RESISTIVITY OF MOLDED MATL: MUST MEASURE LESS THAN OR EQUAL TO 10^8 OHMS PER SQUARE. MEASURED IN ACCORDANCE TO PROCEDURE GIVEN IN ASTM D-257 & ASTM D-991 (REF. C-9000 SPEC.)
11. TOTAL LENGTH PER REEL MUST BE 79 METERS
12. © CRITICAL DIMENSION

Note: For the most current drawings please refer to the IR website at:
<http://www.irf.com/package/>