

MATERIAL NUMBER	ALTERNATE NUMBER	"S"	WIRE RANGE	COLOR	PACKAGING
190570013	A-522-10	.198/5.02	22-18 AWG	RED	LOOSE PIECE
190570015	A-522-14	.265/6.73	22-18 AWG	RED	
190570017	A-522-56	.328/8.33	22-18 AWG	RED	
190570014	A-522-10T	.198/5.02	22-18 AWG	RED	TAPE
190570016	A-522-14T	.265/6.73	22-18 AWG	RED	
190570018	A-522-56T	.328/8.33	22-18 AWG	RED	

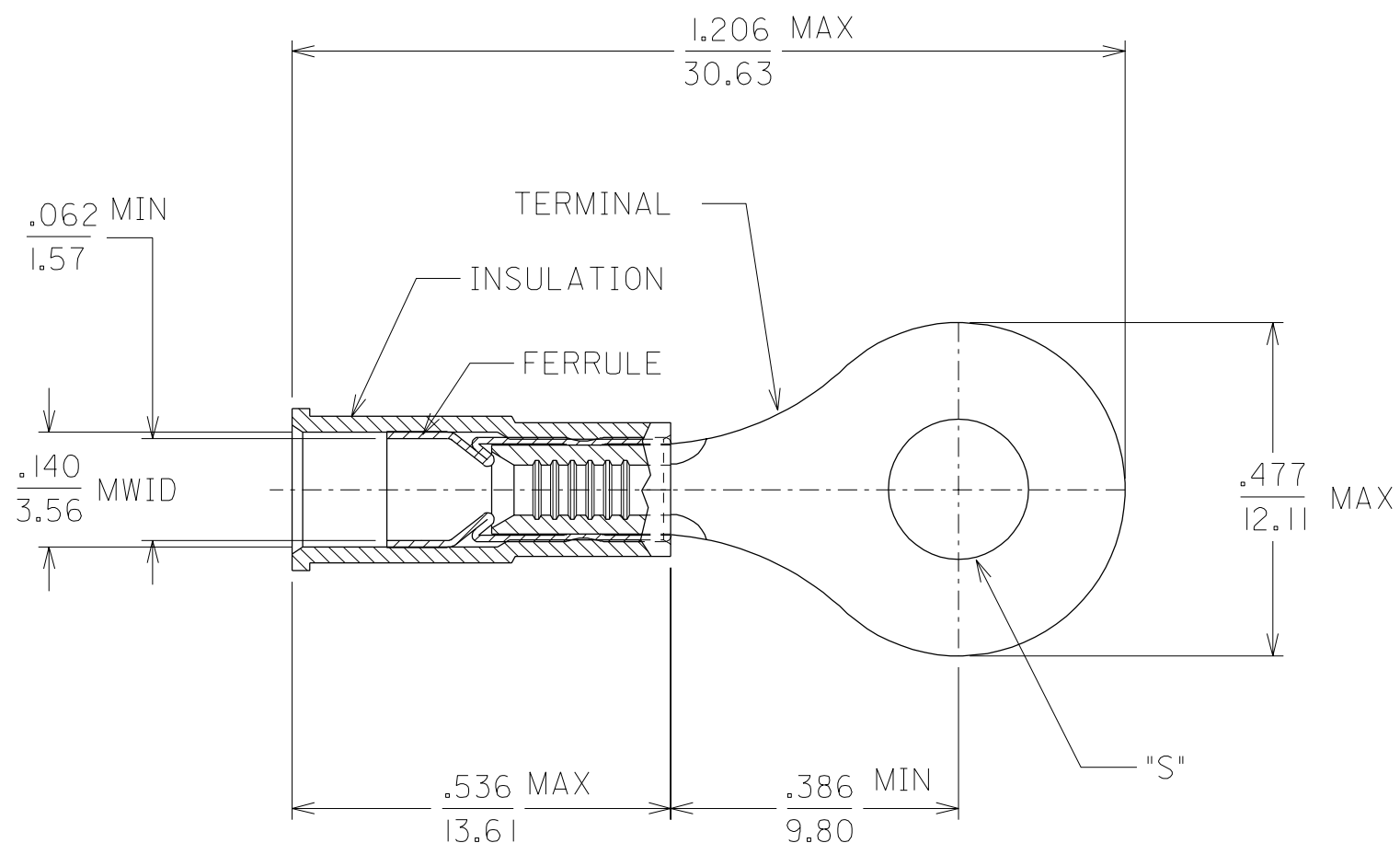
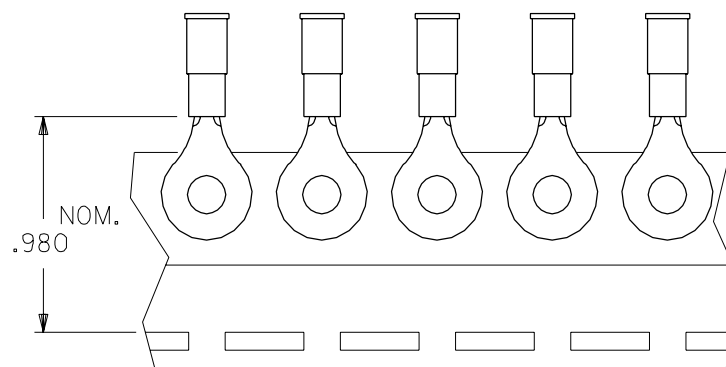

A	NEW CUST. DWG. ETC2001-0288 01/03/23 EDB
LTR.	REVISIONS

CUSTOMER DRAWING

- MATERIAL: TERMINAL: COPPER  
.028/.711 THICK.  
FUNNEL FERRULE: BRASS  
PLATING: ELECTRO TIN  
INSULATION: NYLON 6/6  
COLOR: SEE CHART
- MWID = MAXIMUM WIRE INSULATION DIAMETER
- ALL DIMENSIONS = INCHES / MM

DIMENSIONS SHOWN (METRIC) INCH		REVISE ONLY ON CAD SYSTEM																			
UNLESS OTHERWISE SPECIFIED TOLERANCES: ANGULAR ± 1/2°		TITLE RING TONGUE TERMINAL AVIKRIMP 500 SERIES																			
<table border="1"> <thead> <tr> <th></th> <th>INCH</th> <th>METRIC</th> </tr> </thead> <tbody> <tr> <td>3 PLACE</td> <td>± .005</td> <td>± ---</td> </tr> <tr> <td>2 PLACE</td> <td>± .01</td> <td>± 0.13</td> </tr> <tr> <td>1 PLACE</td> <td>± ---</td> <td>± 0.25</td> </tr> </tbody> </table>			INCH	METRIC	3 PLACE	± .005	± ---	2 PLACE	± .01	± 0.13	1 PLACE	± ---	± 0.25	<table border="1"> <tr> <td> ETC INC.</td> <td>SHEET NO.</td> <td>DATE</td> </tr> <tr> <td>PINELLAS PARK, FLA. 33781 U.S.A.</td> <td>1 OF 1</td> <td>01/03/23</td> </tr> </table>		ETC INC.	SHEET NO.	DATE	PINELLAS PARK, FLA. 33781 U.S.A.	1 OF 1	01/03/23
	INCH	METRIC																			
3 PLACE	± .005	± ---																			
2 PLACE	± .01	± 0.13																			
1 PLACE	± ---	± 0.25																			
ETC INC.	SHEET NO.	DATE																			
PINELLAS PARK, FLA. 33781 U.S.A.	1 OF 1	01/03/23																			
DRAFT WHERE APPLICABLE MUST REMAIN WITHIN DIMENSIONS		PART NO. <b>SEE TABLE</b>																			
<table border="1"> <tr> <td>DRWG. BY EDB</td> <td>CHK'D. BY HEB</td> </tr> <tr> <td>APP'D. BY RWD</td> <td>SCALE NO: NE</td> </tr> </table>		DRWG. BY EDB	CHK'D. BY HEB	APP'D. BY RWD	SCALE NO: NE	<table border="1"> <tr> <td>FILE NAME SD19057003 DGN</td> <td>THIS DRAWING CONTAINS INFORMATION THAT IS PROPRIETARY TO MOLEX-ETC INC. AND SHOULD NOT BE USED WITHOUT WRITTEN PERMISSION.</td> <td>DIV. ET</td> <td>SIZE B</td> </tr> </table>		FILE NAME SD19057003 DGN	THIS DRAWING CONTAINS INFORMATION THAT IS PROPRIETARY TO MOLEX-ETC INC. AND SHOULD NOT BE USED WITHOUT WRITTEN PERMISSION.	DIV. ET	SIZE B										
DRWG. BY EDB	CHK'D. BY HEB																				
APP'D. BY RWD	SCALE NO: NE																				
FILE NAME SD19057003 DGN	THIS DRAWING CONTAINS INFORMATION THAT IS PROPRIETARY TO MOLEX-ETC INC. AND SHOULD NOT BE USED WITHOUT WRITTEN PERMISSION.	DIV. ET	SIZE B																		
		DRWG. NO. <b>SD-19057-003</b>																			