

OV9733 720p HD product brief



available in
a lead-free
package

Low-Power and Compact HD CameraChip™ Sensor with RGB-IR Enables Battery-Powered Smart-Home and Security Applications

OmniVision's OV9733 is a low-power and ultra-compact CameraChip™ sensor that brings 720p high definition (HD) video to mainstream security systems and wireless battery-powered smart home cameras.

The OV9733 is equipped with RGB-IR pixels that can replace traditional mechanical IR cut filter, thus simplifying the system design and enabling the sensor to capture high quality infrared images and video, even from long ranges.

The OV9733 CameraChip sensor utilizes OmniPixel3-HS™ high sensitivity 3.0 μm pixel technology to bring industry-leading scene reproduction

to a wide range of security and lifestyle camera applications that operate in extremely high- and low-light conditions. The sensor's narrow 9-degree chief ray angle (CRA) supports consumer-grade optical lens systems and reduces image artifacts for enhanced performance.

When operating in low-power mode, the 1/4-inch OV9733 requires just 115 mW to capture 720p HD video at 30 frames per second.

Find out more at www.ovt.com.



Applications

- IP Cameras
- Life Style Cameras
- Surveillance
- Motion Cameras

Product Features

- RGB-IR color filter
- support for image sizes: full size (1280x720), VGA (640x480), 2x2 RGB-IR binning (640x360)
- support for output formats: 10-bit RAW RGB-IR output with 1-lane MIPI and DVP
- on-chip phase lock loop (PLL)
- programmable controls for frame rate, mirror and flip, gain/exposure, and windowing
- support for horizontal and vertical sub-sampling
- low power mode (LPM) function
- capable of maintaining register values at software power down
- standard SCCB interface
- GPIO tri-state configurability and programmable polarity
- FSIN
- image quality control: automatic black level calibration (ABLC)

OV9733



Ordering Information

- OV09733-H35A (RGB-IR, lead-free, 35-pin CSP5)

Product Specifications

- active array size: 1280 x 720
- lens chief ray angle: 9°
- power supply:
 - core: 1.7 - 1.9V (1.8V normal)
 - analog: 3.1 - 3.45V (3.3V normal)
 - I/O: 1.7 - 1.9V (1.8V normal)
- temperature range:
 - operating: -30°C to +70°C junction temperature
 - stable image: 0°C to +50°C junction temperature
- output formats: 10-bit RAW RGB-IR
- lens size: 1/4"
- input clock frequency: 6 - 27 MHz
- maximum image transfer rate: 30 fps
- scan mode: progressive
- shutter: rolling shutter
- pixel size: 3 μm x 3 μm
- image area: 3888 μm x 2208 μm
- package dimensions: 4704 μm x 2994 μm

Functional Block Diagram

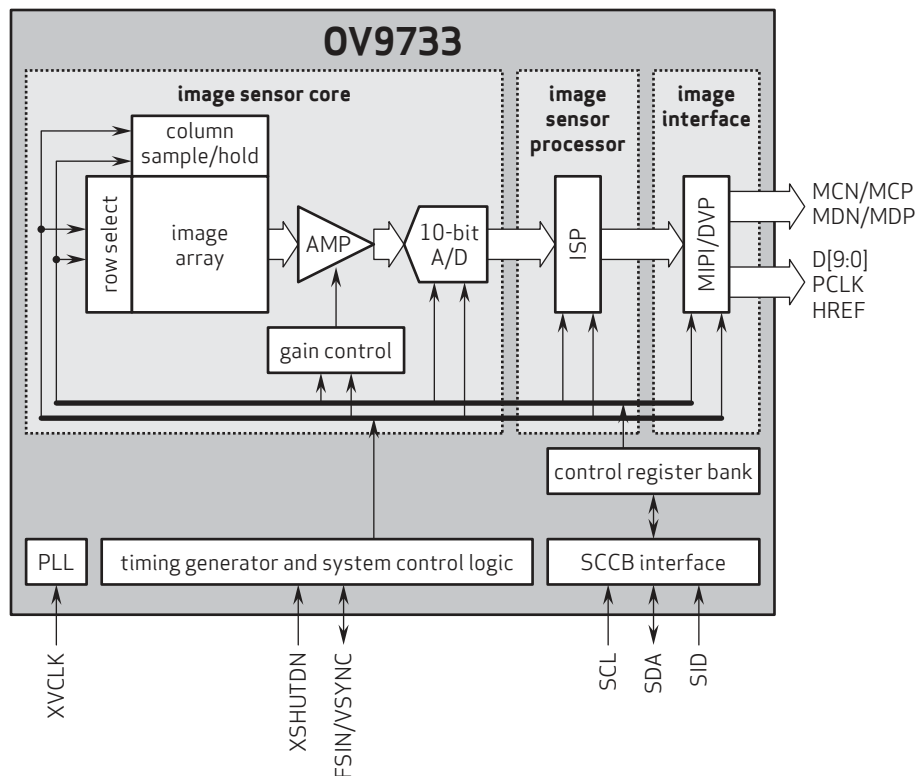

4275 Burton Drive
Santa Clara, CA 95054
USA

Tel: +1 408 567 3000
Fax: +1 408 567 3001
www.ovt.com

OmniVision reserves the right to make changes to their products or to discontinue any product or service without further notice. OmniVision is a registered trademark of OmniVision Technologies, Inc. The OmniVision logo and PureCel are trademarks of OmniVision Technologies, Inc. All other trademarks are the property of their respective owners.



OmniVision