



# 5V or Adjustable, Low-Voltage, Step-Up DC-DC Controller

MAX608

## General Description

The MAX608 low-voltage step-up controller operates from a 1.8V to 16.5V input voltage range. Pulse-frequency-modulation (PFM) control provides high efficiency at heavy loads, while using only 85µA (typical) when operating with no load. In addition, a logic-controlled shutdown mode reduces supply current to 2µA typical. The output voltage is factory-set at 5V or can be adjusted from 3V to 16.5V with an external resistor divider.

The MAX608 is ideal for two- and three-cell battery-powered systems. An operating frequency of up to 300kHz allows use with small surface-mount components.

The MAX608 operates in "bootstrapped" mode only (with the chip supply, OUT, connected to the DC-DC output). For a 12V output without external resistors, or for nonbootstrapped applications (chip supply connected to input voltage), refer to the pin-compatible MAX1771. The MAX608 is available in 8-pin DIP and SO packages.

## Features

- ◆ 1.8V to 16.5V Input Range
- ◆ 85% Efficiency for 30mA to 1.5A Load Currents
- ◆ Up to 10W Output Power
- ◆ 110µA Max Supply Current
- ◆ 5µA Max Shutdown Current
- ◆ Preset 5V or Adjustable Output (3V to 16.5V)
- ◆ Current-Limited PFM Control Scheme
- ◆ Up to 300kHz Switching Frequency
- ◆ Evaluation Kit Available

## Applications

- High-Efficiency DC-DC Converters
- Battery-Powered Applications
- Positive LCD-Bias Generators
- Portable Communicators

## Ordering Information

PART	TEMP. RANGE	PIN-PACKAGE
MAX608C/D	0°C to +70°C	Dice*
MAX608EPA	-40°C to +85°C	8 Plastic DIP
MAX608ESA	-40°C to +85°C	8 SO

\* Contact factory for dice specifications.

## Typical Operating Circuit

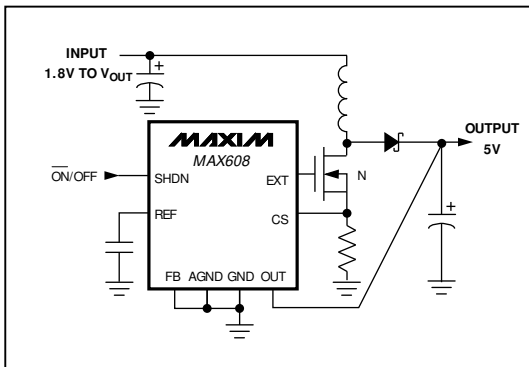

## Pin Configuration

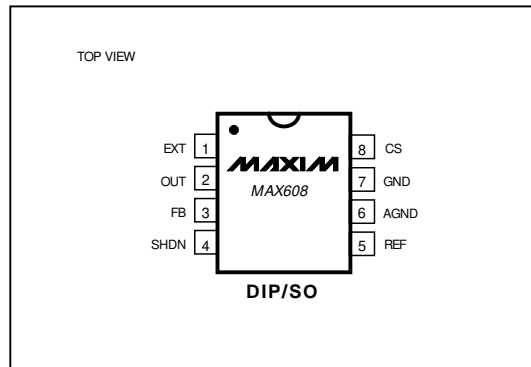

# 5V or Adjustable, Low-Voltage, Step-Up DC-DC Controller

## ABSOLUTE MAXIMUM RATINGS

Supply Voltage  
 OUT to GND .....-0.3V, 17V  
 EXT, CS, REF, SHDN, FB to GND .....-0.3V, (V<sub>OUT</sub> + 0.3V)  
 GND to AGND .....0.1V, -0.1V  
 Continuous Power Dissipation (T<sub>A</sub> = +70°C)  
 Plastic DIP (derate 9.09mW/°C above +70°C) .....727mW  
 SO (derate 5.88mW/°C above +70°C) .....471mW

Operating Temperature Range .....-40°C to +85°C  
 Junction Temperature .....+150°C  
 Storage Temperature Range .....-65°C to +160°C  
 Lead Temperature (soldering, 10sec) .....+300°C

Stresses beyond those listed under "Absolute Maximum Ratings" may cause permanent damage to the device. These are stress ratings only, and functional operation of the device at these or any other conditions beyond those indicated in the operational sections of the specifications is not implied. Exposure to absolute maximum rating conditions for extended periods may affect device reliability.

## ELECTRICAL CHARACTERISTICS

(V<sub>OUT</sub> = 5V, I<sub>LOAD</sub> = 0mA, T<sub>A</sub> = -40°C to +85°C where indicated. T<sub>A</sub> = -25°C to +85°C for all other limits. Typical values are at T<sub>A</sub> = +25°C.)

PARAMETER	SYMBOL	CONDITIONS	MIN	TYP	MAX	UNITS	
Input Voltage Range (Note 2)		T <sub>A</sub> = -25°C to +85°C	1.8		16.5	V	
		T <sub>A</sub> = -40°C to +85°C (Note 1)	1.9		16.5		
Minimum Start-Up Voltage		No load		1.6	1.8	V	
Supply Current		V <sub>OUT</sub> = 16.5V, SHDN ≤ 0.4V		85	110	μA	
			T <sub>A</sub> = -25°C to +85°C				120
		V <sub>OUT</sub> = 10V, SHDN ≥ 1.6V		2	5	μA	
			T <sub>A</sub> = -25°C to +85°C				10
Output Voltage (Note 3)		V <sub>IN</sub> = 2.0V to 5.0V, over full load range, circuit of Figure 2a		4.825	5.0	5.175	V
			T <sub>A</sub> = -25°C to +85°C			5.200	
Output Voltage Line Regulation (Note 4)		V <sub>IN</sub> = 2.7V to 4.0V, V <sub>OUT</sub> = 5V, I <sub>LOAD</sub> = 500mA, circuit of Figure 2a		7		mV/V	
Output Voltage Load Regulation (Note 4)		V <sub>IN</sub> = 2V, V <sub>OUT</sub> = 5V, I <sub>LOAD</sub> = 0mA to 500mA, circuit of Figure 2a		60		mV/A	
Maximum Switch On-Time	t <sub>ON(max)</sub>		12	16	20	μs	
Minimum Switch Off-Time	t <sub>OFF(min)</sub>		1.8	2.3	2.8	μs	
Efficiency		V <sub>IN</sub> = 4V, V <sub>OUT</sub> = 5V, I <sub>LOAD</sub> = 500mA, circuit of Figure 2a		87		%	
Reference Voltage	V <sub>REF</sub>	I <sub>REF</sub> = 0μA		1.4625	1.5	1.5375	V
			T <sub>A</sub> = -25°C to +85°C			1.5525	
REF Load Regulation		0μA ≤ I <sub>REF</sub> ≤ 100μA		-4	10	mV	
REF Line Regulation		3V ≤ V <sub>OUT</sub> ≤ 16.5V		40	100	μV/V	
FB Trip Point Voltage (Note 5)	V <sub>FB</sub>	T <sub>A</sub> = -25°C to +85°C	1.4625	1.5	1.5375	V	
		T <sub>A</sub> = -40°C to +85°C (Note 1)	1.4475		1.5525		
FB Input Current	I <sub>FB</sub>	T <sub>A</sub> = -25°C to +85°C		-4	±20	nA	
		T <sub>A</sub> = -40°C to +85°C (Note 1)			±40		
SHDN Input High Voltage	V <sub>IH</sub>	V <sub>OUT</sub> = 1.8V to 16.5V	1.6			V	
SHDN Input Low Voltage	V <sub>IL</sub>	V <sub>OUT</sub> = 1.8V to 16.5V			0.4	V	
SHDN Input Current	I <sub>IN</sub>	V <sub>OUT</sub> = 16.5V, SHDN = 0V or 16.5V			±1	μA	

# 5V or Adjustable, Low-Voltage, Step-Up DC-DC Controller

MAX608

## ELECTRICAL CHARACTERISTICS (continued)

( $V_{OUT} = 5V$ ,  $I_{LOAD} = 0mA$ ,  $T_A = -40^{\circ}C$  to  $+85^{\circ}C$  where indicated.  $T_A = -25^{\circ}C$  to  $+85^{\circ}C$  for all other limits. Typical values are at  $T_A = +25^{\circ}C$ .)

PARAMETER	SYMBOL	CONDITIONS	MIN	TYP	MAX	UNITS	
Current-Limit Trip Level	VCS	$V_{OUT} = 3V$ to $16.5V$	$T_A = -25^{\circ}C$ to $+85^{\circ}C$	85	100	115	mV
			$T_A = -40^{\circ}C$ to $+85^{\circ}C$ (Note 1)	80		120	
CS Input Current	Ics			0.01	$\pm 1$	$\mu A$	
EXT Rise Time		$V_{OUT} = 5V$ , 1nF from EXT to GND		50		ns	
EXT Fall Time		$V_{OUT} = 5V$ , 1nF from EXT to GND		50			
EXT On-Resistance		EXT = high or low		15	30	$\Omega$	

**Note 1:** Limits over this temperature range are guaranteed by design.

**Note 2:** The MAX608 must be operated in bootstrapped mode with OUT connected to the DC-DC circuit output. The minimum output voltage set point is +3V.

**Note 3:** Output voltage guaranteed using preset voltages. See Figures 4a–4d for output current capability versus input voltage.

**Note 4:** Output voltage line and load regulation depend on external circuit components.

**Note 5:** Operation in the external-feedback mode is guaranteed to be accurate to the  $V_{FB}$  trip level, and does not include resistor tolerance.

## Typical Operating Characteristics

( $T_A = +25^{\circ}C$ , unless otherwise noted.)

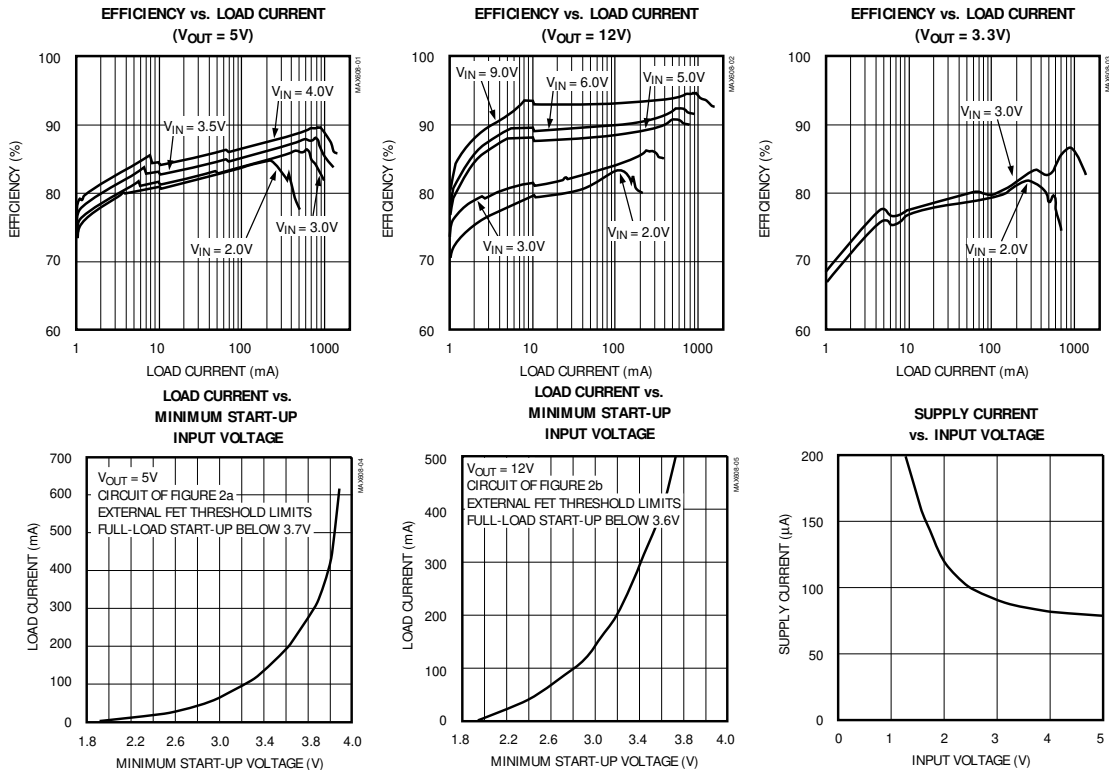

# 5V or Adjustable, Low-Voltage, Step-Up DC-DC Controller

## Typical Operating Characteristics (continued)

( $T_A = +25^\circ\text{C}$ , unless otherwise noted.)

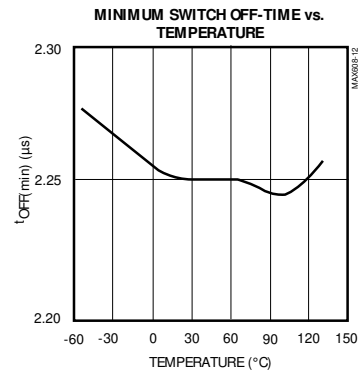
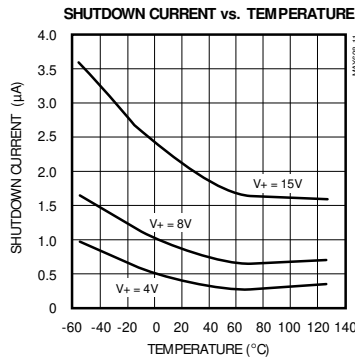
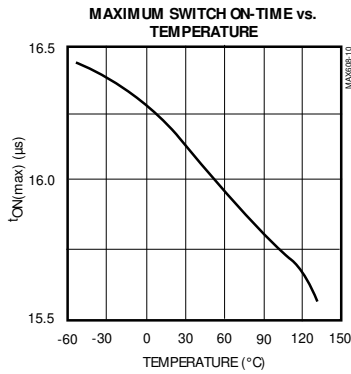
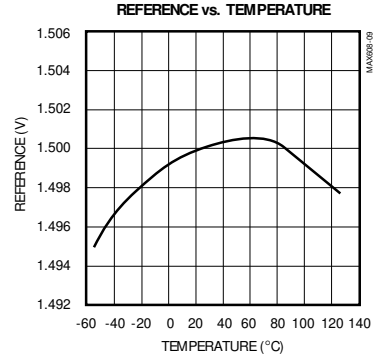
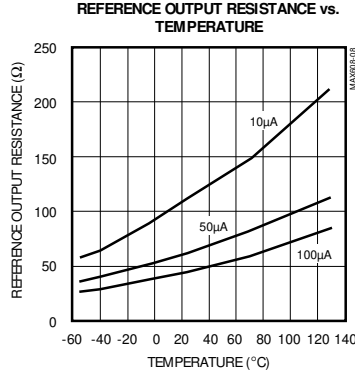
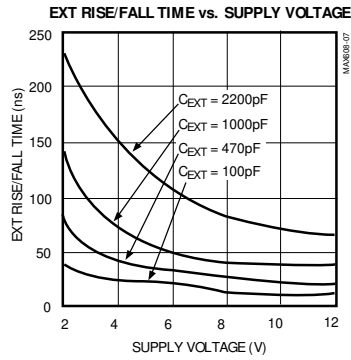

**HEAVY-LOAD SWITCHING WAVEFORMS**  
( $V_{OUT} = 5\text{V}$ )

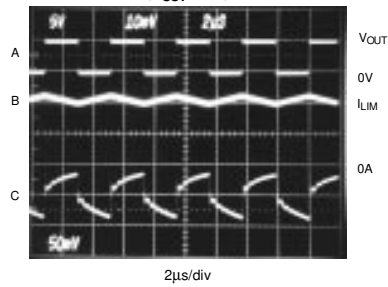

$V_{IN} = 3\text{V}$ ,  $I_{OUT} = 930\text{mA}$ ,  $V_{OUT} = 5\text{V}$   
A = EXT VOLTAGE, 5V/div  
B = INDUCTOR CURRENT, 1A/div  
C =  $V_{OUT}$  RIPPLE, 50mV/div, AC-COUPLED

**MEDIUM-LOAD SWITCHING WAVEFORMS**  
( $V_{OUT} = 5\text{V}$ )

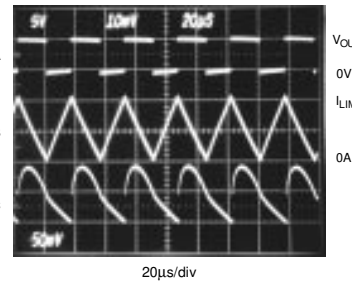

$V_{IN} = 3\text{V}$ ,  $I_{OUT} = 490\text{mA}$ ,  $V_{OUT} = 5\text{V}$   
A = EXT VOLTAGE, 5V/div  
B = INDUCTOR CURRENT, 1A/div  
C =  $V_{OUT}$  RIPPLE, 50mV/div, AC-COUPLED

# 5V or Adjustable, Low-Voltage, Step-Up DC-DC Controller

MAX608

## Typical Operating Characteristics (continued)

( $T_A = +25^\circ\text{C}$ , unless otherwise noted.)

**HEAVY-LOAD SWITCHING WAVEFORMS**  
( $V_{OUT} = 12\text{V}$ )

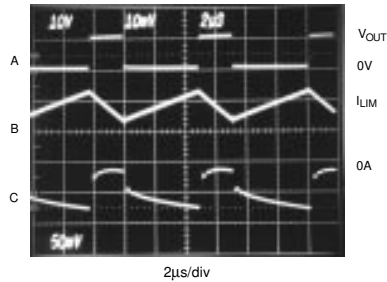

$V_{IN} = 4\text{V}$ ,  $I_{OUT} = 490\text{mA}$ ,  $V_{OUT} = 12\text{V}$   
A = EXT VOLTAGE, 10V/div  
B = INDUCTOR CURRENT, 1A/div  
C =  $V_{OUT}$  RIPPLE, 50mV/div, AC-COUPLED

**MEDIUM-LOAD SWITCHING WAVEFORMS**  
( $V_{OUT} = 12\text{V}$ )

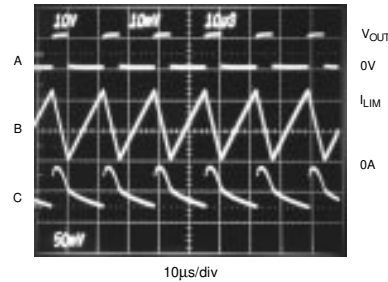

$V_{IN} = 4\text{V}$ ,  $I_{OUT} = 300\text{mA}$ ,  $V_{OUT} = 12\text{V}$   
A = EXT VOLTAGE, 10V/div  
B = INDUCTOR CURRENT, 1A/div  
C =  $V_{OUT}$  RIPPLE, 50mV/div, AC-COUPLED

**LINE-TRANSIENT RESPONSE**  
( $V_{OUT} = 5\text{V}$ )

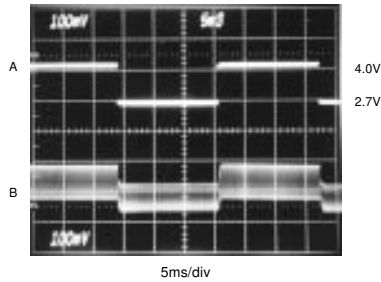

$I_{OUT} = 500\text{mA}$ ,  $V_{OUT} = 5\text{V}$   
A =  $V_{IN}$ , 2.7V TO 4.0V, 1V/div  
B =  $V_{OUT}$  RIPPLE, 100mV/div, AC-COUPLED

**LOAD-TRANSIENT RESPONSE**  
( $V_{OUT} = 5\text{V}$ )

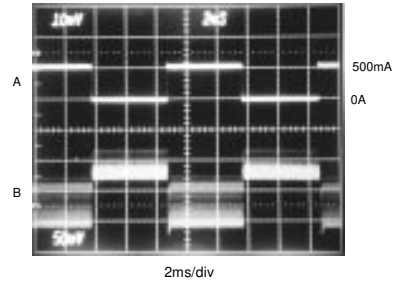

$V_{IN} = 2\text{V}$ ,  $V_{OUT} = 5\text{V}$   
A = LOAD CURRENT, 0mA TO 500mA, 500mA/div  
B =  $V_{OUT}$  RIPPLE, 50mV/div, AC-COUPLED

**EXITING SHUTDOWN**

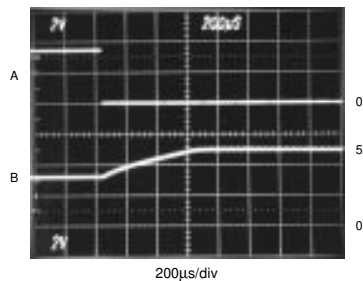

$I_{OUT} = 500\text{mA}$ ,  $V_{IN} = 3.5\text{V}$   
A = SHDN, 2V/div  
B =  $V_{OUT}$ , 2V/div

# 5V or Adjustable, Low-Voltage, Step-Up DC-DC Controller

## Pin Description

PIN	NAME	FUNCTION
1	EXT	Gate Drive for External N-Channel Power Transistor
2	OUT	Power-Supply and Voltage-Sense Input. Always connect OUT to circuit output.
3	FB	Feedback Input for Adjustable-Output Operation. Connect to ground for fixed-output operation. Use a resistor divider network to adjust the output voltage. See <i>Setting the Output Voltage</i> section.
4	SHDN	Active-High TTL/CMOS Logic-Level Shutdown Input. In shutdown mode, $V_{OUT}$ is a diode drop below the input voltage (due to the DC path from the input voltage to the output). Connect to ground for normal operation.
5	REF	1.5V Reference Output that can source 100 $\mu$ A for external loads. Bypass to GND with 0.1 $\mu$ F. The reference is disabled in shutdown.
6	AGND	Analog Ground
7	GND	High-Current Ground Return for the Output Driver
8	CS	Positive Input to the Current-Sense Amplifier. Connect the current-sense resistor between CS and AGND.

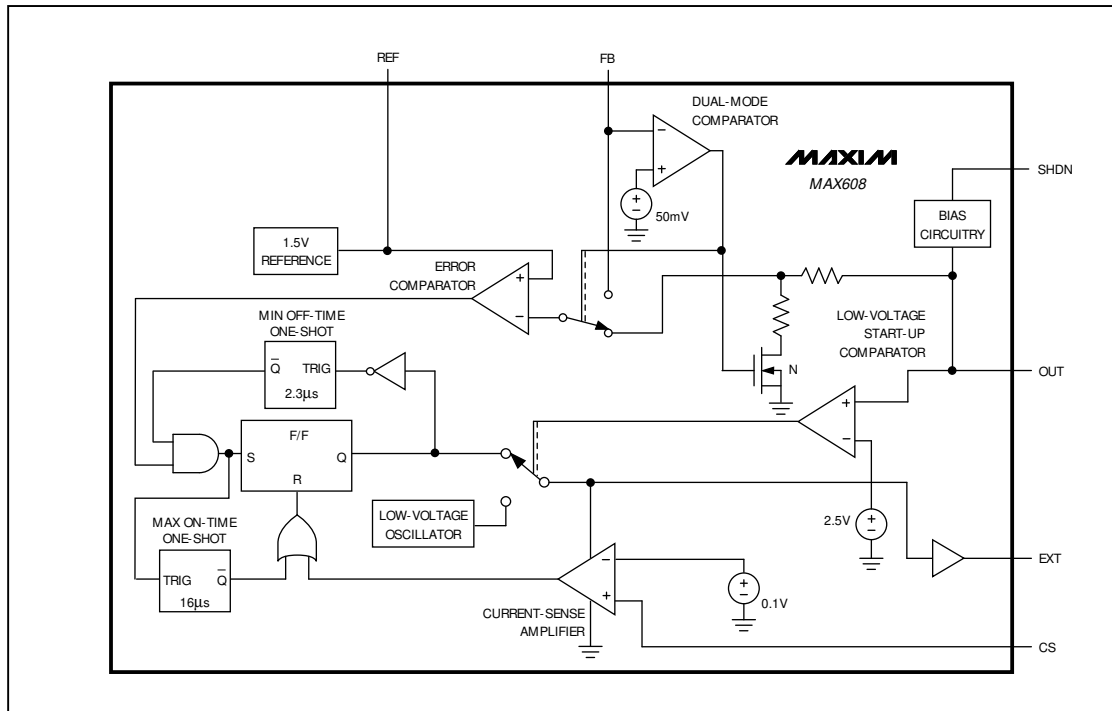

Figure 1. Functional Diagram

## 5V or Adjustable, Low-Voltage, Step-Up DC-DC Controller

MAX608

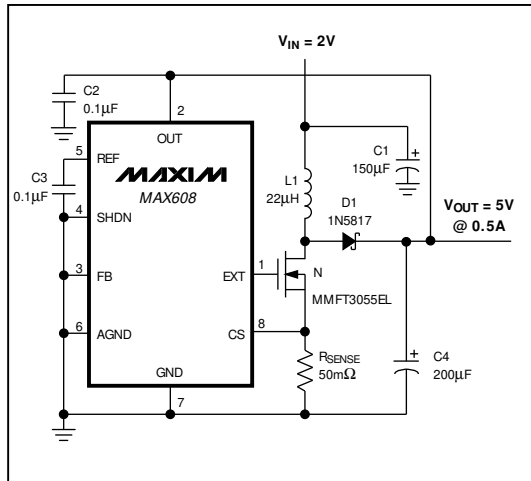

Figure 2a. 5V Preset Output

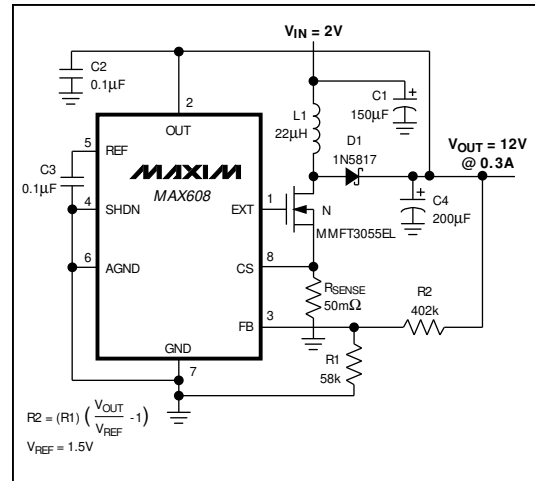

Figure 2b. 12V Output

### Detailed Description

The MAX608 is a BiCMOS, step-up, switch-mode power-supply controller that provides a preset 5V output, in addition to adjustable-output operation. Its unique control scheme combines the advantages of pulse-frequency modulation (low supply current) and pulse-width modulation (high efficiency with heavy loads), providing high efficiency over a wide output current range, as well as increased output current capability over previous PFM devices. In addition, the external sense resistor and power transistor allow the user to tailor the output current capability for each application. Figure 1 shows the MAX608 functional diagram. The device has a shut-down mode that reduces the supply current to 5µA max.

Figure 2 shows the standard application circuits. The IC is powered from the output, and the input voltage range is 1.8V to  $V_{OUT}$  (this configuration is commonly known as bootstrap operation). The voltage applied to the gate of the external power transistor is switched from  $V_{OUT}$  to ground.

The MAX608's output voltage can be set to 5V by connecting FB to ground; it can also be adjusted from 3V to 16.5V using external resistors. Use 1% external feedback resistors when operating in adjustable-output mode (Figures 2b, 2c) to achieve an overall output voltage accuracy of  $\pm 5\%$ .

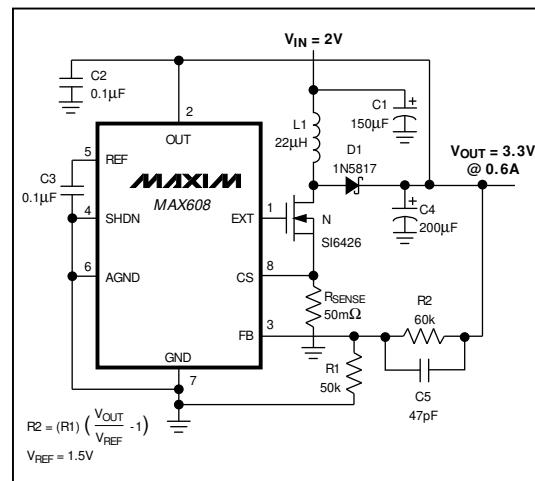

Figure 2c. 3.3V Output

### PFM Control Scheme

The MAX608 uses a proprietary current-limited PFM control scheme to provide high efficiency over a wide range of load currents. This control scheme combines the ultra-low supply current of PFM converters (or pulse skippers) with the high full-load efficiency of PWM converters.

## 5V or Adjustable, Low-Voltage, Step-Up DC-DC Controller

Unlike traditional PFM converters, the MAX608 uses a sense resistor to control the peak inductor current. The device also operates with high switching frequencies (up to 300kHz), allowing the use of miniature external components.

As with traditional PFM converters, the power transistor is not turned on until the voltage comparator senses the output is out of regulation. However, unlike traditional PFM converters, the MAX608 switch uses the combination of a peak current limit and a pair of one-shots that set the maximum on-time (16 $\mu$ s) and minimum off-time (2.3 $\mu$ s); there is no oscillator. Once off, the minimum off-time one-shot holds the switch off for 2.3 $\mu$ s. After this minimum time, the switch either 1) stays off if the output is in regulation, or 2) turns on again if the output is out of regulation.

The control circuitry allows the IC to operate in continuous-conduction mode (CCM) while maintaining high efficiency with heavy loads. When the power switch is turned on, it stays on until either 1) the maximum on-time one-shot turns it off (typically 16 $\mu$ s later), or 2) the switch current reaches the peak current limit set by the current-sense resistor.

The MAX608 switching frequency is variable (depending on load current and input voltage), causing variable switching noise. However, the subharmonic noise generated does not exceed the peak current limit times the filter capacitor equivalent series resistance (ESR). For example, when generating a 5V output at 500mA from a 2V input, only 75mV of output ripple occurs, using the circuit of Figure 2a.

### Low-Voltage Start-Up Oscillator

The MAX608 features a low input voltage start-up oscillator that guarantees start-up with no load for input voltages down to 1.8V. At these low voltages, the output voltage is not large enough for proper error-comparator operation and internal biasing. The start-up oscillator has a fixed 50% duty cycle and the MAX608 disregards the error-comparator output when the output voltage is less than 2.5V. Above 2.5V, the error-comparator and normal one-shot timing circuitry are used.

### Shutdown Mode

When SHDN is high, the MAX608 enters shutdown mode. In this mode, the internal biasing circuitry is turned off (including the reference), and  $V_{OUT}$  falls to a diode drop below  $V_{IN}$  (due to the DC path from the input to the output). In shutdown mode, the supply current drops to less than 5 $\mu$ A. SHDN is a TTL/CMOS logic-level input. Connect SHDN to GND for normal operation.

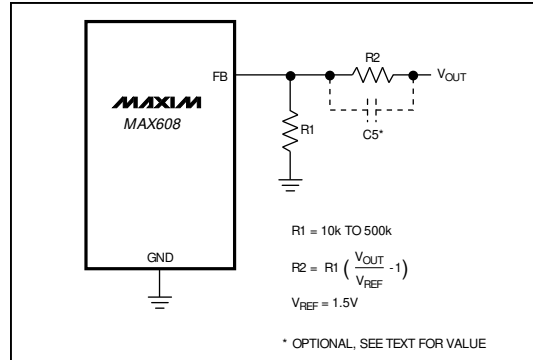

Figure 3. Adjustable Output Circuit

## Design Procedure

### Setting the Output Voltage

The MAX608's output voltage is preset to 5V ( $FB = 0V$ ), or it can be adjusted from 16.5V down to 3V using external resistors  $R1$  and  $R2$ , configured as shown in Figure 3. For adjustable-output operation, select feedback resistor  $R1$  in the 10k $\Omega$  to 500k $\Omega$  range.  $R2$  is given by:

$$R2 = (R1) \left( \frac{V_{OUT}}{V_{REF}} - 1 \right)$$

where  $V_{REF}$  equals 1.5V.

$OUT$  must always be connected to the circuit output.

Figure 2 shows various circuit configurations for preset/adjustable operation.

### Determining $R_{SENSE}$

Use the theoretical output current curves shown in Figures 4a–4d to select  $R_{SENSE}$ . They are derived using the minimum (worst-case) current-limit comparator threshold value over the extended temperature range (-40 $^{\circ}$ C to +85 $^{\circ}$ C). No tolerance was included for  $R_{SENSE}$ . The voltage drop across the diode is assumed to be 0.5V, and the drop across the power switch  $r_{DS(ON)}$  and coil resistance is assumed to be 0.3V.

### Determining the Inductor ( $L$ )

Practical inductor values range from 10 $\mu$ H to 300 $\mu$ H. 22 $\mu$ H is a good choice for most applications. In applications with large input/output differentials, the IC's output-current capability will be much less when the inductance value is too low, because the IC will always operate in discontinuous mode. If the inductor value is too low, the



## 5V or Adjustable, Low-Voltage, Step-Up DC-DC Controller

MAX608

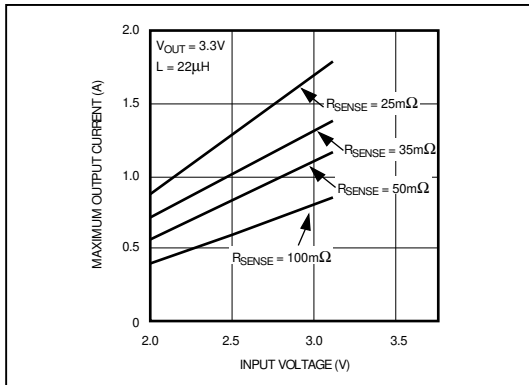

Figure 4a. Maximum Output Current vs. Input Voltage ( $V_{OUT} = 3.3V$ )

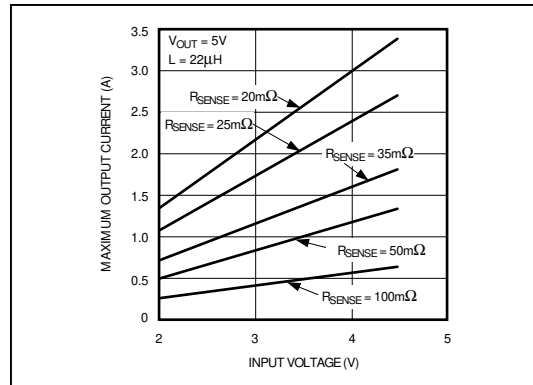

Figure 4b. Maximum Output Current vs. Input Voltage ( $V_{OUT} = 5V$ )

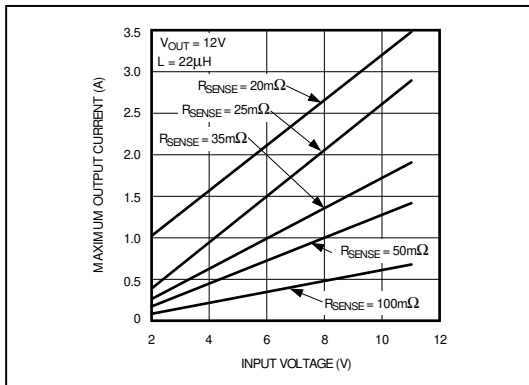

Figure 4c. Maximum Output Current vs. Input Voltage ( $V_{OUT} = 12V$ )

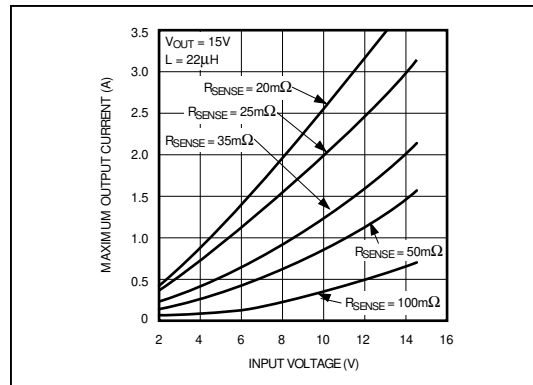

Figure 4d. Maximum Output Current vs. Input Voltage ( $V_{OUT} = 15V$ )

current will ramp up to a high level before the current-limit comparator can turn off the switch. The minimum on-time for the switch ( $t_{ON(min)}$ ) is approximately  $2\mu s$ ; select an inductor that allows the current to ramp up to  $I_{LIM}$ .

The standard operating circuits use a  $22\mu H$  inductor. If a different inductance value is desired, select  $L$  such that:

$$L \geq \frac{V_{IN(max)} \times 2\mu s}{I_{LIM}}$$

Larger inductance values tend to increase the start-up time slightly, while smaller inductance values allow the coil current to ramp up to higher levels before the switch turns off, increasing the ripple at light loads.

Inductors with a ferrite core or equivalent are recommended; powder iron cores are not recommended for use with high switching frequencies. Make sure the inductor's saturation current rating (the current at which the core begins to saturate and the inductance starts to fall) exceeds the peak current rating set by  $R_{SENSE}$ . However, it is generally acceptable to bias the inductor into saturation by approximately 20% (the point where the inductance is 20% below the nominal value). For highest efficiency, use a coil with low DC resistance, preferably under  $20m\Omega$ . To minimize radiated noise, use a toroid, a pot core, or a shielded coil.

Table 1 lists inductor suppliers and specific recommended inductors.

## 5V or Adjustable, Low-Voltage, Step-Up DC-DC Controller

### Power Transistor Selection

Use an N-channel MOSFET power transistor with the MAX608.

Use logic-level or low-threshold N-FETs to ensure the external N-channel MOSFET (N-FET) is turned on completely and that start-up occurs. N-FETs provide the highest efficiency because they do not draw any DC gate-drive current.

When selecting an N-FET, some important parameters to consider are the total gate charge ( $Q_g$ ), on-resistance ( $r_{DS(ON)}$ ), reverse transfer capacitance ( $C_{RSS}$ ), maximum drain to source voltage ( $V_{DS \text{ max}}$ ), maximum gate to source voltage ( $V_{GS \text{ max}}$ ), and minimum threshold voltage ( $V_{TH \text{ min}}$ ).

$Q_g$  takes into account all capacitances associated with charging the gate. Use the typical  $Q_g$  value for best results; the maximum value is usually grossly over-specified since it is a guaranteed limit and not the measured value. The typical total gate charge should be 50nC or less. With larger numbers, the EXT pins may not be able to adequately drive the gate. The EXT rise/fall time varies with different capacitive loads as shown in the *Typical Operating Characteristics*.

The two most significant losses contributing to the N-FET's power dissipation are  $I^2R$  losses and switching losses. Select a transistor with low  $r_{DS(ON)}$  and low  $C_{RSS}$  to minimize these losses.

Determine the maximum required gate-drive current from the  $Q_g$  specification in the N-FET data sheet.

Select an N-FET with a  $BV_{DSS} > V_{OUT}$ ,  $BV_{GSS} > V_{OUT}$ , and a minimum  $V_{TH}$  of 0.5V below the minimum input voltage.

When using a power supply that decays with time (such as a battery), the N-FET transistor will operate in its linear region when the voltage at EXT approaches the threshold voltage of the FET, dissipating excessive power. Prolonged operation in this mode may damage the FET. To avoid this condition, make sure  $V_{EXT}$  is above the  $V_{TH}$  of the FET, or use a voltage detector (such as the MAX8211) to put the IC in shutdown mode once the input supply voltage falls below a predetermined minimum value. Excessive loads with low input voltages can also cause this condition.

The MAX608's maximum allowed switching frequency during normal operation is 300kHz. However, at start-up, the maximum frequency can be 500kHz, so the maximum current required to charge the N-FET's gate is  $f(\text{max}) \times Q_g(\text{typ})$ . Use the typical  $Q_g$  number from the transistor data sheet. For example, the MMFT3055EL has a  $Q_g(\text{typ})$  of 7nC (at  $V_{GS} = 5V$ ), therefore the current required to charge the gate is:

$$I_{GATE(\text{max})} = (500\text{kHz}) (7\text{nC}) = 3.5\text{mA}.$$

Figure 2a's application circuit uses a 4-pin MMFT3055EL surface-mount N-FET that has 150m $\Omega$  on-resistance with 4.5V  $V_{GS}$ , and a guaranteed  $V_{TH}$  of less than 2V. Figure 2c's application circuit uses an Si6426DQ logic-level N-FET with a threshold voltage ( $V_{TH}$ ) of 1V.

### Diode Selection

The MAX608's high switching frequency demands a high-speed rectifier. Schottky diodes such as the 1N5817–1N5822 are recommended. Make sure the Schottky diode's average current rating exceeds the peak current limit set by  $R_{SENSE}$ , and that its breakdown voltage exceeds  $V_{OUT}$ . For high-temperature applications, Schottky diodes may be inadequate due to their high leakage currents; high-speed silicon diodes such as the MUR105 or EC11FS1 can be used instead. At heavy loads and high temperatures, the benefits of a Schottky diode's low forward voltage may outweigh the disadvantage of high leakage current.

### Capacitor Selection

#### Output Filter Capacitor

The primary criterion for selecting the output filter capacitor ( $C_4$ ) is low effective series resistance (ESR). The product of the peak inductor current and the output filter capacitor's ESR determines the amplitude of the ripple seen on the output voltage. Two OS-CON 100 $\mu$ F, 16V output filter capacitors in parallel with 35m $\Omega$  of ESR each typically provide 75mV ripple when stepping up from 2V to 5V at 500mA (Figure 2a). Smaller-value and/or higher-ESR capacitors are acceptable for light loads or in applications that can tolerate higher output ripple.

Since the output filter capacitor's ESR affects efficiency, use low-ESR capacitors for best performance. See Table 1 for component selection.

#### Input Bypass Capacitors

The input bypass capacitor ( $C_1$ ) reduces peak currents drawn from the voltage source and also reduces noise caused by the switching action of the MAX608 at the voltage source. The input voltage source impedance determines the size of the capacitor required at the OUT input. As with the output filter capacitor, a low-ESR capacitor is recommended. For output currents up to 1A, 150 $\mu$ F ( $C_1$ ) is adequate, although smaller bypass capacitors may also be acceptable.

Bypass the IC with a 0.1 $\mu$ F ceramic capacitor ( $C_2$ ) placed as close as possible to the OUT and GND pins.

#### Reference Capacitor

Bypass REF with a 0.1 $\mu$ F capacitor ( $C_3$ ). REF can source up to 100 $\mu$ A of current for external loads.

## 5V or Adjustable, Low-Voltage, Step-Up DC-DC Controller

**MAX608**

PRODUCTION	INDUCTORS	CAPACITORS	TRANSISTORS	DIODES
Surface Mount	Sumida CD54 series CDR125 series Coiltronics CTX20 series Coilcraft DO3316 series DO3340 series	Matsuo 267 series Sprague 595D series AVX TPS series Sanyo OS-CON series	Siliconix Si9410DY Si4410DY Si6426DQ Si6946DQ Motorola MTP3055EL MTD20N03HDL MMFT3055ELT1	Central Semiconductor CMPSH-3 CMPZ5240 Nihon EC11 FS1 series (high-speed silicon) Motorola MBRS1100T3 MMBZ5240BL
Through Hole	Sumida RCH855 series RCH110 series	Sanyo OS-CON series Nichicon PL series		Motorola 1N5817-1N5822 MUR105 (high-speed silicon)

### **Feed-Forward Capacitor**

When adjusting the output voltage, it may be necessary to parallel a 47pF to 220pF capacitor across R2, as shown in Figures 2 and 3. Choose the lowest capacitor value that insures stability; high capacitance values may degrade line regulation.

### **Applications Information**

#### **Starting Up Under Load**

The *Typical Operating Characteristics* show the Start-Up Voltage vs. Load Current graphs for 5V and 12V output voltages. These graphs depend on the type of power switch used. The MAX608 is not designed to start up under full load with low input voltages.

#### **Layout Considerations**

Due to high current levels and fast switching waveforms, which radiate noise, proper PC board layout is essential. Protect sensitive analog grounds by using a star ground configuration. Minimize ground noise by connecting GND, the input bypass capacitor ground lead, and the output filter capacitor ground lead to a single point (star ground configuration). Also, minimize lead lengths to reduce stray capacitance, trace resistance, and radiated noise. Place input bypass capacitor C2 as close as possible to OUT and GND.

**If an external resistor divider is used (Figures 2 and 3), the trace from FB to the resistors must be extremely short.**

SUPPLIER	PHONE	FAX
AVX	USA: (803) 448-9411	(803) 448-1943
Central Semiconductor	USA: (516) 435-1110	(516) 435-1824
Coilcraft	USA: (708) 639-6400	(708) 639-1469
Coiltronics	USA: (407) 241-7876	(407) 241-9339
Matsuo	USA: (714) 969-2491 Japan: 81-6-337-6450	(714) 960-6492 81-6-337-6456
Motorola	USA: (800) 521-6274	(602) 952-4190
Nichicon	USA: (708) 843-7500	(708) 843-2798
Nihon	USA: (805) 867-2555	(805) 867-2556
Sanyo	USA: (619) 661-6835 Japan: 81-7-2070-1005	(619) 661-1055 81-7-2070-1174
Siliconix	USA: (800) 554-5565	(408) 970-3950
Sprague	USA: (603) 224-1961	(603) 224-1430
Sumida	USA: (708) 956-0666 Japan: 81-3-3607-5111	(708) 956-0702 81-3-3607-5144

# 5V or Adjustable, Low-Voltage, Step-Up DC-DC Controller

**MAX608**

## Chip Topography

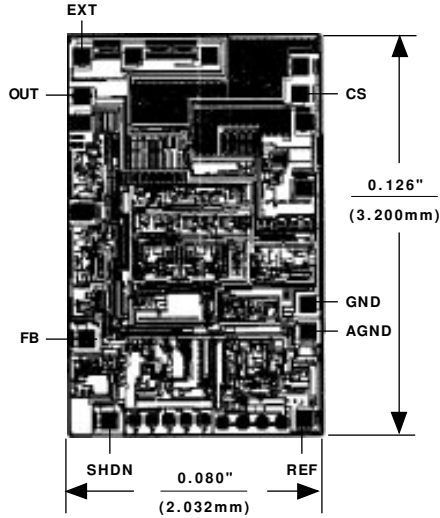

TRANSISTOR COUNT: 501  
SUBSTRATE CONNECTED TO OUT

## Package Information

DIM	INCHES		MILLIMETERS	
	MIN	MAX	MIN	MAX
A	0.053	0.069	1.35	1.75
A1	0.004	0.010	0.10	0.25
B	0.014	0.019	0.35	0.49
C	0.007	0.010	0.19	0.25
E	0.150	0.157	3.80	4.00
e	0.050		1.27	
H	0.228	0.244	5.80	6.20
L	0.016	0.050	0.40	1.27

**Narrow SO  
SMALL-OUTLINE  
PACKAGE  
(0.150 in.)**

DIM	PINS	INCHES		MILLIMETERS	
		MIN	MAX	MIN	MAX
D	8	0.189	0.197	4.80	5.00
D	14	0.337	0.344	8.55	8.75
D	16	0.386	0.394	9.80	10.00

21-0041A