

W48-X-X-X-X-X-X

SWITCH FUNCTION CODE	SWITCH FUNCTION DESCRIPTION
1	MECHANICAL, MOMENTARY, SOLDER TERMINAL (LED WIRELEADS)
2	MECHANICAL, MAINTAINED, SOLDER TERMINAL (LED WIRELEADS)
5	MECHANICAL, MOMENTARY, P.C. TERMINAL (LED WIRELEADS)
6	MECHANICAL, MAINTAINED, P.C. TERMINAL (LED WIRELEADS)

BEZEL CODE	BEZEL DESCRIPTION
RB	ROUND, BLACK
SB	SQUARE, BLACK (ONLY FOR BUSHING MOUNTING)

ILLUMINATION CODE	LED COLOR DESCRIPTION
N	NO LED
R	RED
A	AMBER
Y	YELLOW
G	GREEN
B	BLUE
W	WHITE
RG	RED/BLUE
RB	RED/GREEN

BUTTON CODE (SEE NOTE 3)	BUTTON COLOR DESCRIPTION
(H)BK	BLACK
(H)RD	RED
(H)GR	GREEN
(H)BL	BLUE
(H)YL	YELLOW
(H)OR	ORANGE
(H)WH	WHITE
PK	POWER/STANDBY BLACK (ONLY FOR ROUND BEZEL & BUSHING MOUNT)

MOUNTING CODE	MOUNTING STYLE DESCRIPTION
B	BUSHING
F	SNAP-FIT (ONLY FOR ROUND BEZEL)

LED VOLTAGE CODE	LED VOLTAGE DESCRIPTION
IF BLANK	SEE LED SPEC.
05	5V (SEE NOTE 4)

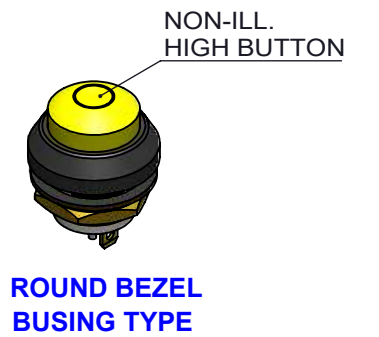

MECHANICAL CHARACTERISTICS:
 SWITCH CIRCUITRY: SPST-NO-DB
 SWITCH ACTION: MOMENTARY AND MAINTAINED (PER CHART)
 BUTTON TRAVEL: 2.3mm NOMINAL
 OPERATING FORCE: 3N [306g] NOMINAL
 PANEL THICKNESS:
 BUSHING MOUNT: 0.5 - 3.0mm
 SNAP MOUNT: 1mm/2mm/3mm ±0.05
 CONTACTS: GOLD PLATED
 NUT TORQUE FORCE: MAX 6 kgf-cm [5.2 LB-in]
 ENVIRONMENTAL SPECIFICATIONS:
 ACTUATOR INGRESS PROTECTION: IP67

LIFE (MECHANICAL):
 MOMENTARY: 1,000K CYCLES
 MAINTAINED: 50K CYCLES
OPERATING TEMPERATURE:
 MOMENTARY: -40°C to +85°C
 MAINTAINED: -40°C to +65°C
ELECTRICAL SPECIFICATIONS:
 CURRENT RATINGS:
 MOMENTARY: 10mA@12VDC, 1,000K CYCLES NOMINAL
 MAINTAINED: 50K CYCLES NOMINAL
 DIELECTRIC STRENGTH: 1,000VAC
 INSULATION RESISTANCE: 1G OHM
 CONTACT RESISTANCE:
 50m OHMS MAX INITIAL

CABLE: UL1007, AWG26

NOTE
 1. CURRENT LIMITING RESISTOR IS REQUIRED TO LIMIT LED FORWARD CURRENT TO 20mA
 2. SUPPLY HEX NUT AND SEALING WASHER BULK PACKED.
 3. HIGH-BUTTON OPTION, DENOTED (H), ONLY AVAILABLE FOR ROUND BEZEL AND NON-ILL. TYPE. OMIT (H) FOR STANDARD BUTTON.
 4. INNER RESISTOR ONLY FOR LED :RED / BLUE / GREEN / WHITE.

LED SPECIFICATION					
LED CODE	LED SINGLE COLOR	Vf(VDC)	If (mA)	CIRCUITRY	
		TYP.			
R	RED	2.0	20		
A	AMBER	2.0	20		
Y	YELLOW	2.0	20		
G	GREEN	3.0	20		
B	BLUE	3.1	20		
W	WHITE	3.3	20		
LED CODE	BICOLOR LED		Vf(VDC)	If (mA)	CIRCUITRY
	COLOR1	COLOR2	TYP.		
RB	RED	BLUE	2.0(RED) 3.3(BLUE)	20	
RG	RED	GREEN	2.0(RED) 3.4(GREEN)	20	

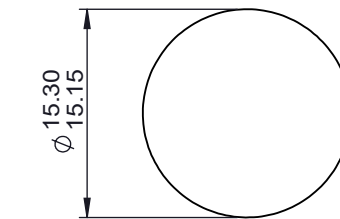
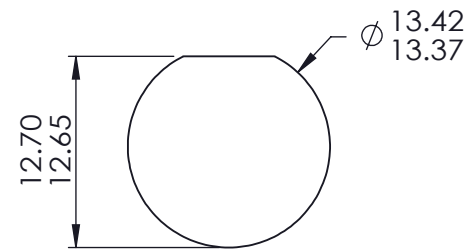

PANEL THICKNESS: 1.0mm, 2.0mm, 3.0mm ±0.05

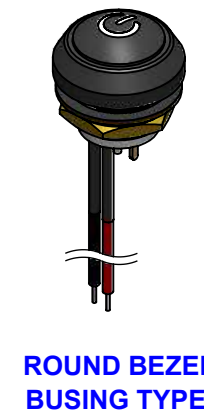
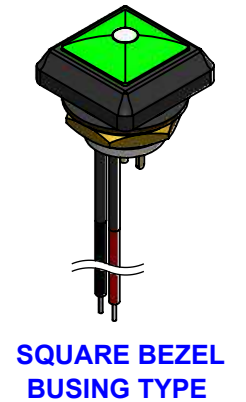
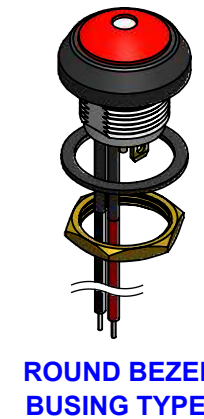

DWG TYPE SALES DRAWING	DRAWN <i>K.Y.</i>	TOLERANCES: UNLESS OTHERWISE NOTED X.X ± 0.5 X.XX ± 0.25 ANGULAR ± 5°	DWG TITLE W48- SERIES ,MECHANICAL MOMENTARY/MAINTAINED							
STATUS RELEASE	REVIEW <i>v.w.</i>	THIRD ANGLE PROJECTION 	DWG NO. W48-1,2,5,6							
This document is the intellectual property of ITW Electronic Business Asia Co., Limited and may contain confidential, proprietary, privileged information protected by law. Neither this document nor any information it contains can be reproduced, transformed to any other format, or distributed, without written permission by ITW Electronic Business Asia Co., Limited. 本文件為安達維百電股份有限公司之智慧財產，非經許可不得翻取、複製、轉變成其他形式使用或散佈。			DATE	REF: ---	<input checked="" type="checkbox"/> 管制文件 <input type="checkbox"/> 非管制文件	Unit mm	SCALE -	REV 1	RoHS Compliant	SHEET 1 OF 3

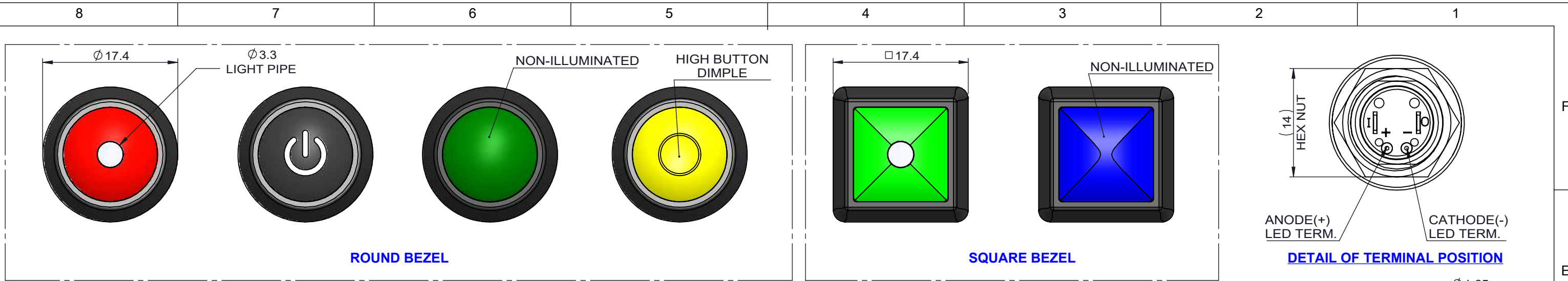

BUSHING TYPE

SNAP FIT TYPE

SWITCH ACTION	BUTTON TYPE	FP(mm)
MOMENTARY	NON-ILLUMINATION OR POWER /STANDBY	8.0±0.5
	ILLUMINATION LIGHT PIPE BUTTON	7.6±0.5
	NON-ILLUMINATION HIGH BUTTON	9.9±0.5
MAINTAINED	NON-ILLUMINATION OR POWER /STANDBY	6.5±0.5
	ILLUMINATION LIGHT PIPE BUTTON	6.0±0.5
	NON-ILLUMINATION HIGH BUTTON	8.4±0.5

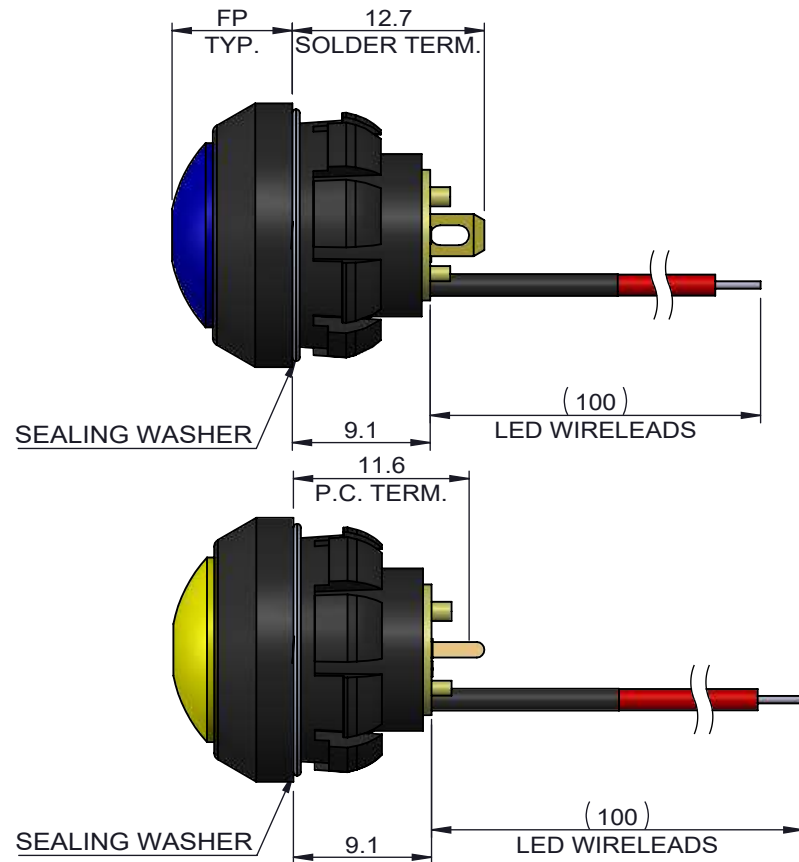
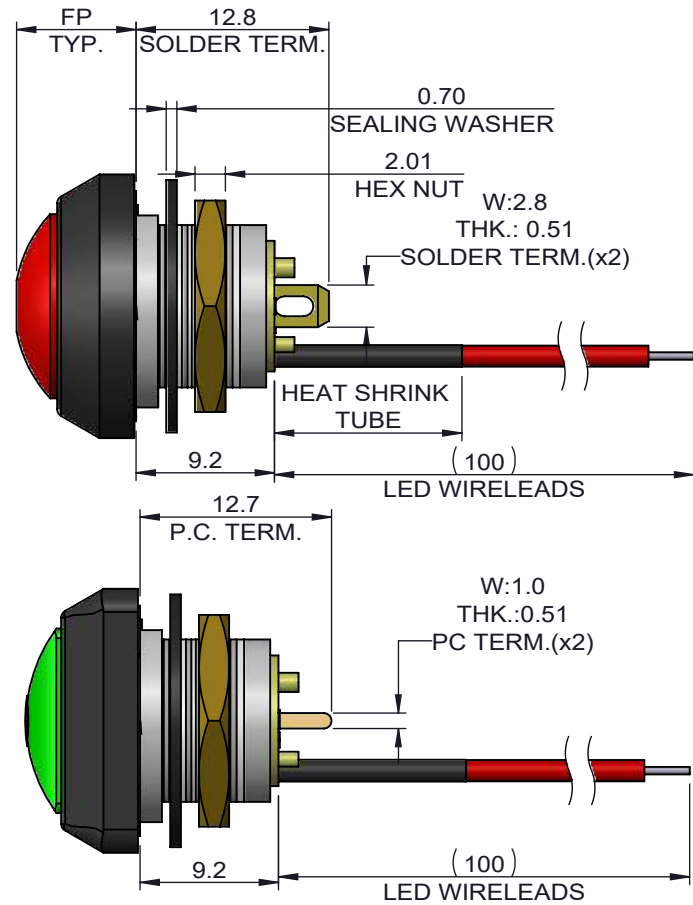
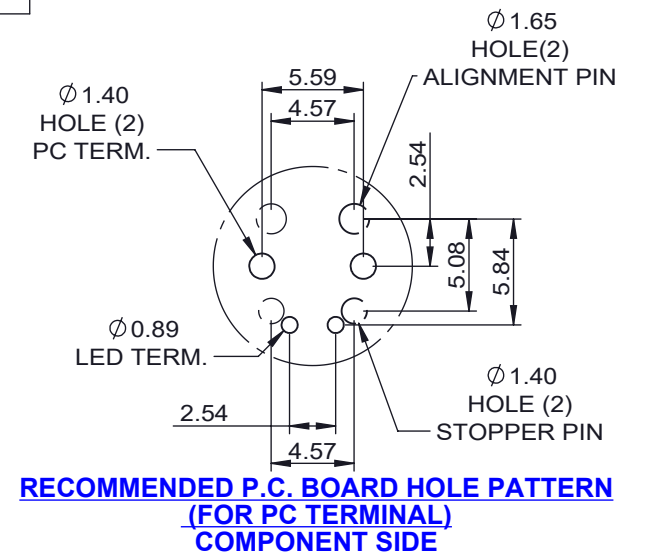

BUSHING TYPE NON-ILL.

SNAP FIT TYPE NON-ILL.

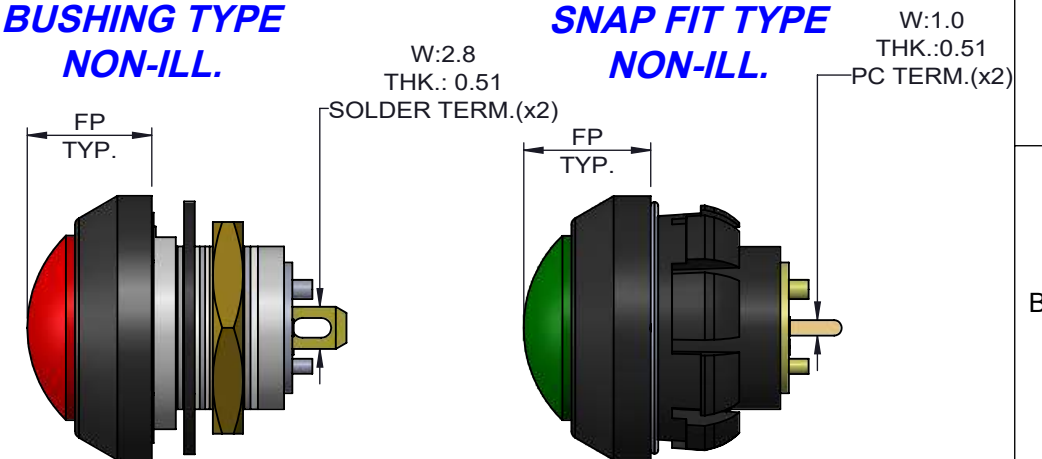

DWG TYPE SALES DRAWING	DRAWN <i>K.Y.</i>	TOLERANCES: UNLESS OTHERWISE NOTED X.X ± 0.5 X.XX ± 0.25 ANGULAR ± 5°	DWG TITLE W48- SERIES ,MECHANICAL MOMENTARY/MAINTAINED							
STATUS RELEASE	REVIEW <i>v.w.</i>	THIRD ANGLE PROJECTION 	DWG NO. W48-1,2,5,6							
<small>This document is the intellectual property of ITW Electronic Business Asia Co., Limited and may contain confidential, proprietary, privileged information protected by law. Neither this document nor any information it contains can be reproduced, transformed to any other format, or distributed, without written permission by ITW Electronic Business Asia Co., Limited. 本文作為安達亞電器股份有限公司之智慧財產，非經許可不得擷取、複製、轉變成其他形式使用或散佈。</small>			DATE	REF: ---	<input checked="" type="checkbox"/> 管制文件 <input type="checkbox"/> 非管制文件	Unit mm	SCALE -	REV 1	RoHS Compliant	SHEET 2 OF 3