

4

3

2

1

PART NUMBER	REV	FIRST USED	TYPE
2369600-1	A	-	STANDARD

REVISIONS					
P	LTR	DESCRIPTION	DATE	DWN	APVD
	A	INITIAL RELEASE	6NOV20	CZ	

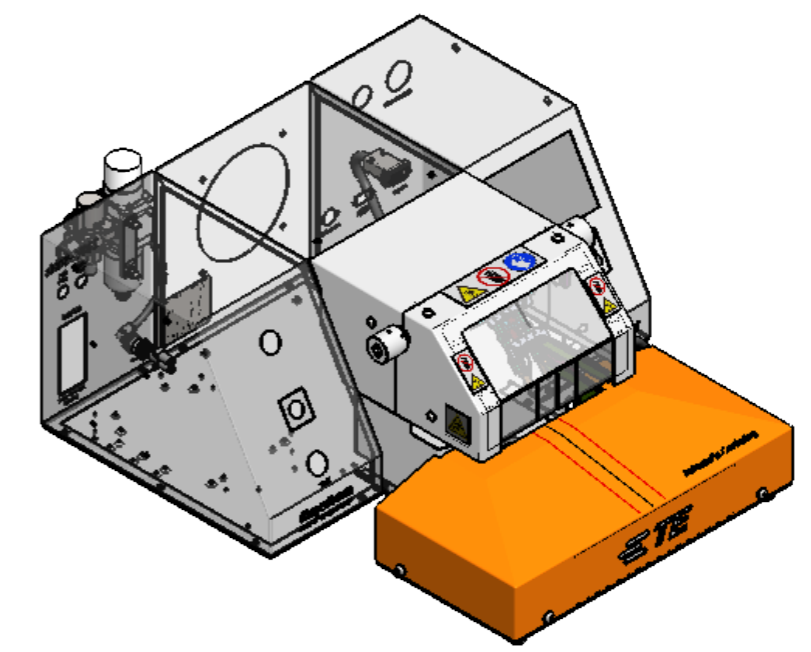
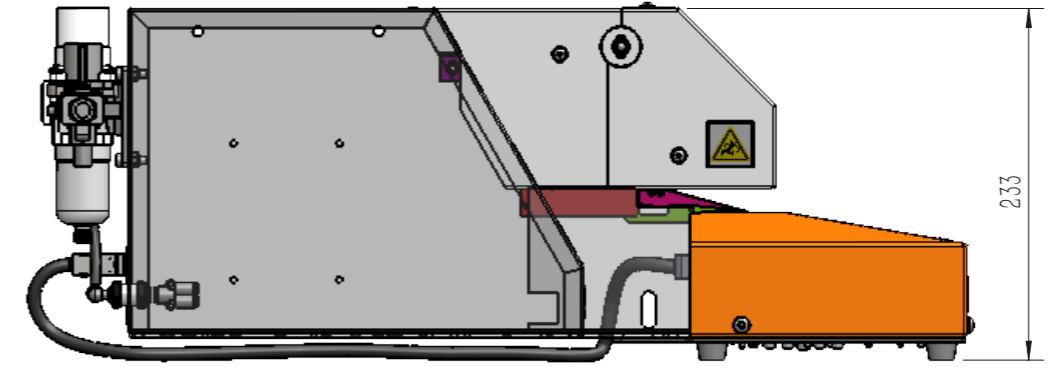
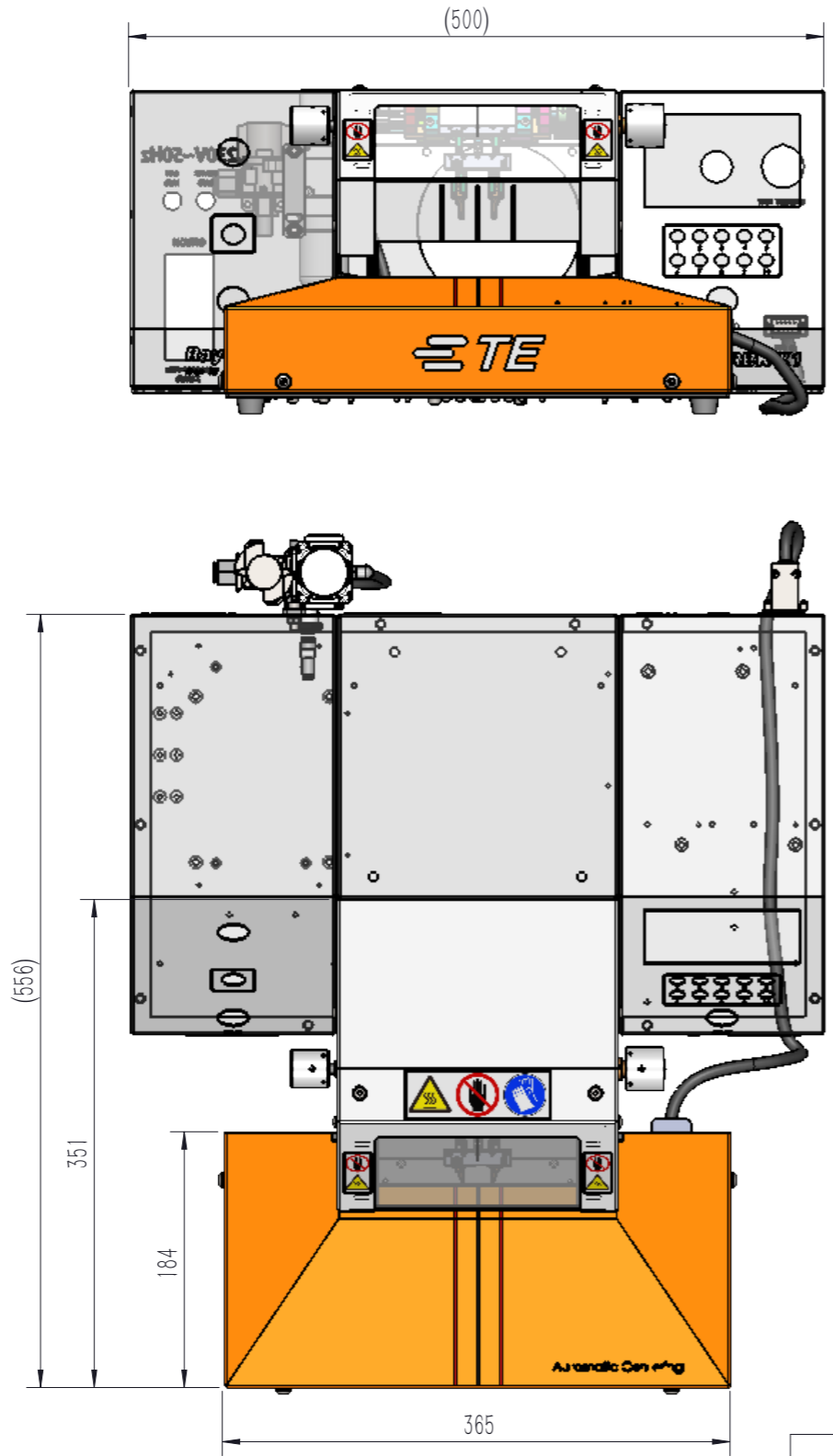

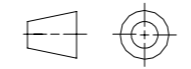
THIS DRAWING IS A CONTROLLED DOCUMENT.		DWN	C.ZHU	6NOV20	 <b>TE Connectivity</b>	
DIMENSIONS: mm		CHK				
		TOLERANCES UNLESS OTHERWISE SPECIFIED:		NAME		
MATERIAL		0 PLC	±	PRODUCT SPEC		
		1 PLC	±	SEE FIRST USED		
		2 PLC	±	APPLICATION SPEC		
		3 PLC	±	-		
		4 PLC	±	SIZE	CAGE CODE	DRAWING NO
		ANGLES	±	A3		C=2369600
		FINISH	-	RESTRICTED TO		
			-	CUSTOMER DRAWING		
			-	SCALE	1:5	SHEET 1 OF 3
			-	REV A		

C			
PART NUMBER	REV	FIRST USED	TYPE
2369600-1	A	-	STANDARD

REVISIONS					
P	LTR	DESCRIPTION	DATE	DWN	APVD
	A	INITIAL RELEASE	6NOV20	CZ	

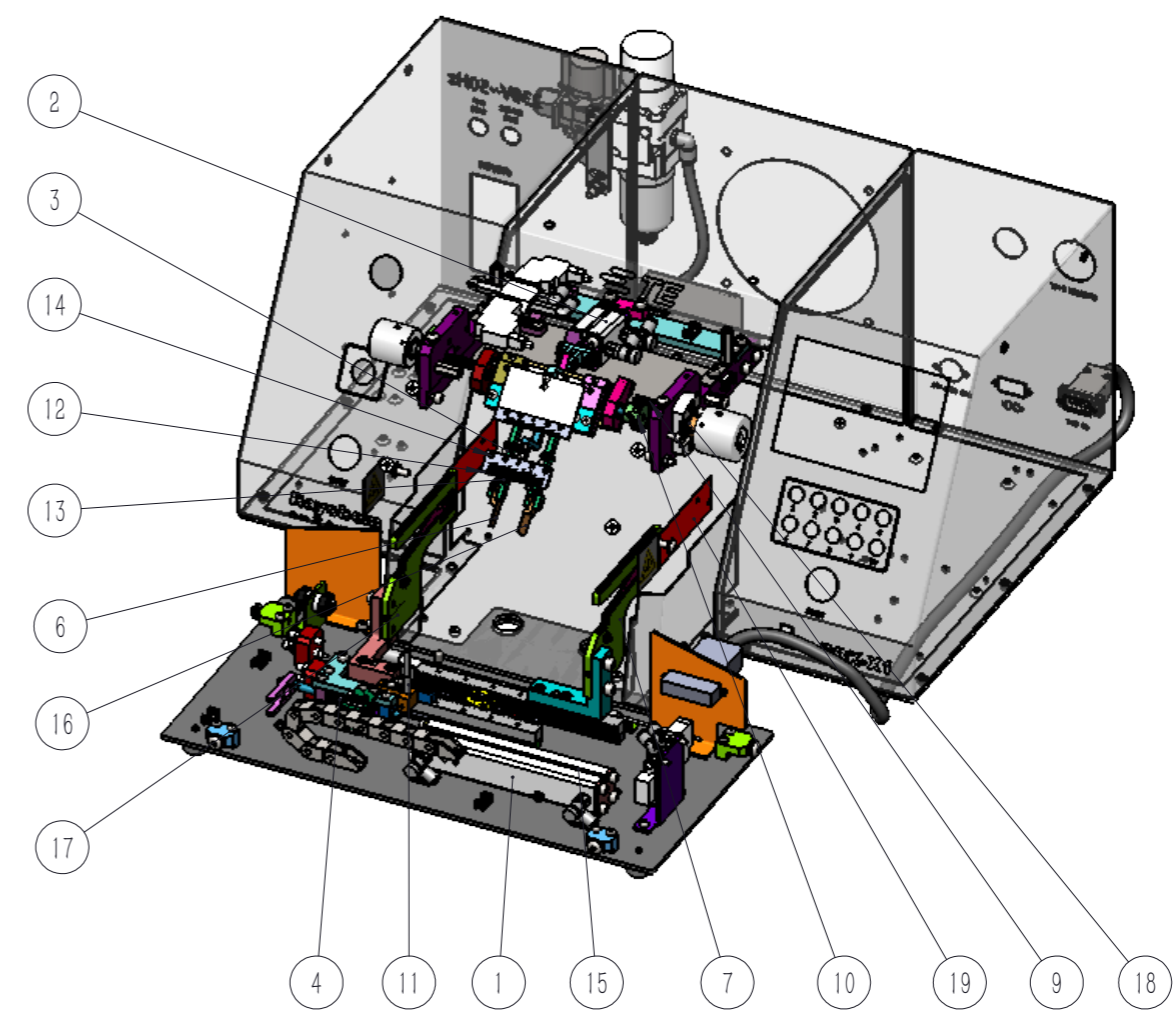
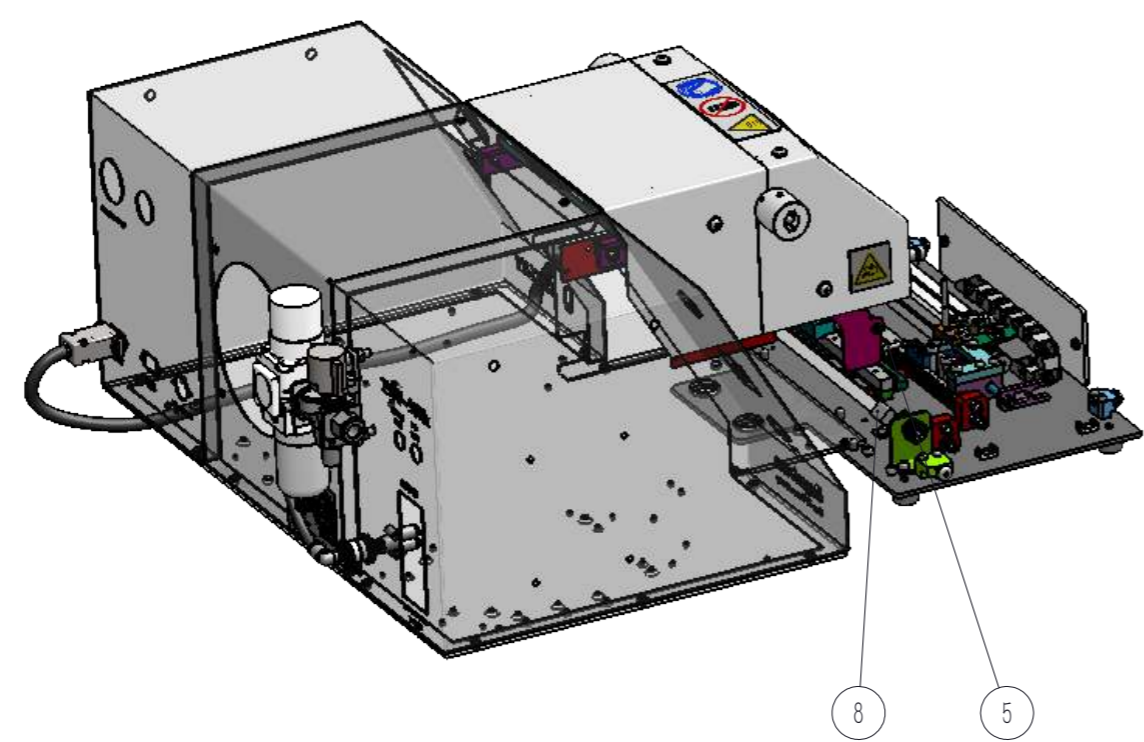

THIS DRAWING IS A CONTROLLED DOCUMENT.		DWN	C.ZHU	6NOV20				
DIMENSIONS: mm		CHK						NAME
		TOLERANCES UNLESS OTHERWISE SPECIFIED:		APVD		RBK-X1 CD HEAT SHRINK MACHINE		
MATERIAL		FINISH		PRODUCT SPEC		SIZE		
-		-		SEE FIRST USED		CAGE CODE		
-		-		APPLICATION SPEC		DRAWING NO		
				-		RESTRICTED TO		
				WEIGHT		A3		
				-		C=2369600		
				CUSTOMER DRAWING		SCALE 1:5		
						SHEET 2 OF 3		
						REV A		

C			
PART NUMBER	REV	FIRST USED	TYPE
2369600-1	A	-	STANDARD

REVISIONS				
P	LTR	DESCRIPTION	DATE	DWN
	A	INITIAL RELEASE	6NOV20	CZ

### SPARE PARTS LIST

ITEM NO	-1	TE/PN	DESCRIPTION
1	1	4-2369604-5	CYLINDER,DETECTION UNIT
2	1	6-2369604-7	CYLINDER,CENTERING UNIT
3	2	5-2369604-8	SPRING,DETECTION UNIT
4	1	4-2369604-3	SPRING,COMPERSS TUBE
5	2	4-2369604-2	SPRING,SWING PIIECE
6	1	3-2369602-1	DETECT PIECE
7	1	3-2369602-7	PLATE OF CENTER
8	1	3-2369604-5	LIGHT
9	1	7-2369602-1	MAIN DRIVE GEAR
10	1	5-2369602-7	DRIVEN GEAR
11	1	2-2369604-5	SENSOR,CENTER OFTUBE
12	1	8-2369602-1	MARK PLATE
13	2	2-2369603-4	POINTER
14	1	3-2369604-9	CALIBRATION LABEL
15	4	5-2369604-6	SENSOR,CYLINDER
16	1	6-2369602-5	DETECT PIECE<SEE 3-2369602-1>
17	1	6-2369602-2	PLATE OF CENTER<SEE 3-2369602-7>
18	1	7-2369604-9	O-ring
19	2	2-2369603-2	EJECTOR BLADE

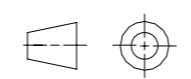
THIS DRAWING IS A CONTROLLED DOCUMENT.		DWN	C.ZHU	6NOV20	 TE Connectivity						
DIMENSIONS: mm		CHK						NAME <b>RBK-X1 CD HEAT SHRINK MACHINE</b>			
		TOLERANCES UNLESS OTHERWISE SPECIFIED:		APVD		PRODUCT SPEC SEE FIRST USED					
MATERIAL		FINISH		APPLICATION SPEC					SIZE <b>A3</b>		
-		-		-		CAGE CODE <b>C=2369600</b>					
-		-		WEIGHT		DRAWING NO <b>C=2369600</b>					
-		-		-		RESTRICTED TO					
CUSTOMER DRAWING				SCALE	1:5	SHEET	3	OF	3	REV	A