

1.2A/1A, Hysteretic, High Brightness LED Driver with Internal Switch

General Description

The RT8471 is a high efficiency, continuous mode inductive step-down converter, designed for driving single or multiple series connected LEDs from a voltage source higher than the LED voltage. It operates from an input voltage of 7V to 36V and employs hysteretic control with a high side current sense resistor to set the constant output current.

The RT8471 includes an output switch and a high side output current sensing circuit, which uses an external resistor to set the nominal average output current. LED brightness control is achieved with PWM dimming from an analog or PWM input signal.

The RT8471 is available in a small TSOT-23-5 package or a more thermal efficient SOP-8 (Exposed Pad) package.

Ordering Information

- RT8471 □ □
- Package Type
 - J5 : TSOT-23-5
 - SP : SOP-8 (Exposed Pad-Option 1)
 - Lead Plating System
 - G : Green (Halogen Free and Pb Free) (for TSOT-23-5 Only)
 - Z : ECO (Ecological Element with Halogen Free and Pb free) (for SOP-8 (Exposed Pad) Only)

Note :

Richtek products are :

- ▶ RoHS compliant and compatible with the current requirements of IPC/JEDEC J-STD-020.
- ▶ Suitable for use in SnPb or Pb-free soldering processes.

Marking Information

RT8471GJ5

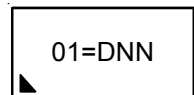

01= : Product Code
DNN : Date Code

RT8471ZSP

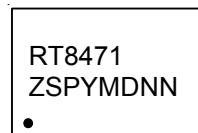

RT8471ZSP : Product Number
YMDNN : Date Code

Features

- 7V to 36V Input Voltage Range
- Hysteretic Control with High Side Current Sensing
- Internal N-MOSFET with 350mΩ Low R_{DS(ON)}
- 1A Output Current (For TSOT-23-5 Only)
- 1.2A Output Current (For SOP-8 (Exposed Pad) Only)
- Up to 97% Efficiency
- Typical ±5% LED Current Accuracy
- Analog or PWM Control Signal for LED Dimming
- 300Hz On-Board Ramp Generator
- Input Under Voltage Lockout
- Thermal Shutdown Protection
- RoHS Compliant and Halogen Free

Applications

- Automotive LED Lighting
- High Power LED Lighting
- Indicator and Emergency Lighting
- Architectural Lighting
- Low Voltage Industrial Lighting
- Signage and Decorative LED Lighting

Pin Configurations

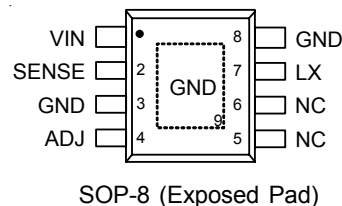
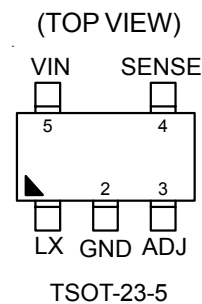

Typical Application Circuit

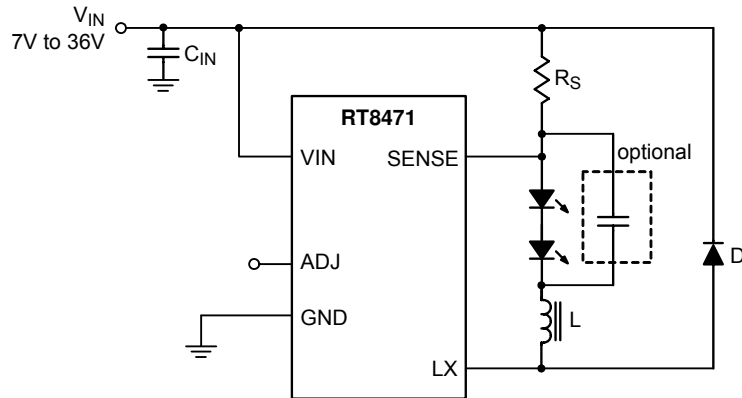

Functional Pin Description

| Pin No. | | Pin Name | Pin Function |
|-----------|--------------------------|----------|---|
| TSOT-23-5 | SOP-8 (Exposed Pad) | | |
| 1 | 7 | LX | Switch Output Terminal. Drain of internal N-MOSFET. |
| 2 | 3, 8, 9 (Exposed Pad) | GND | Ground. The exposed pad must be soldered to a large PCB and connected to GND for maximum power dissipation. |
| 3 | 4 | ADJ | Dimming Control Input : --- Analog signal input for analog PWM dimming. --- PWM signal input for digital PWM dimming. |
| 4 | 2 | SENSE | Output Current Sense. Sense LED string current with an external resistor connected between VIN and SENSE. |
| 5 | 1 | VIN | Supply Input Voltage. |
| - | 5, 6 | NC | No Internal Connection. |

Function Block Diagram

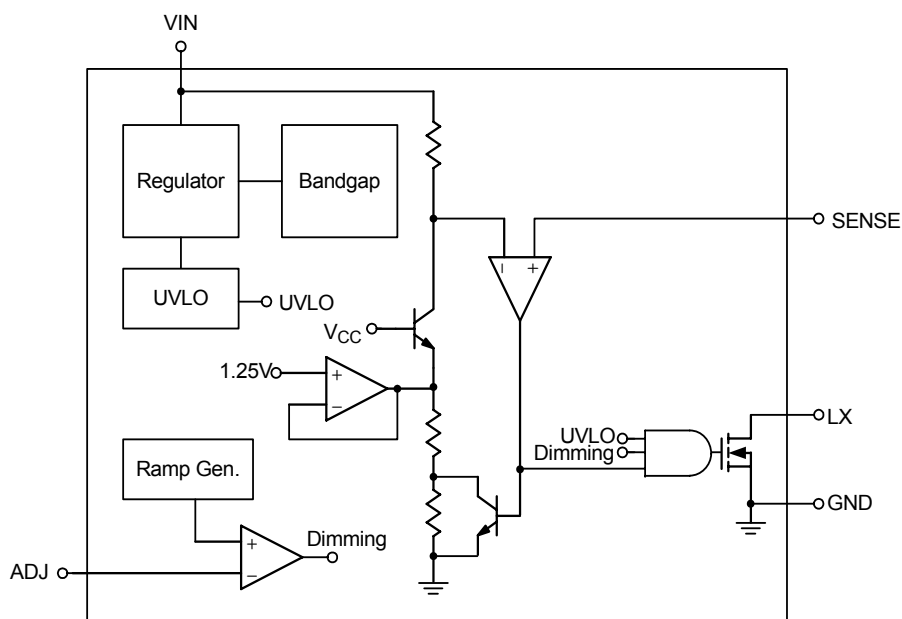

Absolute Maximum Ratings (Note 1)

- Supply Input Voltage, V_{IN} ----- -0.3V to 40V
- Switch Voltage, LX ----- -0.3V to ($V_{IN} + 0.7V$)
- Sense Voltage, SENSE ----- ($V_{IN} - 5V$) to ($V_{IN} + 0.3V$)
- All Other Pins ----- -0.3V to 6V
- Power Dissipation, P_D @ $T_A = 25^\circ C$
 - TSOT-23-5 (Single-layer PCB) ----- 0.400W
 - TSOT-23-5 (Four-layer PCB) ----- 0.625W
 - SOP-8 (Exposed pad) ----- 1.333W
- Package Thermal Resistance (Note 2)
 - TSOT-23-5, θ_{JA} (Single-layer PCB) ----- 250°C/W
 - TSOT-23-5, θ_{JA} (Four-layer PCB) ----- 160°C/W
 - TSOT-23-5, θ_{JC} (Single-layer PCB) ----- 130°C/W
 - SOP-8 (Exposed pad), θ_{JA} ----- 75°C/W
 - SOP-8 (Exposed pad), θ_{JC} ----- 15°C/W
- Junction Temperature ----- 150°C
- Lead Temperature (Soldering, 10 sec.) ----- 260°C
- Storage Temperature Range ----- -65°C to 150°C
- ESD Susceptibility (Note 3)
 - HBM (Human Body Mode) ----- 2kV
 - MM (Machine Mode) ----- 200V

Recommended Operating Conditions (Note 4)

- Supply Input Voltage, V_{IN} ----- 7V to 36V
- Junction Temperature Range ----- -40°C to 125°C

Electrical Characteristics

($V_{IN} = 12V$, $T_A = 25^\circ C$, unless otherwise specified)

| Parameter | Symbol | Test Conditions | Min | Typ | Max | Unit |
|--|--------------------|---|-----|------|-----|------|
| Mean Current Sense Threshold Voltage | V_{SENSE} | Measure on SENSE Pin with Respecting to V_{IN} . ADJ is Floating. | 95 | 100 | 105 | mV |
| Sense Threshold Hysteresis | ΔV_{SENSE} | | -- | ±15 | -- | % |
| Low Side Switch On-Resistance | $R_{DS(ON)}$ | | -- | 350 | 500 | mΩ |
| Low Side Switch Leakage Current | | $V_{LX} = 12V$, $V_{ADJ} = 0V$ | -- | 0.01 | 10 | μA |
| Under Voltage Lockout Threshold | V_{UVLO} | V_{IN} Rising | -- | 5.2 | -- | V |
| Under Voltage Lockout Threshold Hysteresis | ΔV_{UVLO} | | -- | 400 | -- | mV |
| Ramp Frequency | f_{RAMP} | | -- | 300 | -- | Hz |
| ADJ Input Threshold Voltage | Logic-High | $V_{ADJ, H}$ | 1.4 | -- | -- | V |
| | Logic-Low | $V_{ADJ, L}$ | -- | -- | 0.2 | |
| Analog Dimming Range | | | 0.3 | -- | 1.3 | V |
| Analog Dimming Threshold Voltage | Logic-High | | -- | 1.2 | 1.3 | V |
| | Logic-Low | | 0.3 | 0.4 | -- | |

To be continued

| Parameter | Symbol | Test Conditions | Min | Typ | Max | Unit |
|---|-----------------|--|-----|------|-----|-------------|
| Minimum Switch On-Time | $t_{ON(MIN)}$ | LX Switch On | -- | 210 | -- | ns |
| Minimum Switch Off-Time | $t_{OFF(MIN)}$ | LX Switch Off | -- | 170 | -- | ns |
| Quiescent Input Current with Output Off | $I_{VIN, Off}$ | $V_{ADJ} = 0V$ | -- | 450 | -- | μA |
| Quiescent Input Current with Output Switching | $I_{VIN, On}$ | ADJ is Floating, $f_{SW} = 250kHz$, $V_{IN} = 8V$ | -- | 1000 | -- | μA |
| Internal Propagation Delay | t_{PD} | | -- | 25 | -- | ns |
| Sense Pin Input Current | I_{SENSE} | $V_{SENSE} = V_{IN} - 0.1V$ | -- | 300 | -- | nA |
| Thermal Shutdown | T_{SD} | | -- | 150 | -- | $^{\circ}C$ |
| Thermal Shutdown Hysteresis | ΔT_{SD} | | -- | 30 | -- | $^{\circ}C$ |

Note 1. Stresses listed as the above "Absolute Maximum Ratings" may cause permanent damage to the device. These are for stress ratings. Functional operation of the device at these or any other conditions beyond those indicated in the operational sections of the specifications is not implied. Exposure to absolute maximum rating conditions for extended periods may remain possibility to affect device reliability.

Note 2. θ_{JA} is measured in natural convection at $T_A = 25^{\circ}C$ on a single-layer and four-layer test board of JEDEC 51 thermal measurement standard. For SOP-8 (Exposed Pad) the measurement case position of θ_{JC} is on the exposed pad of the package. For TSOT-23-5, the measurement case position of θ_{JC} is on the lead of the package.

Note 3. Devices are ESD sensitive. Handling precaution is recommended.

Note 4. The device is not guaranteed to function outside its operating conditions.

Typical Operating Characteristics

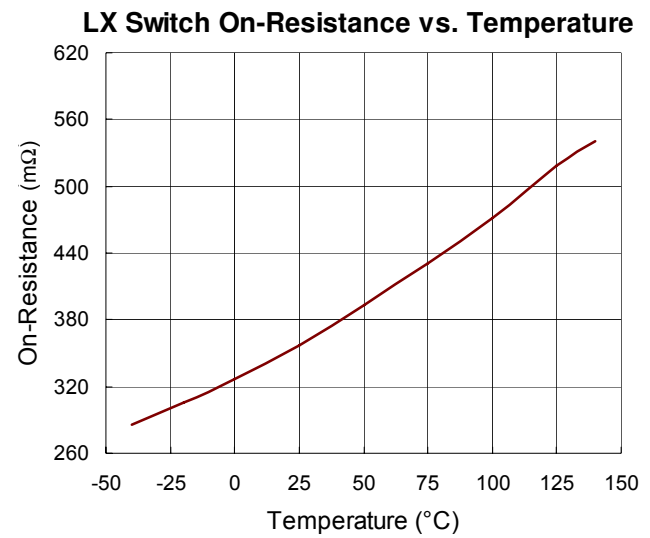
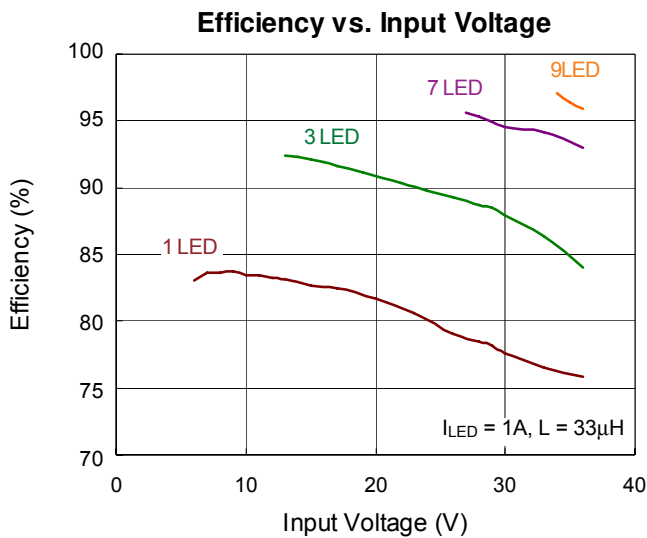
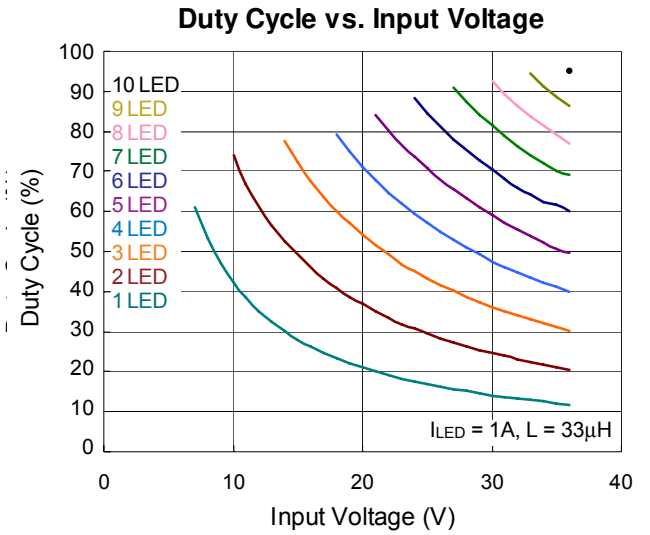
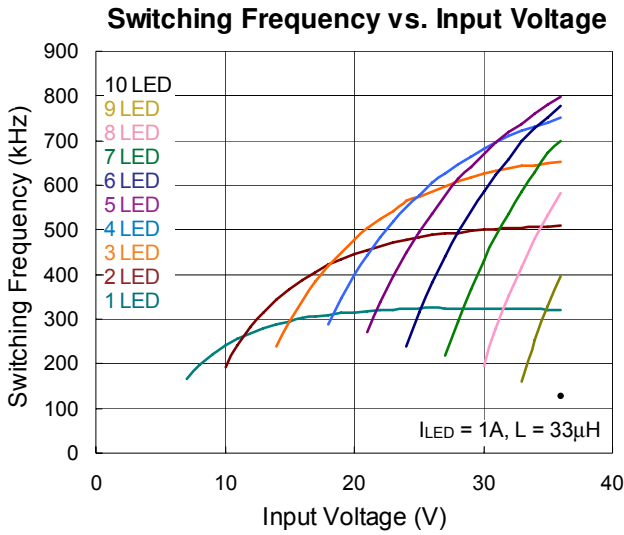
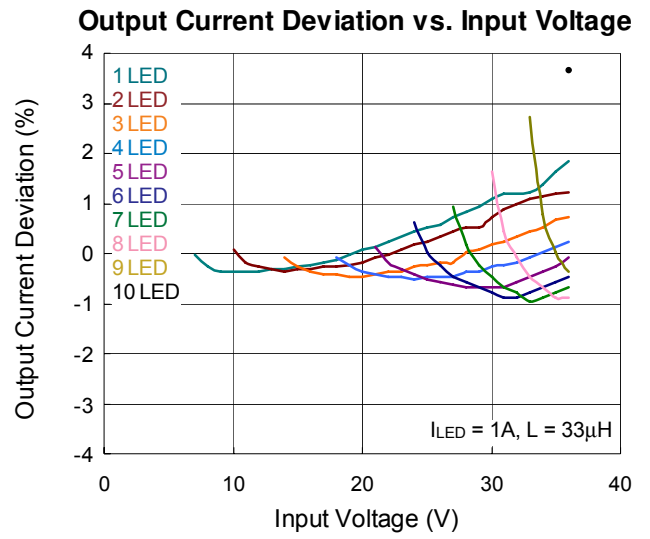
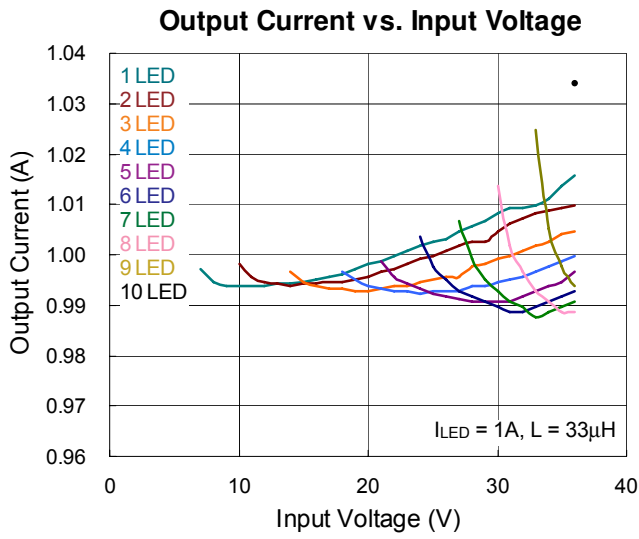

Quiescent Input Current vs. Input Voltage

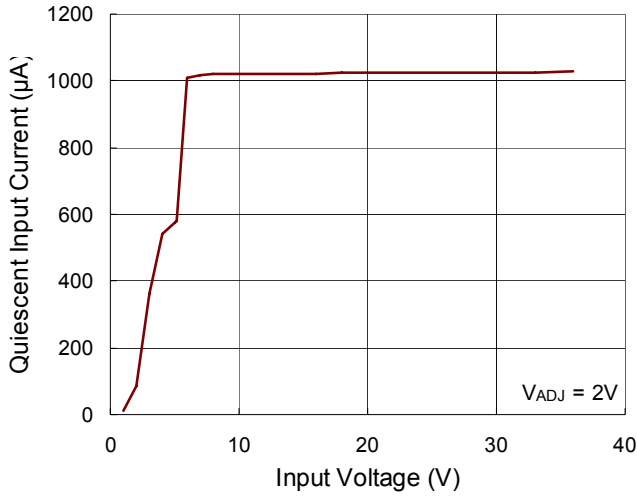

Quiescent Input Current vs. Input Voltage

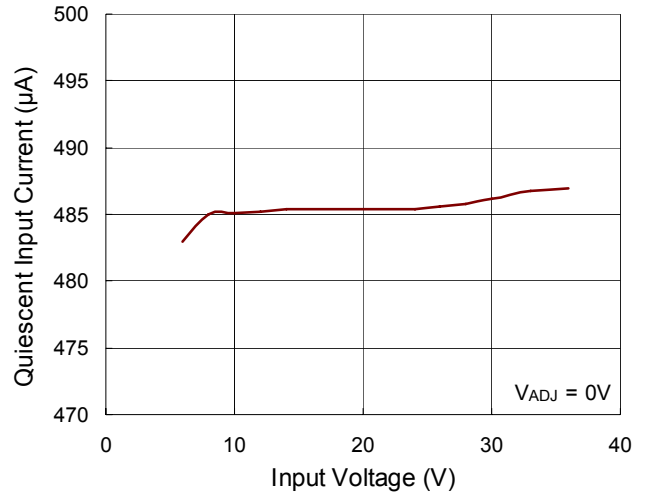

Output Current vs. PWM Duty Cycle

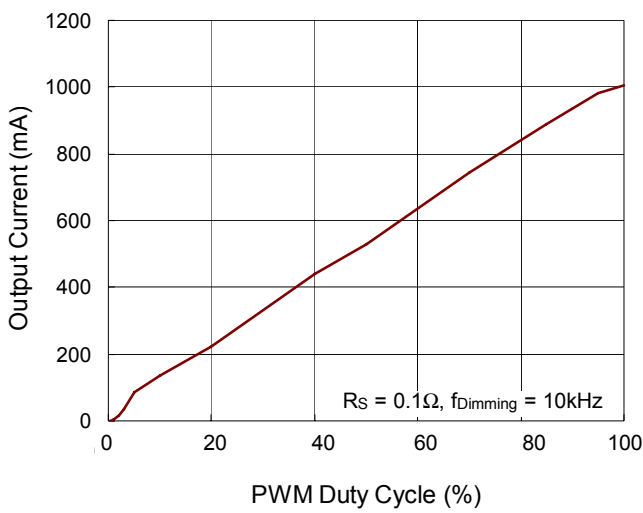

Output Current vs. PWM Duty Cycle

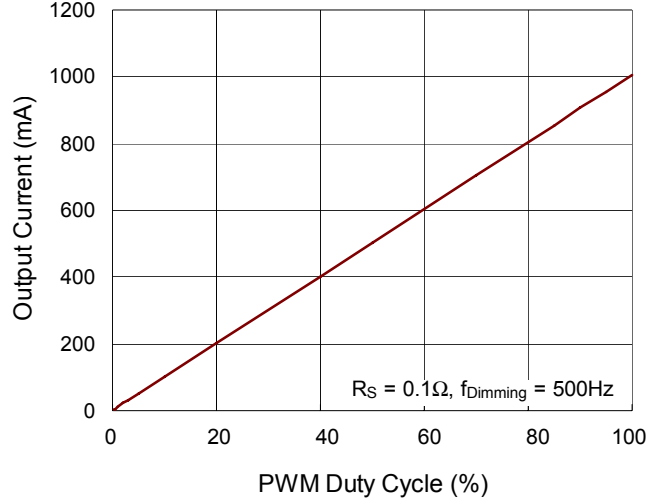

Output Current vs. ADJ Voltage

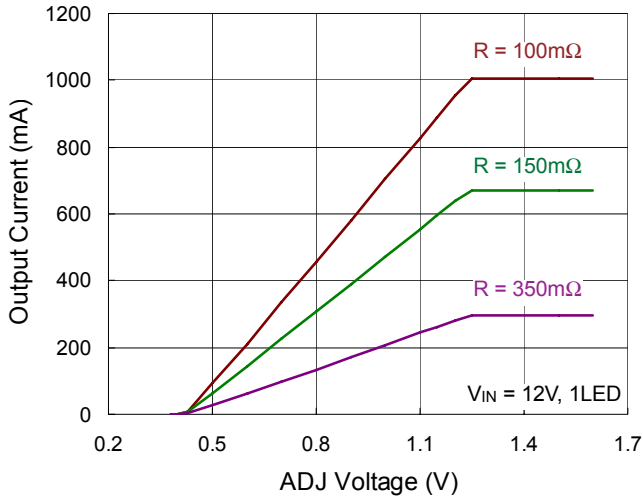

Ramp Frequency vs. Temperature

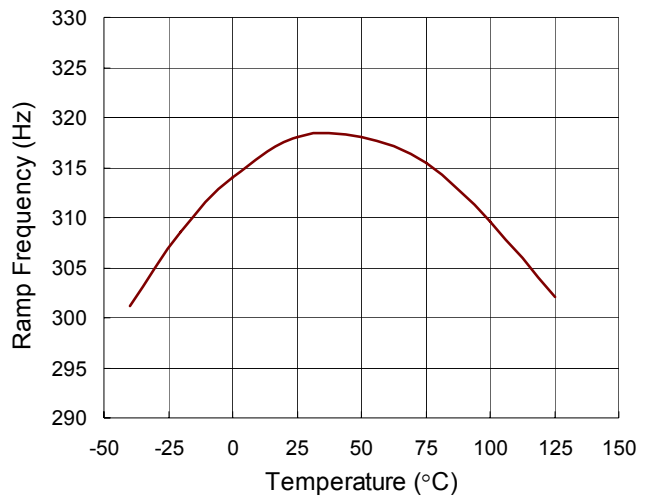

Digital Dimming from ADJ On

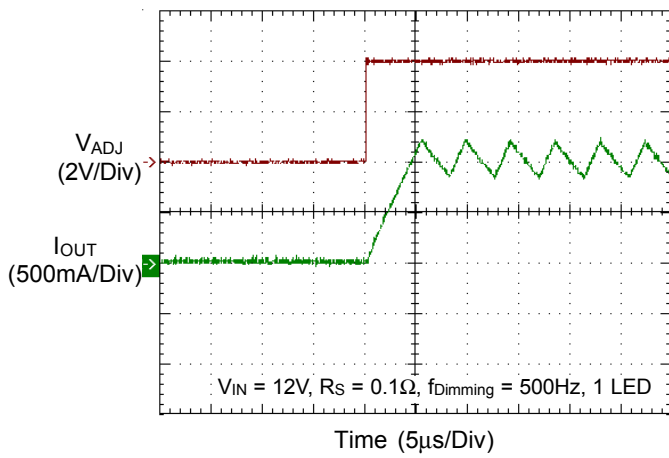

Digital Dimming from ADJ Off

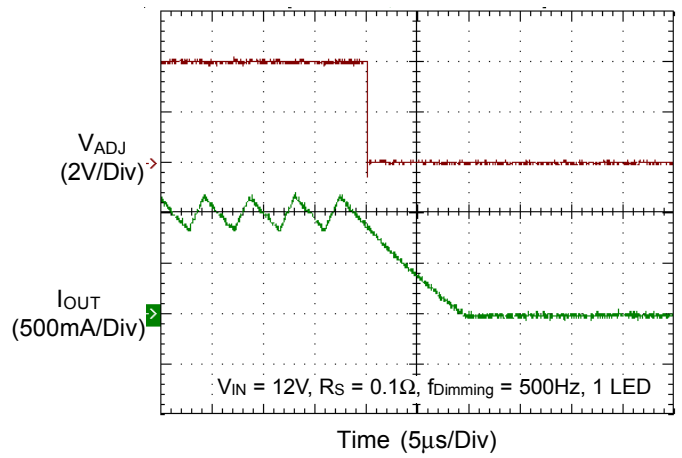

Power On from VIN

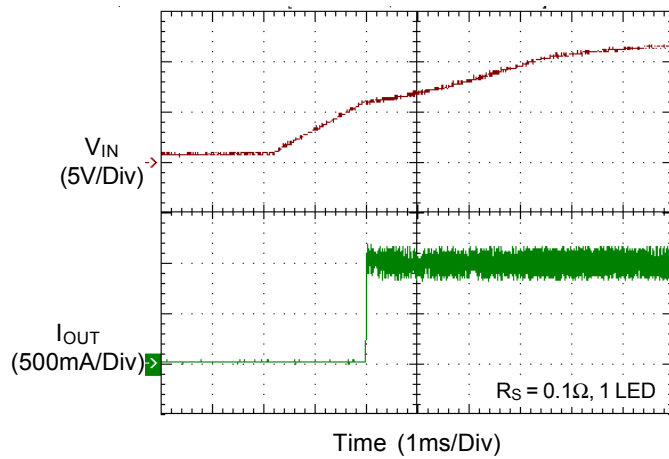

Power Off from VIN

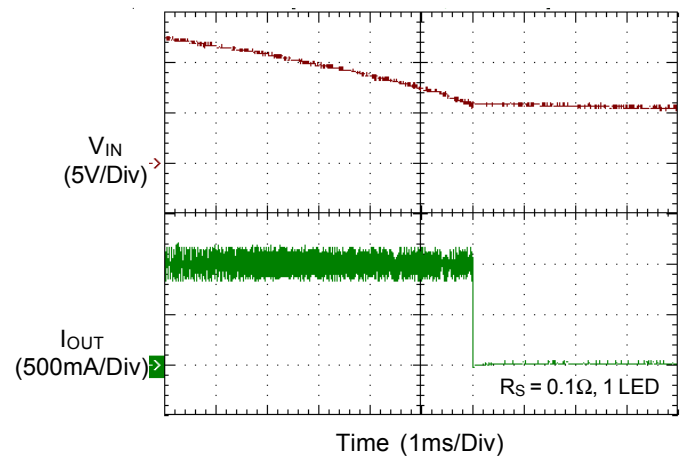

Application Information

The RT8471 is a simple high efficiency, continuous mode inductive step-down converter. The device operates with an input voltage range from 7V to 36V and delivers up to 1.2A of output current. A high side current sense resistor sets the output current. A dedicated PWM dimming input enables pulsed LED dimming over a wide range of brightness levels. A high side current sensing scheme and an onboard current setting circuitry minimize the number of external components. A 1% sense resistor performs a ±5% LED current accuracy for the best performance.

Under Voltage Lockout (UVLO)

The RT8471 includes a UVLO feature with 400mV hysteresis. The internal MOSFET turns off when V_{IN} falls below 4.8V (typ.).

Setting Average Output Current

The RT8471 output current which flows through the LEDs is set by an external resistor (R_S) connected between the VIN and SENSE terminal. The relationship between output current (I_{OUT}) and R_S is shown as below :

$$I_{OUTavg} = \frac{0.1V}{R_S} \quad (A)$$

Analog Dimming Control

The ADJ terminal can be driven by an external voltage (V_{ADJ}) to adjust the average output current. The average output current is given by :

$$I_{OUTavg} = \left(\frac{0.1V}{R_S} \right) \times \frac{V_{ADJ} - 0.4}{0.8}$$

where V_{ADJ} is ranged from 0.4V to 1.2V. When V_{ADJ} is larger than 1.2V, the output current value will only depend on the external resistor (R_S).

Digital Dimming Control

A Pulse Width Modulated (PWM) signal can drive the ADJ terminal directly. Notice that the PWM signal logic high level must be above 1.4V and the logic low level must be below 0.2V at the ADJ terminal. It's recommended to maintain the PWM dimming at low frequency (ex. 500Hz) in order to obtain a linear dimming curve.

PWM Soft-Start Behavior

The RT8471 features an optional PWM soft-start behavior that allows for gradual brightness transition. This is achieved by simply connecting an external capacitor between the ADJ pin and GND. An internal current source will then charge this capacitor for soft-start behavior, resulting in steady LED current increase and decrease during power on and power off, as shown in Figure 1.

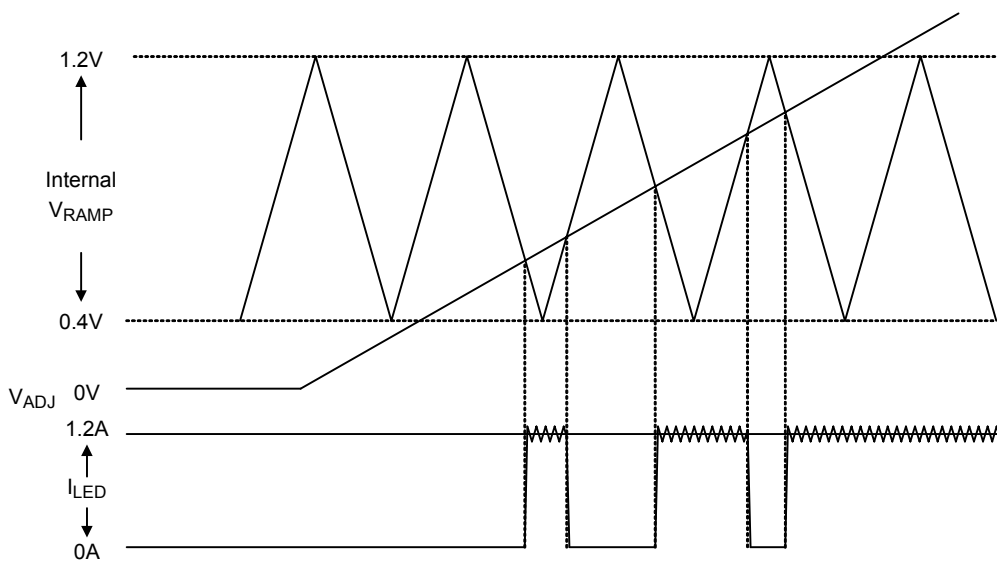

Figure 1. PWM Soft-Start Behavior Mechanism

The capacitor can be selected according to below equation :

$$C = 1.5 \times 10^{-6} \times t_{SS}$$

where t_{SS} is the soft-start period.

LED Current Ripple Reduction

Higher LED current ripple will shorten the LED life time and increase heat accumulation of LED. There are two ways to reduce the LED current ripple. One way is by increasing the inductance to lower LED current ripple in absence of an output capacitor. The other way is by adding an output capacitor in parallel with the LED. This will then allow the use of a smaller inductor.

Inductor Selection

The inductance is determined by inductor current ripple, switching frequency, duty ratio, circuit specifications and component parameters, as expressed in the following equation :

$$L > \left[V_{IN} - V_{OUT} - V_{SEN} - (R_{DS(ON)} \times I_{OUT}) \right] \times \frac{D}{f_{SW} \times \Delta I_L}$$

where

f_{SW} is the switching frequency (Hz)

$R_{DS(ON)}$ is the low side switch on-resistance of internal MOSFET (= 0.35Ω typical)

D is the duty cycle determined by V_{OUT}/V_{IN}

I_{OUT} is the required LED current (A)

ΔI_L is the inductor peak-peak ripple current (internally set to $0.3 \times I_{OUT}$)

V_{IN} is the input supply voltage (V)

V_{OUT} is the total LED forward voltage (V)

Besides, the selected inductance has also to satisfy the limit of the minimum switch on/off time. The calculated on time must be greater than 210ns of the minimum on time, and the off time must be greater than 170ns of the minimum off time. The following equation can be used to verify the suitability of the inductor value.

$$t_{ON} = \frac{L \times \Delta I_L}{V_{IN} - V_{OUT} - I_{OUT} (R_{SEN} + R_L + R_{DS(ON)})}$$

$> t_{ON(MIN)}(210ns \text{ typ.})$

$$t_{OFF} = \frac{L \times \Delta I_L}{V_{OUT} + V_D + V_{SEN} + (I_{OUT} \times R_L)}$$

$> t_{OFF(MIN)}(170ns \text{ typ.})$

where

V_D is the rectifier diode forward voltage (V)

V_{SEN} is the voltage cross current sense resistor (V)

R_L is the inductor DC resistance (Ω)

L is the inductance (H)

The saturation current of the selected inductor must be higher than the peak output LED current, and the continuous current rating must be above the average output LED current. In general, the inductor saturation current should be 1.5 times the LED current. In order to reduce the output current ripple, a higher inductance is recommended at higher supply voltages. However, it could also cause a higher line resistance and result in a lower efficiency.

Diode selection

To obtain better efficiency, the Schottky diode is recommended for its low reverse leakage current, low recovery time and low forward voltage. With its low power dissipation, the Schottky diode outperforms other silicon diodes and increase overall efficiency.

Input Capacitor selection

Input capacitor has to supply peak current to the inductor and flatten the current ripple on the input. The low ESR condition is required to avoid increasing power loss. The ceramic capacitor is recommended due to its excellent high frequency characteristic and low ESR, which are suitable for the RT8471. For maximum stability over the entire operating temperature range, capacitors with better dielectric are suggested.

Thermal Protection

A thermal protection feature is included to protect the RT8471 from excessive heat damage. When the junction temperature exceeds a threshold of 150°C, the thermal protection will turn off the LX terminal. When the junction temperature drops below 120°C, the RT8471 will turn back on the LX terminal and return to normal operations.

Thermal Considerations

For continuous operation, do not exceed absolute maximum junction temperature. The maximum power dissipation depends on the thermal resistance of the IC package, PCB layout, rate of surrounding airflow, and difference between junction and ambient temperature. The maximum power dissipation can be calculated by the following formula :

$$P_{D(MAX)} = (T_{J(MAX)} - T_A) / \theta_{JA}$$

where $T_{J(MAX)}$ is the maximum junction temperature, T_A is the ambient temperature, and θ_{JA} is the junction to ambient thermal resistance.

For recommended operating condition specifications of the RT8471, the maximum junction temperature is 125°C and T_A is the ambient temperature. The junction to ambient thermal resistance, θ_{JA} , is layout dependent. For TSOT-23-5 packages, the thermal resistance, θ_{JA} , is 250°C/W on a standard JEDEC 51-3 single-layer thermal test board and 160°C/W on a standard JEDEC 51-7 four-layer thermal test board. For SOP-8 (Exposed pad) package, the thermal resistance, θ_{JA} , is 75°C/W on a standard JEDEC 51-7 four-layer thermal test board. The maximum power dissipation at $T_A = 25^\circ\text{C}$ can be calculated by the following formulas :

$$P_{D(MAX)} = (125^\circ\text{C} - 25^\circ\text{C}) / (250^\circ\text{C/W}) = 0.4\text{W for TSOT-23-5 package (single-layer PCB)}$$

$$P_{D(MAX)} = (125^\circ\text{C} - 25^\circ\text{C}) / (160^\circ\text{C/W}) = 0.625\text{W for TSOT-23-5 package (four-layer PCB)}$$

$$P_{D(MAX)} = (125^\circ\text{C} - 25^\circ\text{C}) / (75^\circ\text{C/W}) = 1.333\text{W for SOP-8 (Exposed pad) package}$$

The maximum power dissipation depends on the operating ambient temperature for fixed $T_{J(MAX)}$ and thermal resistance, θ_{JA} . For the RT8471 packages, the derating curves in Figure 2 allow the designer to see the effect of rising ambient temperature on the maximum power dissipation.

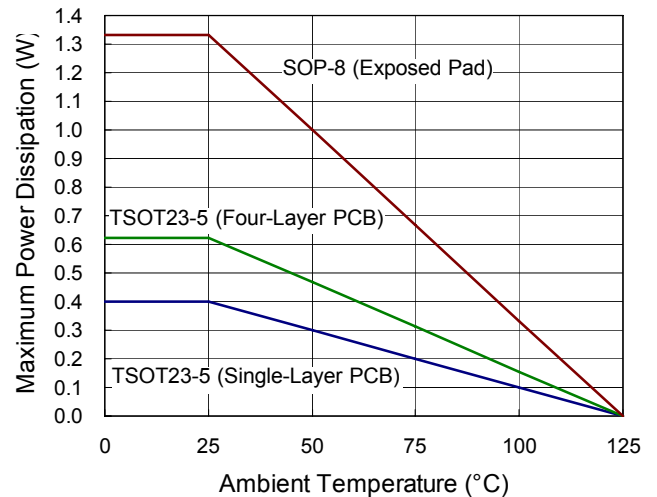

Figure 2. Derating Curve for Packages

Layout Considerations

For best performance of the RT8471, please abide the following layout guide.

- ▶ The capacitor C_{IN} , C_{ADJ} and external resistor, R_S , must be placed as close as possible to the VIN and SENSE pins of the device respectively.
- ▶ The GND should be connected to a strong ground plane.
- ▶ Keep the main current traces as short and wide as possible.
- ▶ The inductor (L) should be mounted as close to the device with low resistance connections.
- ▶ The ADJ pin trace need to be kept far away from LX terminal.

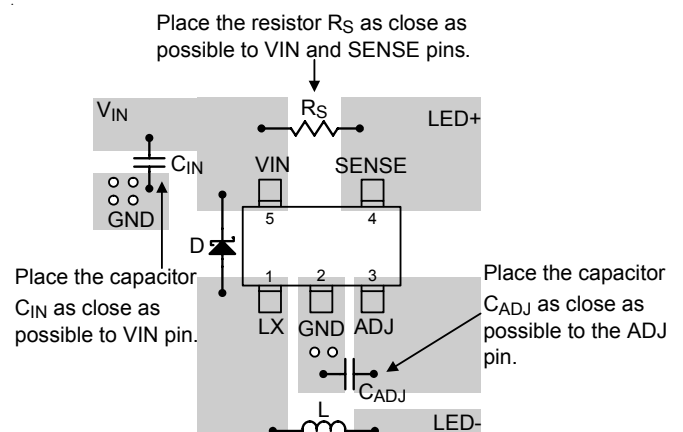
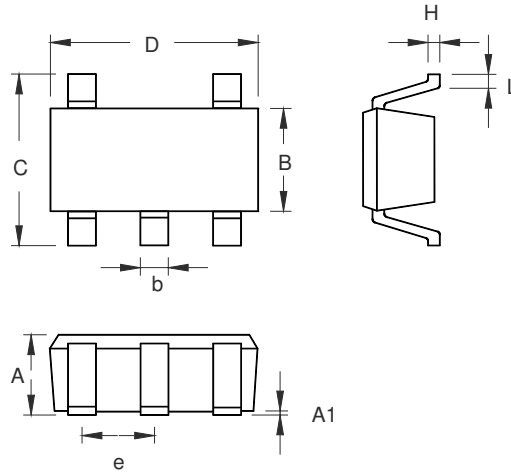

Figure 3. PCB Layout Guide

Outline Dimension



| Symbol | Dimensions In Millimeters | | Dimensions In Inches | |
|--------|---------------------------|-------|----------------------|-------|
| | Min | Max | Min | Max |
| A | 0.700 | 1.000 | 0.028 | 0.039 |
| A1 | 0.000 | 0.100 | 0.000 | 0.004 |
| B | 1.397 | 1.803 | 0.055 | 0.071 |
| b | 0.300 | 0.559 | 0.012 | 0.022 |
| C | 2.591 | 3.000 | 0.102 | 0.118 |
| D | 2.692 | 3.099 | 0.106 | 0.122 |
| e | 0.838 | 1.041 | 0.033 | 0.041 |
| H | 0.080 | 0.254 | 0.003 | 0.010 |
| L | 0.300 | 0.610 | 0.012 | 0.024 |

TSOT-23-5 Surface Mount Package

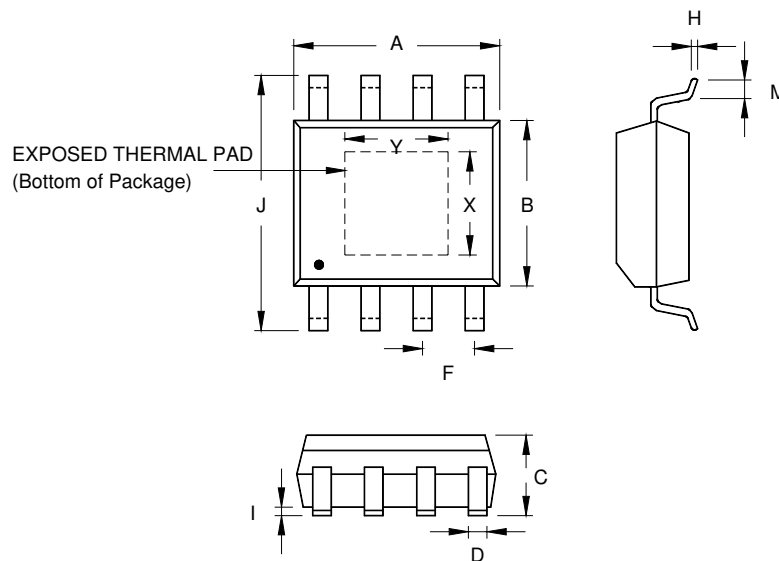

| Symbol | Dimensions In Millimeters | | Dimensions In Inches | | |
|----------|---------------------------|-------|----------------------|-------|-------|
| | Min | Max | Min | Max | |
| A | 4.801 | 5.004 | 0.189 | 0.197 | |
| B | 3.810 | 4.000 | 0.150 | 0.157 | |
| C | 1.346 | 1.753 | 0.053 | 0.069 | |
| D | 0.330 | 0.510 | 0.013 | 0.020 | |
| F | 1.194 | 1.346 | 0.047 | 0.053 | |
| H | 0.170 | 0.254 | 0.007 | 0.010 | |
| I | 0.000 | 0.152 | 0.000 | 0.006 | |
| J | 5.791 | 6.200 | 0.228 | 0.244 | |
| M | 0.406 | 1.270 | 0.016 | 0.050 | |
| Option 1 | X | 2.000 | 2.300 | 0.079 | 0.091 |
| | Y | 2.000 | 2.300 | 0.079 | 0.091 |
| Option 2 | X | 2.100 | 2.500 | 0.083 | 0.098 |
| | Y | 3.000 | 3.500 | 0.118 | 0.138 |

8-Lead SOP (Exposed Pad) Plastic Package

Richtek Technology Corporation

Headquarter
 5F, No. 20, Taiyuen Street, Chupei City
 Hsinchu, Taiwan, R.O.C.
 Tel: (8863)5526789 Fax: (8863)5526611

Richtek Technology Corporation

Taipei Office (Marketing)
 5F, No. 95, Minchiuan Road, Hsintien City
 Taipei County, Taiwan, R.O.C.
 Tel: (8862)86672399 Fax: (8862)86672377
 Email: marketing@richtek.com

Information that is provided by Richtek Technology Corporation is believed to be accurate and reliable. Richtek reserves the right to make any change in circuit design, specification or other related things if necessary without notice at any time. No third party intellectual property infringement of the applications should be guaranteed by users when integrating Richtek products into any application. No legal responsibility for any said applications is assumed by Richtek.