

BR5000W - BR5010W

SILICON BRIDGE RECTIFIERS

PRV : 50 - 1000 Volts
Io : 50 Amperes

FEATURES :

- * High current capability
- * High surge current capability
- * High reliability
- * Low reverse current
- * Low forward voltage drop
- * High case dielectric strength
- * **Pb / RoHS Free**

MECHANICAL DATA :

- * Case : Molded plastic with heatsink integrally mounted in the bridge encapsulation
- * Epoxy : UL94V-O rate flame retardant
- * Terminals : Plated lead solderable per MIL-STD-202, Method 208 guaranteed
- * Polarity : Polarity symbols marked on case
- * Mounting position : Bolt down on heat-sink with silicone thermal compound between bridge and mounting surface for maximum heat transfer efficiency
- * Weight : 15.95 grams

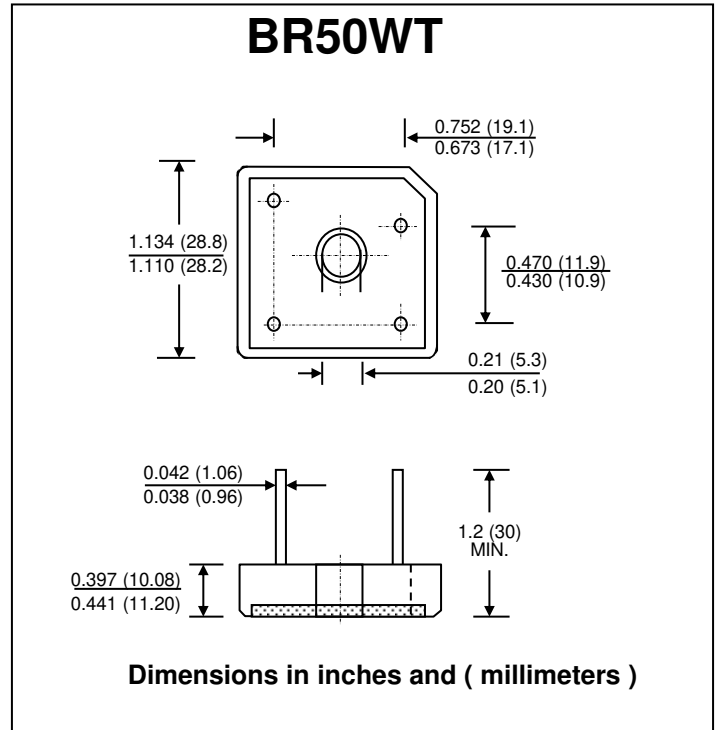

MAXIMUM RATINGS AND ELECTRICAL CHARACTERISTICS

Rating at 25 °C ambient temperature unless otherwise specified.
 Single phase, half wave, 60 Hz, resistive or inductive load.
 For capacitive load, derate current by 20%.

RATING	SYMBOL	BR 5000W	BR 5001W	BR 5002W	BR 5004W	BR 5006W	BR 5008W	BR 5010W	UNIT
Maximum Recurrent Peak Reverse Voltage	VRRM	50	100	200	400	600	800	1000	V
Maximum RMS Voltage	VRMS	35	70	140	280	420	560	700	V
Maximum DC Blocking Voltage	VDC	50	100	200	400	600	800	1000	V
Maximum Average Forward Current Tc=55°C	IF(AV)	50							A
Peak Forward Surge Current Single half sine wave Superimposed on rated load (JEDEC Method)	IFSM	400							A
Current Squared Time at t < 8.3 ms.	I ² t	664							A ² S
Maximum Forward Voltage per Diode at IF = 25 A	VF	1.1							V
Maximum DC Reverse Current Ta = 25 °C at Rated DC Blocking Voltage Ta = 100 °C	IR	10							µA
	IR(H)	200							µA
Typical Thermal Resistance at Junction to Case (Note 1)	RθJC	1.0							°C/W
Operating Junction Temperature Range	TJ	- 40 to + 150							°C
Storage Temperature Range	TSTG	- 40 to + 150							°C

Note :

1) Thermal resistance from Junction to Case with units mounted on heat sink.

RATING AND CHARACTERISTIC CURVES (BR5000W - BR5010W)

FIG.1 - DERATING CURVE FOR OUTPUT RECTIFIED CURRENT

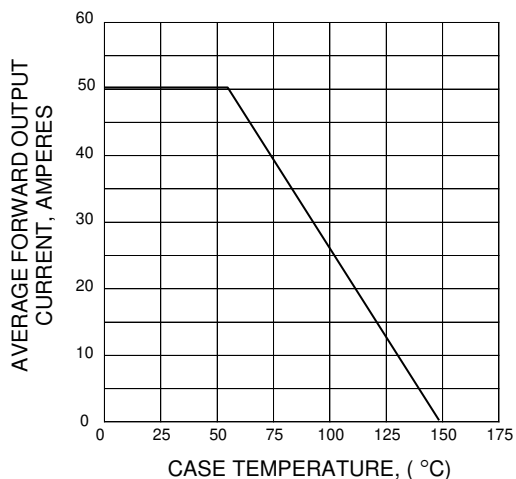

FIG.2 - MAXIMUM NON-REPETITIVE PEAK FORWARD SURGE CURRENT

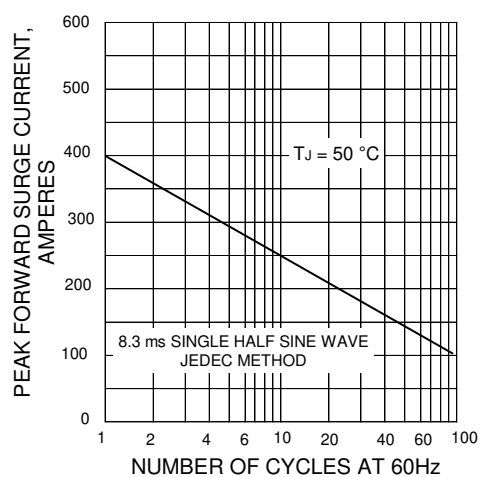

FIG.3 - TYPICAL FORWARD CHARACTERISTICS PER DIODE

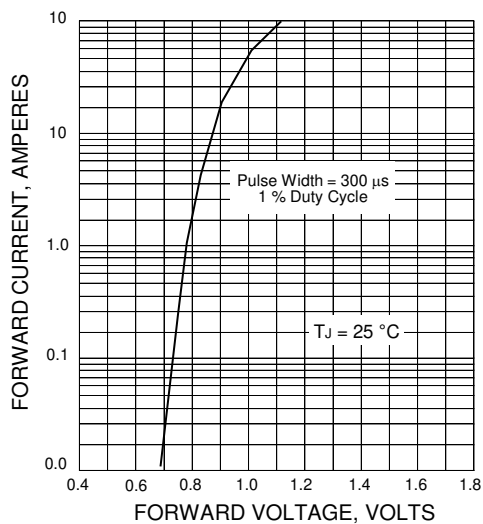

FIG.4 - TYPICAL REVERSE CHARACTERISTICS PER DIODE

