

# FW60 series

# 60 Watt AC Adapter

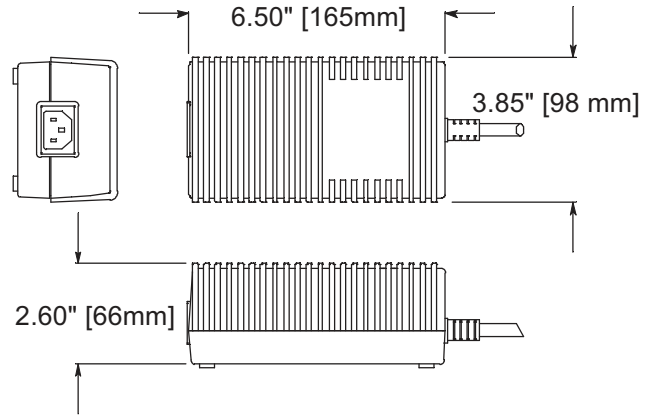

### Features

- Wide range AC input
- Fully regulated output
- High efficiency
- 5 year warranty
- RoHS compliant version available

### Environmental

- Operating temperature..... 0° C to 40° C
- Storage temperature..... -55° C to 85° C
- Weight = 2.5 lbs

### EMI/EMC

Meets FCC class B, CISPR 22 class B

### Safety

- CSA Certified to CSA 950
- NRTL/C : UL 1950, CSA 950
- CE Marked

Polarity	1	2	3	4	5
DIN-5	Com	Com	+V	Com	+V

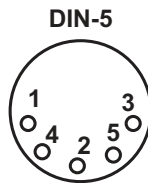

### Ordering Information

- FW = Series
- 60 = Watts DC Output
- XX = Voltage DC Output
- D5 = Output Connector (options available)
- F = RoHS Compliant
- NC = No AC input Cord (options available)

### Electrical Specifications

#### Input

- Voltage..... 100 - 240 VAC
- Current..... 2.0 Amp @ 100 VAC
- Frequency..... 47 - 63 Hz
- AC cord..... Optional
- Input connector..... 3 Pin IEC 320 input receptacle

#### Output

- Line regulation..... TYP +/- 1%
- Load regulation..... TYP +/- 5%
- Set point..... +/- 3% at 60% load
- Hold up time..... 20 ms min at full load, 115 VAC
- Over voltage protection..... Built-in
- Over current protection..... Built-in
- Short circuit protection..... Pulsing mode, auto recovery
- Efficiency..... 80% min at full load and 115 VAC
- Transient response..... 2 ms for 50% load change typical
- Ripple/noise (V<sub>p-p</sub>)..... +/- 1% (20 MHz bandwidth)
- Output connector..... 5 pin DIN

Model No.	Voltage	Power	Current
FW6012-D5-NC	12V	60W	5.0A
FW6012-D5F-NC			
FW6024-D5-NC	24V	60W	2.5A
FW6024-D5F-NC			