

REVISION HISTORY			
REV	DESCRIPTION	DATE	APPROVED
-	DCN 35555	12/07	STW
A	DCN 38375	07/11	STW

PRODUCT DATA DRAWING

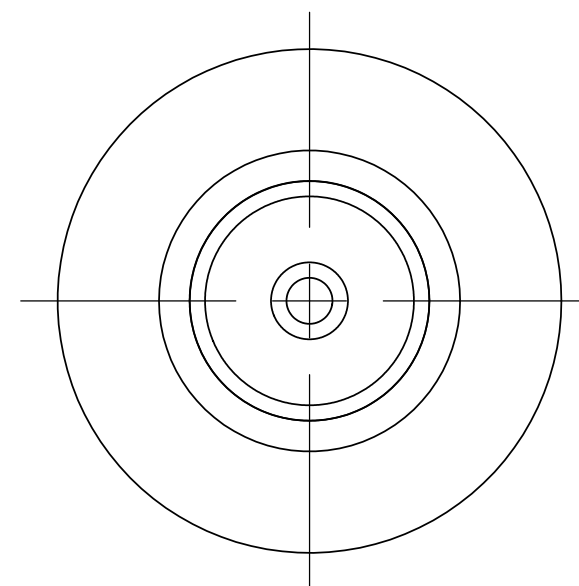
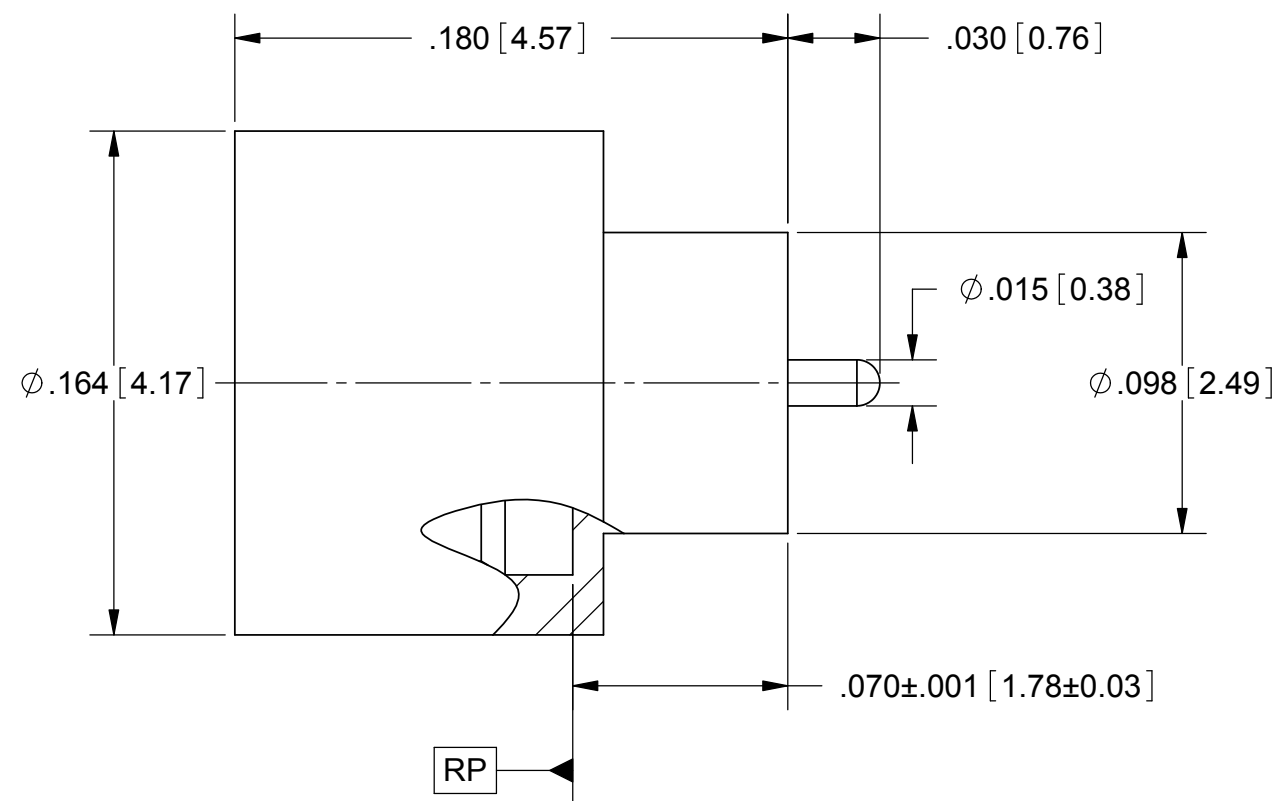

MATERIAL:

BODY & PIN: KOVAR PER ASTM F15

GLASS: 7070

FINISH:

BODY & PIN: GOLD PER ASTM B 488, TYPE II, CODE C, CLASS 1.27; OVER NICKEL PER AMS-QQ-N-290, CLASS 1, .00005" MIN.

PERFORMANCE:

IMPEDANCE: 50 OHMS
 FREQ. RANGE: DC TO 26.5 GHz
 VSWR: 1.25:1 DC TO 18.0 GHz
 1.35:1 DC TO 26.5 GHz

DWV: 500 VRMS
 OPERATING TEMP.: -55°C TO +165°C
 INSUL. RES.: 5000 MEGOHMS

MATERIAL: SEE NOTES	DIMENSIONS ARE IN INCHES TOLERANCES: FRACTIONAL: $\pm 1/64$ ANGULAR: X° $\pm 1'0''$ X°X' $\pm 15''$	UNLESS OTHERWISE SPECIFIED 1) ALL DIMENSIONS ARE IN INCHES (MILLIMETERS) 2) ALL DIMENSIONS ARE AFTER PLATING. 3) BREAK CORNERS & EDGES .005 R. MAX. 4) CHAM. 1ST & LAST THREADS. 5) SURFACE ROUGHNESS 63-MIL-STD-10. 6) DIA.'S ON COMMON CENTERS TO BE CONCENTRIC WITHIN .005 T.I.R. 7) REMOVE ALL BURRS	SV Microwave, Inc. 2400 Centrepark West Drive, Suite 100 West Palm Beach, FL 33409
FINISH: SEE NOTES	DECIMAL: X $\pm .030$.XX $\pm .010$.XXX $\pm .005$	INTERPRET DIMENSIONS AND TOLERANCES PER ASME Y14.5M - 1994	TITLE: SMP MALE HERMETIC SHROUD FULL DETENT
SURFACE AREA: N/A	THIRD ANGLE PROJECTION	DRAWN: HLP 12/03/07	SIZE: B CAGE CODE: 95077 DWG. NO. 1211-6041
PROPRIETARY THE INFORMATION CONTAINED IN THIS DRAWING IS THE SOLE PROPERTY OF SV MICROWAVE, INC. ANY REPRODUCTION IN PART OR AS A WHOLE WITHOUT THE WRITTEN PERMISSION OF SV MICROWAVE, INC IS PROHIBITED.		CHECKED: STW 12/03/07	SCALE: 16:1
		APPROVED: STW 12/03/07	SHEET 1 OF 1