

P	LTR	DESCRIPTION	DATE	DWN	APVD
	D	REVISED PER OL20-0067-97	26MAR97	DKS	MJS
	D1	REVISED PER ECO-17-008808	12FEB2018	RS	DR

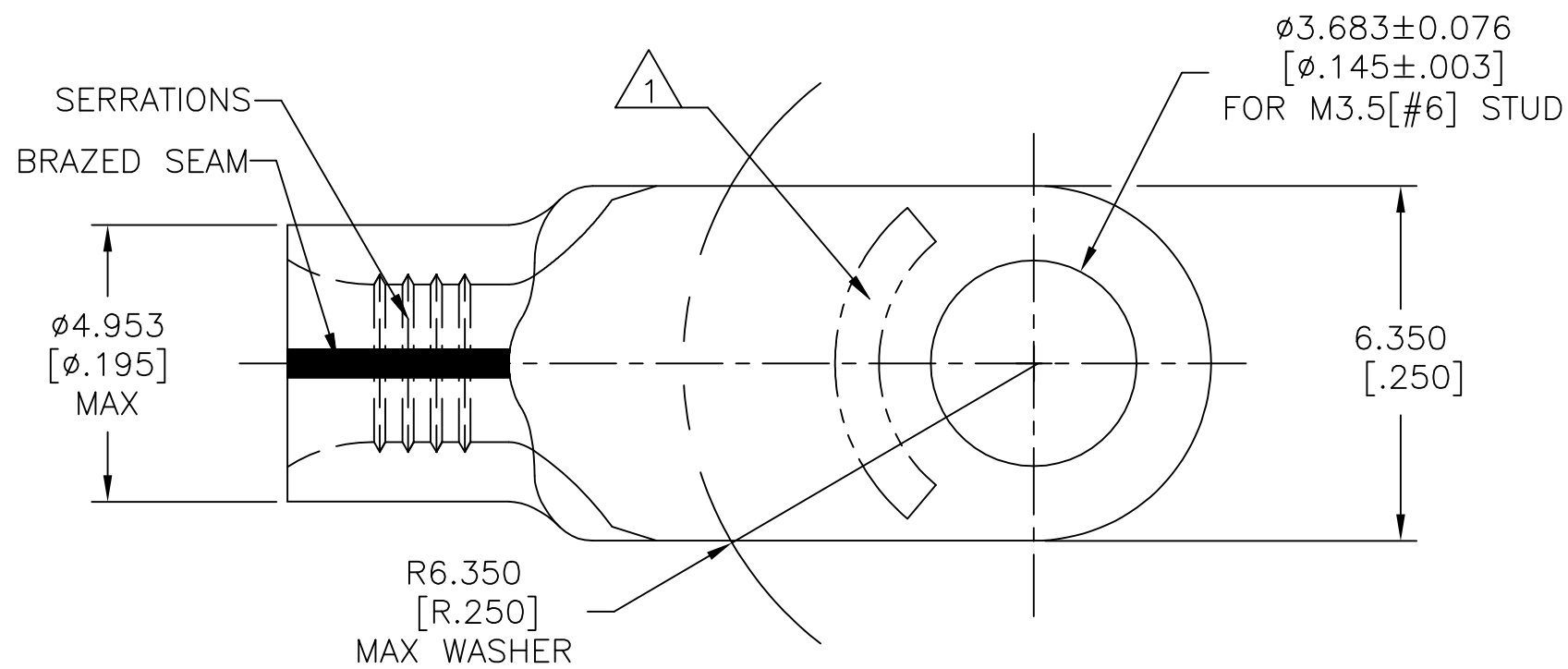

AMP WIRE RANGE	E13288 Listed
14-12 AWG SOLID OR STRANDED	14-12 AWG STRANDED
LR7189 Certified	MILITARY P/N AND CLASS
14-12 AWG SOLID OR STRANDED	NOT APPLICABLE

1 STAMP AMP 14-12* APPROX AS SHOWN

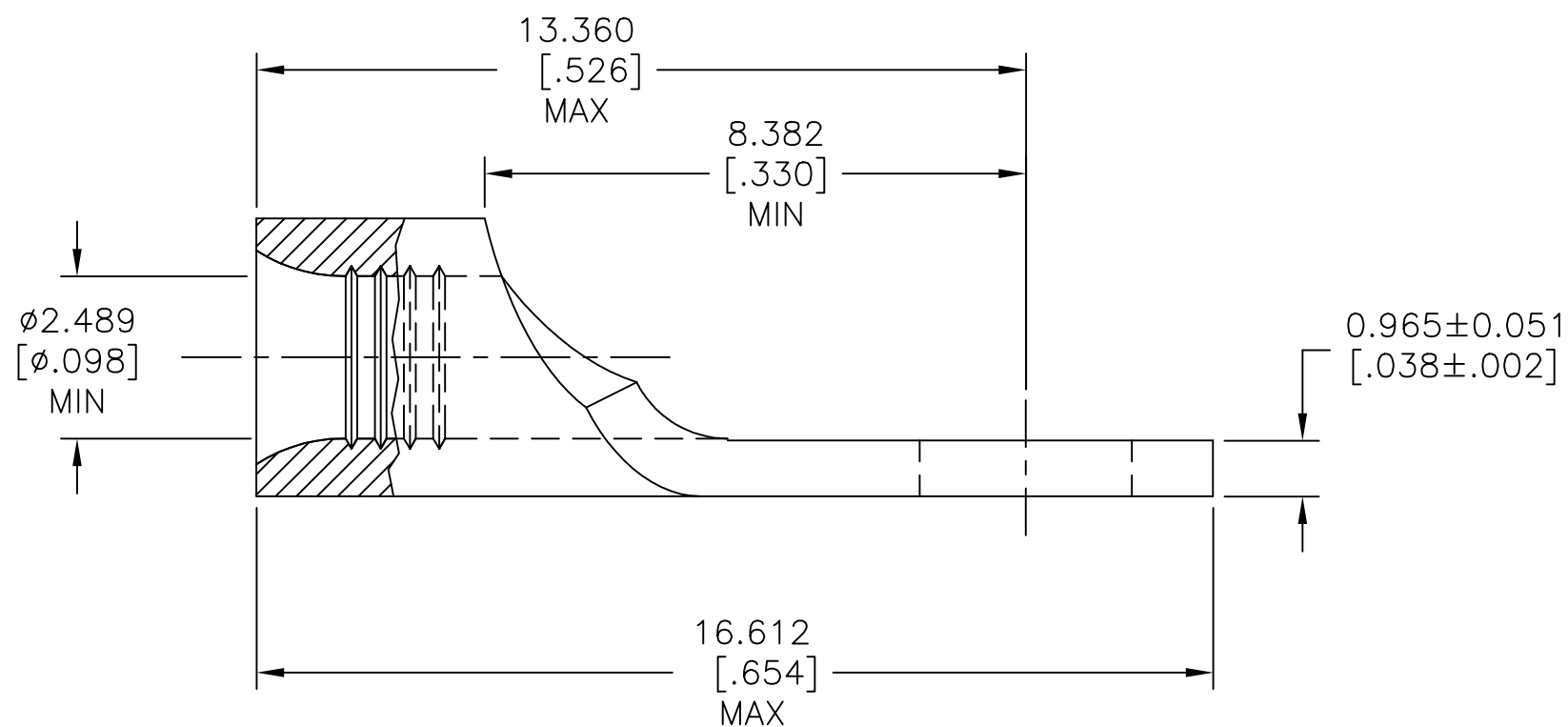

5000	TAPE MOUNTED, REEL	2-35684-1
500	LOOSE PIECE	35684
QTY	PACKAGE TYPE	AMP PART NUMBER

AMP INCORPORATED
CUSTOMER SERVICE SYSTEMS

THIS DRAWING IS A CONTROLLED DOCUMENT.

DWN DK SCHRUM 26MAR97

CHK MJ SPICER 27MAR97

APVD JL MECKLEY 27MAR97

PRODUCT SPEC

UL 486 A-B

APPLICATION SPEC

WEIGHT

CUSTOMER DRAWING

STE TE Connectivity Ltd.

NAME
TERMINAL, RING TONGUE,
SOLISTRAND,™ 14-12 AWG

SIZE	CAGE CODE	DRAWING NO	RESTRICTED TO
A3	00779	C-35684	-

FOR ADDITIONAL PRODUCT INFORMATION OR COPIES OF DRAWINGS AND TECHNICAL DOCUMENTS	PRODUCT INFORMATION CENTER 1-800-522-6752
FOR APPLICATION TOOLING INFORMATION	TOOLING ASSISTANCE CENTER 1-800-722-1111
FOR ORDER ENTRY	1-800-526-5142

MAX RECOMMENDED OPERATING
TEMPERATURE:
170°C [338°F] MAX

VOLTAGE RATING:
NOT APPLICABLE

WIRE CROSS SECTIONAL AREA RANGE,
1.65-4.17mm²[3,260-8,230] CIR MILS
SOLID OR STRANDED

DIMENSIONS: mm [INCHES]	TOLERANCES UNLESS OTHERWISE SPECIFIED:
	0 PLC ± - 1 PLC ± - 2 PLC ± - 3 PLC ± 0.127[.005] 4 PLC ± - ANGLES ± -
MATERIAL PER ASTM B52 ANNEALED	FINISH 0.00254 [0.100] MIN THK PER ASTM B545

SCALE 8:1 SHEET 1 OF 1 REV D1