

LOC	DIST	REVISIONS			
P	LTN	DESCRIPTION	DATE	DWN	APVD
A		REV PER ECR-09-003085	06FEB2009	IL	SY
A1		ADD NEW DASH NUMBER -2	19MAY2009	KT	SY
A2		REVISE DASH NUMBER -2	20MAY2009	KT	SY

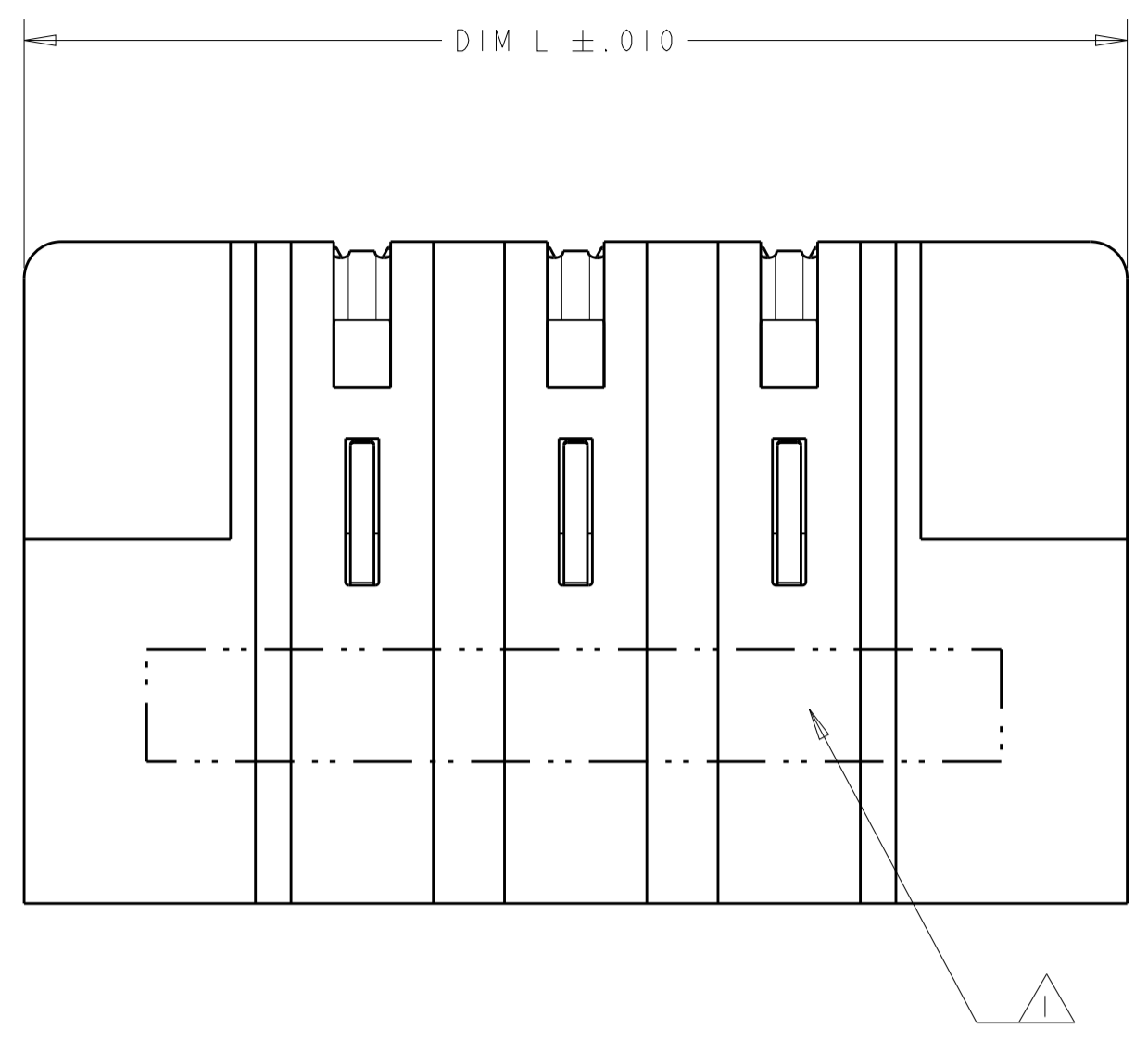

- 1 "AMP", PART NUMBER, AND DATE CODE TO BE MARKED IN AREA SHOWN.
- 2 MATERIAL: HOUSING - GLASS FILLED HIGH TEMP THERMO PLASTIC, UL94 V-0
POWER CONTACT - HIGH CONDUCTIVITY COPPER ALLOY
- 3 CONTACT PLATING: NOBLE METAL PLATING ON CONTACT FUNCTIONAL AREA OF POWER AND SIGNAL CONTACTS.
- 4 MECHANICAL CONNECTOR KEEP OUT ZONE.
- 5 DATUM AND BASIC DIMENSIONS ESTABLISHED BY CUSTOMER.
- 6 PCB- ALL HOLE DIAMETERS ARE FINISHED HOLE SIZES.
- 7 PCB - .0453±.0010 DRILLED HOLES WITH .0003 MIN Sn OVER .001 TO .003 Cu PLATING TO ACHIEVE A .040±.003 DIA HOLE.

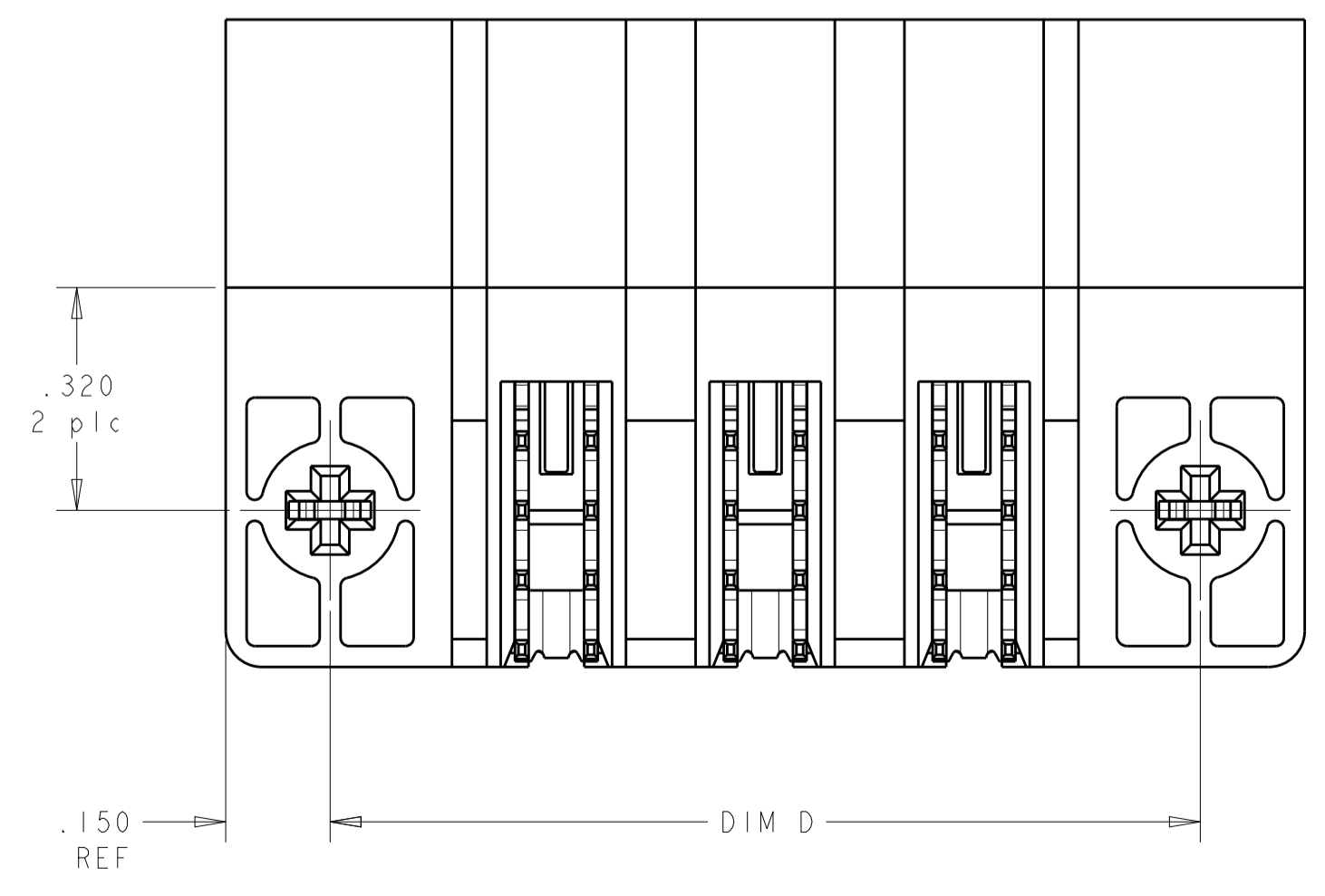
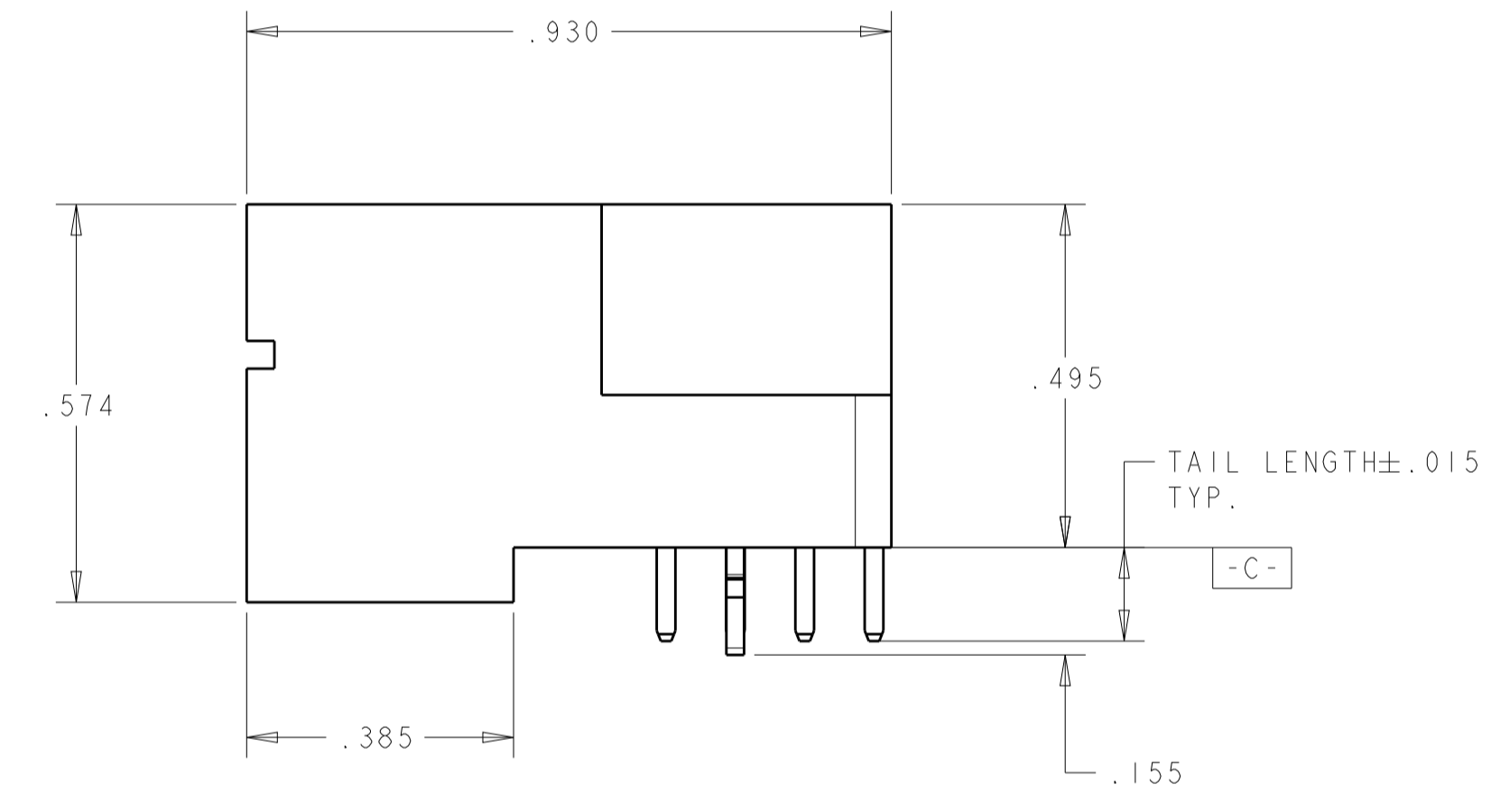
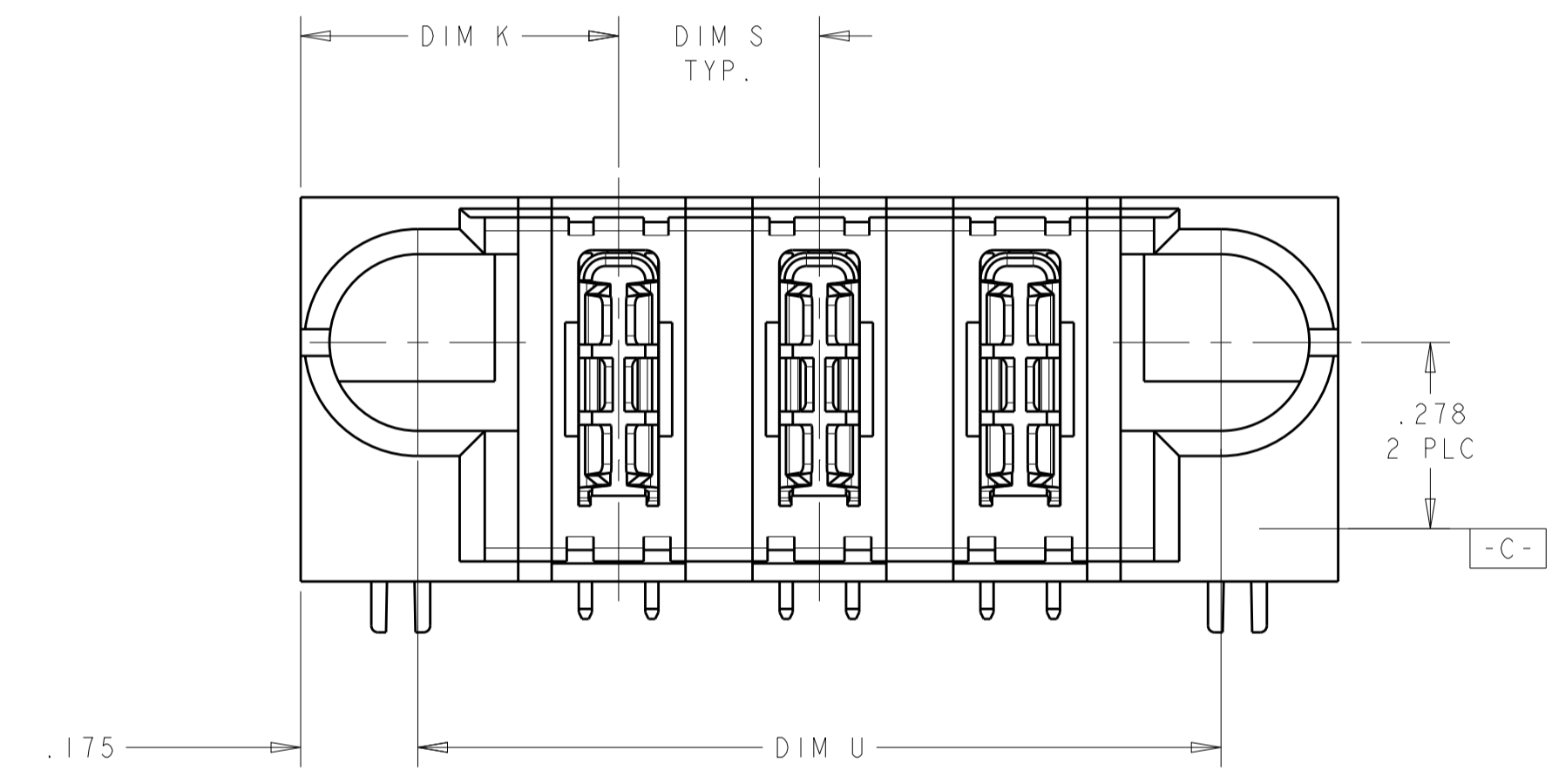

1.400	.375	1.450	.500	1.750	3ACP	1892103-2
1.200	.300	1.250	.475	1.550	3ACP	1892103-1
DIM U	DIM S	DIM D	DIM K	DIM L	DESCRIPTION	PART NUMBER

DIMENSIONS: INCHES 		TOLERANCES UNLESS OTHERWISE SPECIFIED: 0 PLC ±. 1 PLC ±.01 2 PLC ±.01 3 PLC ±.005 4 PLC ±.0020 ANGLES ±.2° FINISH		DWN: L. LEE 06FEB2009 CHK: S. ZHAO 06FEB2009 APVD: S. YAO NAME: S. YAO PRODUCT SPEC: 108-1973 APPLICATION SPEC: 114-13038 WEIGHT: - CUSTOMER DRAWING		Tyco Electronics incorporation Shanghai, P.R.China. 200233 NAME: RIGHT ANGLE HEADER ASSEMBLY W/GUIDES MULTI-BEAM XL SIZE: A1 CAGE CODE: 00779 DRAWING NO: 1892103 SCALE: 3:1 SHEET: 1 OF 2 REV: A2	
---------------------------	--	----------------------------------------------------------------------------------------------------------------------------------------	--	---------------------------------------------------------------------------------------------------------------------------------------------------------------------------	--	----------------------------------------------------------------------------------------------------------------------------------------------------------------------------------------------------------------------------	--

LOC	DIST	REVISIONS			
P	LTN	DESCRIPTION	DATE	DMN	APVD
-	-	SEE SHEET 1	-	-	-

PART NUMBER	ROWS	POWER		
		P1	P2	P3
1892103-1	D C B A	TM	TM	TM
3ACP		HD		HD

PART NUMBER	ROWS	POWER		
		P1	P2	P3
1892103-2	D C B A	TM	TM	TM
3ACP		HD		HD

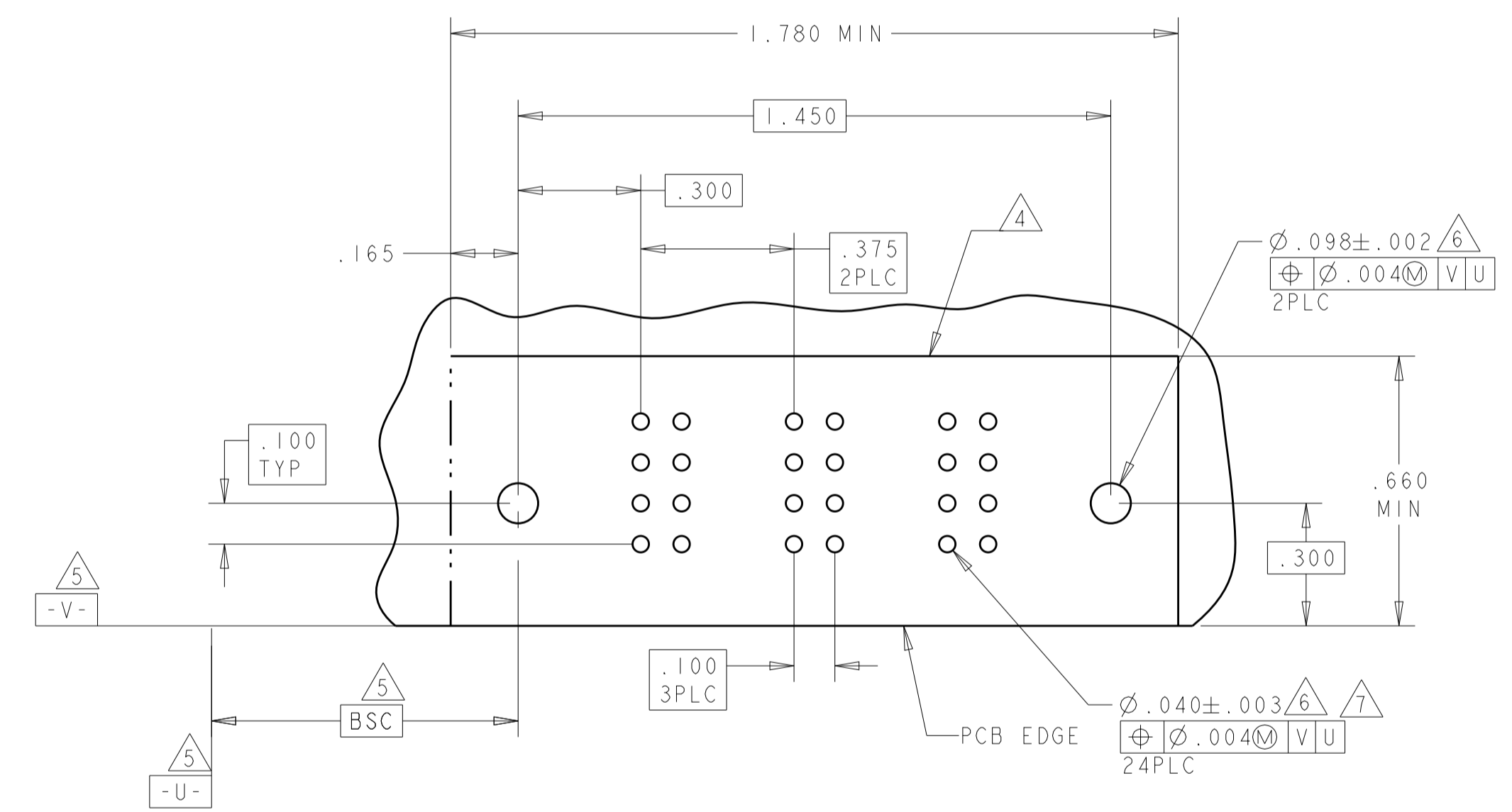
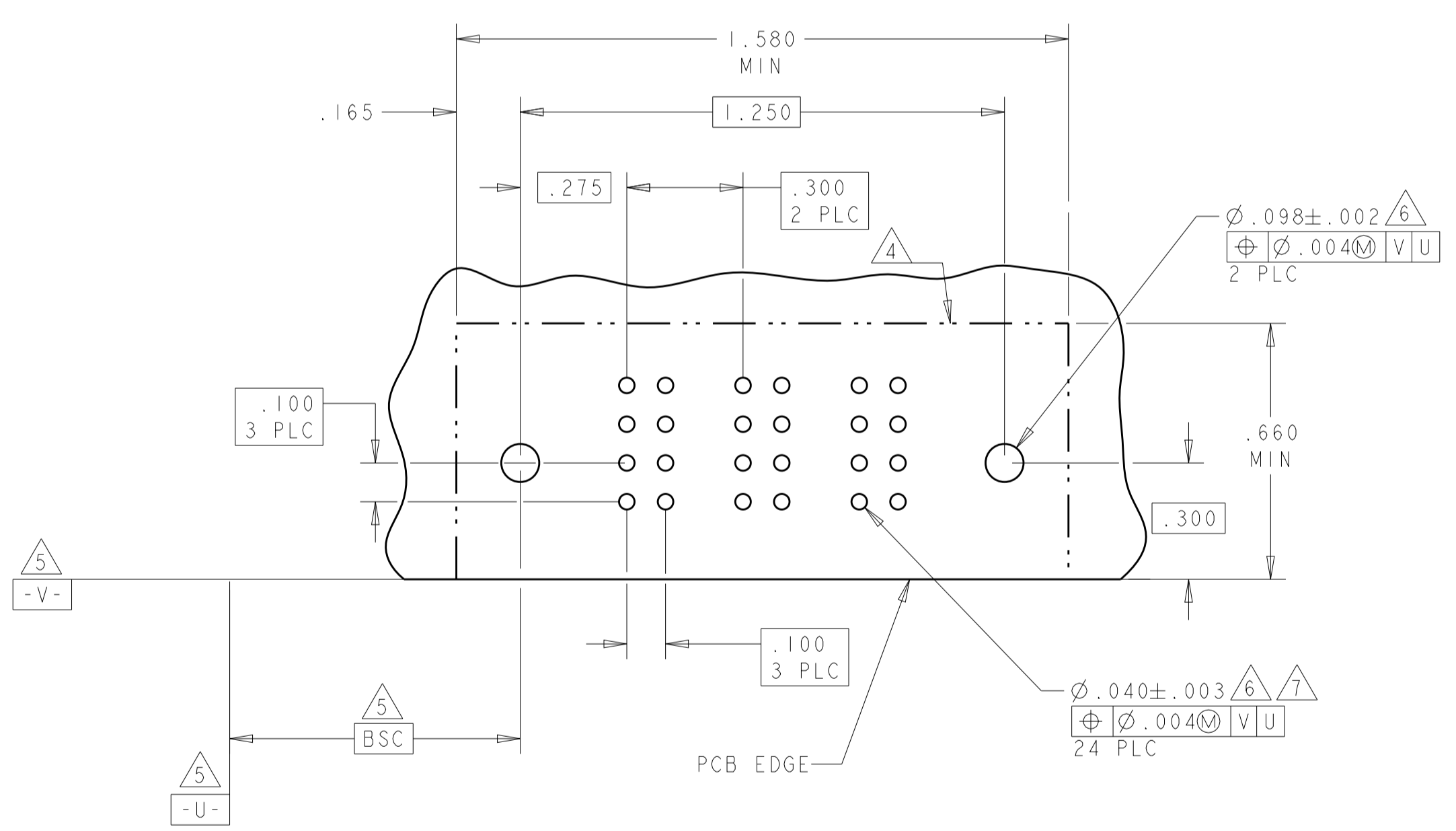

TM	.135
CODE	TAIL LENGTH
POWER CONTACT	

<small>THIS DRAWING IS UNPUBLISHED. RELEASED FOR PUBLICATION. IT IS THE POLICY OF TYCO ELECTRONICS CORPORATION TO CONTROL THE DISTRIBUTION OF THIS DRAWING TO THE EXTENT POSSIBLE. IT IS THE RESPONSIBILITY OF THE USER TO OBTAIN THE LATEST REVISION.</small>		DWN: L. LEE 06FEB2009 CHK: S. ZHAO 06FEB2009 APVD: S. YAO	Tyco Electronics Tyco Electronics incorporation Shanghai, P.R.China. 200233
DIMENSIONS: INCHES	TOLERANCES UNLESS OTHERWISE SPECIFIED: 0 PLC ±. 1 PLC ±.01 2 PLC ±.01 3 PLC ±.005 4 PLC ±.0020 ANGLES ±.2°	NAME: RIGHT ANGLE HEADER ASSEMBLY W/GUIDES MULTI-BEAM XL PRODUCT SPEC: 108-1973 APPLICATION SPEC: SIZE: 114-13038 WEIGHT:	RESTRICTED TO: A1 00779 C=1892103 SCALE: 3:1 SHEET 2 OF 2 REV A2
MATERIAL: -		CUSTOMER DRAWING	