

CODE	DIM "M" MATING LENGTH	CONTACT TYPE
U	[6.86]	SIGNAL
T	[6.86]	SIGNAL
S	[6.86]	SIGNAL
R	[6.86]	SIGNAL
PA	[N/A]	POWER
F	[5.59]	SIGNAL
HA	[N/A]	HOLD-DOWN

spec ref	*	dr	Luo Weller	2012/08/06	projection	MM	size	A4	scale	1:1
tolerance std	TOLERANCES UNLESS OTHERWISE SPECIFIED	eng	Luo Weller	2012/09/14			ecn no	ELX-DG-012833-1		
		chr	-	-				rel level	Released	
surface	linear	appr	Pei-Ming Zheng	2012/09/14	product family	PwrBlade		rev	C	
	angular				cat. no.	&model_name	Product - Customer Drw	sheet 1 of 4		

A

B

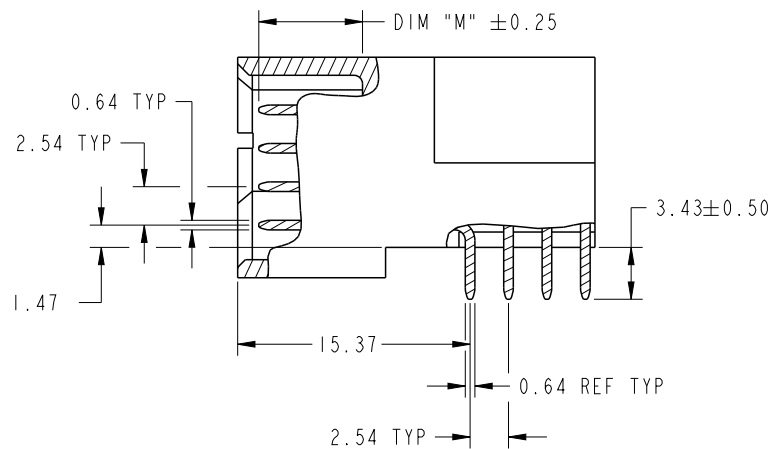

BROKEN-OUT SECTION A-A
SCALE 2:1

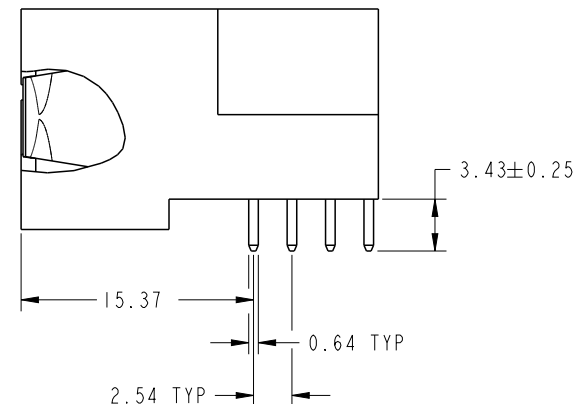

BROKEN-OUT SECTION B-B
SCALE 2:1

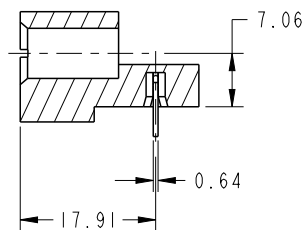

SECTION C-C



Copyright FCI.

C

D

spec ref	*	dr	Luo Weller	2012/08/06	projection 	MM ←→	size	A4	scale	1:1	
tolerance std	TOLERANCES UNLESS OTHERWISE SPECIFIED	eng	Luo Weller	2012/09/14			ecn no	ELX-DG-012833-1			
		chr	-	-							
surface	✓	appr	Pei-Ming Zheng	2012/09/14	product family	PwrBlade		rel level	Released		
linear	0.X	±0.5		title	24S + 8P		dwg no	51939-697		rev	C
	0.XX	±0.25									
0.XXX	±0.1										
angular	0°	±2°	www.fci.com	cat. no.	&model_name	Product - Customer Drw		sheet 2 of 4			

PwrE File - REV C - 2009-06-09



Copyright FCI.

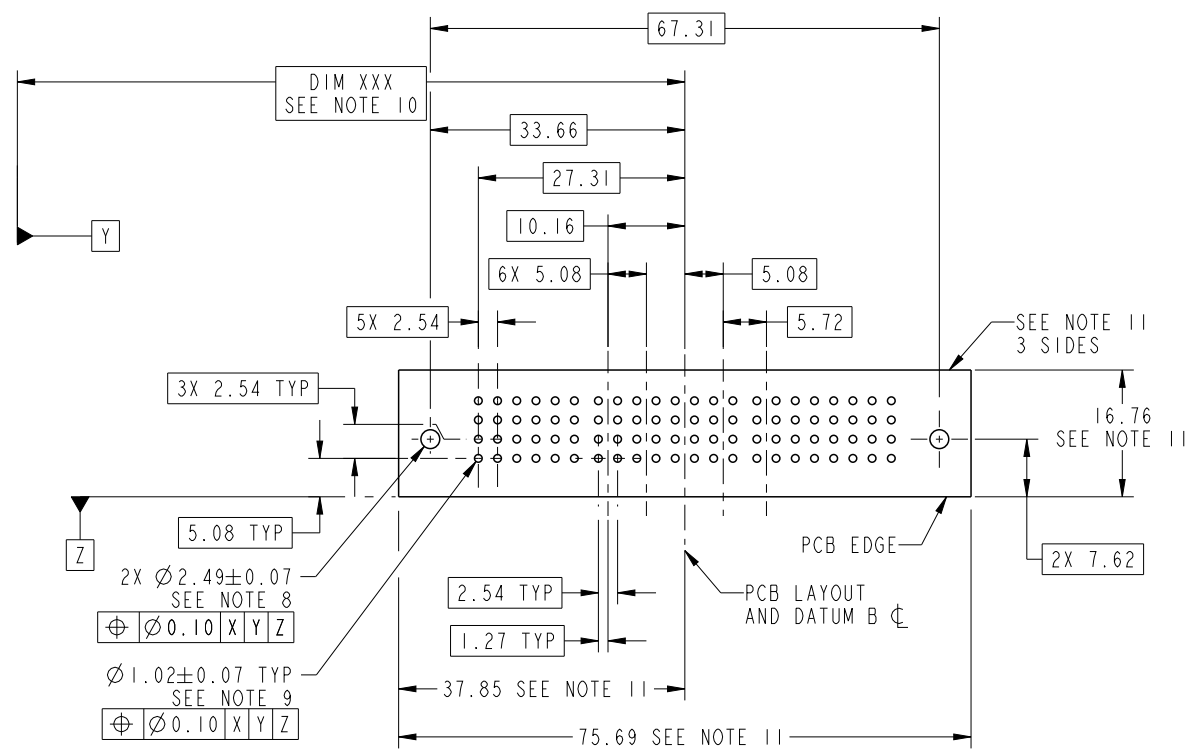

RECOMMENDED PCB LAYOUT

spec ref	*	dr	Luo Weller	2012/08/06	projection	MM ←→	size	A4	scale	1:1	
tolerance std	TOLERANCES UNLESS OTHERWISE SPECIFIED	eng	Luo Weller	2012/09/14			ecn no	ELX-DG-012833-1			
		chr	-	-				rel level	Released		
surface	✓	appr	Pei-Ming Zheng	2012/09/14	product family	PwrBlade					
	linear				title	24S + 8P		dwg no	51939-697		
						RIGHT ANGLE SOLDER HEADER			rev		
	angular				cat. no.	&model_name	Product - Customer Drw		sheet 3 of 4		

PrdE File - REV C - 2009-06-09

NOTES:

1. DIMENSIONS AND TOLERANCES ARE IN ACCORDANCE WITH ASME Y14.5M, 1994 UNLESS OTHERWISE SPECIFIED.

CONNECTOR NOTES:

- 2. HOUSING MATERIAL: UL 94 V-0 GLASS FILLED HIGH-TEMP THERMOPLASTIC
POWER CONTACT MATERIAL: COPPER ALLOY
SIGNAL PIN MATERIAL: COPPER ALLOY
- 3. SEE ITEM 1 & 2 IN PRINT 10064183 FOR PLATING SPEC OF 51939-697 AND 51939-697LF RESPECTIVELY.
- 4. MANUFACTURER'S NAME, DATE CODE AND OPTIONAL P/N TO APPEAR ON THIS SURFACE. THE MARK CAN BE OMITTED IF THERE IS NOT ENOUGH SPACE ON THIS SURFACE.
- 5. PRODUCT SPECIFICATION GS-12-149.
APPLICATION SPECIFICATION BUS-20-067.
- 6. PACKAGED IN TRAYS.

PCB NOTES:

- 7. ALL HOLE DIAMETERS ARE FINISHED HOLE SIZE.
- 8. MOUNTING HOLES, WHERE APPLICABLE, ARE UNPLATED.
- 9. $\varnothing 1.151 \pm 0.025$ DRILLED HOLES PLATED WITH
0.008 MIN SnPb OR Sn OVER 0.03
TO 0.08 Cu PLATING TO ACHIEVE
 $\varnothing 1.02 \pm 0.07$ HOLE.
- 10. "DIM XXX" TO BE DETERMINED BY THE CUSTOMER.
- 11. CONNECTOR KEEP-OUT ZONE.

spec ref *		dr Luo Weller		2012/08/06	projection 	MM 	size A4	scale 1:1	
tolerance std	TOLERANCES UNLESS OTHERWISE SPECIFIED			eng Luo Weller			2012/09/14	ecn no ELX-DG-012833-1	
				chr -			-	rel level Released	
		appr Pei-Ming Zheng		2012/09/14	product family PwrBlade				
surface	linear	0.X	± 0.5		title 24S + 8P	dwg no 51939-697	rev C		
		0.XX	± 0.25						
		0.XXX	± 0.1						
	angular	0°	$\pm 2^\circ$	www.fci.com	cat. no.	&model_name	Product - Customer Drw	sheet 4 of 4	



Copyright FCI.