

PLT5 488

Metal Can® TO56

Blue-Cyan Laser Diode in TO56 Package



Applications

- Health Monitoring (Heart Rate Monitoring, Pulse Oximetry)
- Measurement Levelling

Features:

- ESD: 2 kV acc. to ANSI/ESDA/JEDEC JS-001 (HBM)
- Optical output power (continuous wave): 60 mW ($T_{\text{case}}=25^{\circ}\text{C}$)
- Typical emission wavelength: 488 nm \pm 2 nm
- Typical emission wavelength: 488 nm \pm 5 nm
- Brilliant beam technology for side lobes free beam
- High modulation bandwidth
- TO56 package with monitor and ESD protection diode
- Efficient radiation source for cw and pulsed operation
- Single tranverse mode semiconductor laser

Ordering Information

Type	Peak output power typ. P_{opt}	Ordering Code
PLT5 488	60 mW	Q65111A5770
PLT5 488-C1C6	60 mW	Q65112A6302

PLT5 488 with wavelength selection: \pm 2 nm

PLT5 488-C1C6 with wavelength selection: \pm 5 nm

Maximum Ratings

$T_{\text{case}} = 25\text{ °C}$

Parameter	Symbol		Values
Operating temperature	T_{op}	min.	-20 °C
		max.	60 °C
Storage temperature	T_{stg}	min.	-40 °C
		max.	85 °C
Junction temperature	T_{j}	max.	150 °C
Forward current ¹⁾	I_{F}	max.	150 mA
Reverse voltage ²⁾	V_{R}	max.	5 V
Reverse voltage ²⁾	V_{R}	max.	5 V
Soldering temperature	T_{S}	max.	260 °C

$t_{\text{max}} = 10\text{ s}$

Operation outside these conditions may damage the device. Operation at maximum ratings may influence lifetime.

Characteristics

$P_{\text{opt}} = 60 \text{ mW}$; $T_{\text{case}} = 25 \text{ °C}$

Parameter	Symbol		Values
Reverse current ²⁾	I_{R}	max.	10 μA
Peak wavelength ³⁾ PLT5 488	λ_{peak}	min. typ. max.	486 nm 488 nm 490 nm
Peak Wavelength ³⁾ PLT5 488-C1C6	λ_{peak}	min. typ. max.	483 nm 488 nm 493 nm
Operating current ¹⁾	I_{op}	typ. max.	85 mA 100 mA
Spectral bandwidth at 50% $I_{\text{e,rel,max}}$	$\Delta\lambda$	typ.	1 nm
Beam divergence (FWHM) parallel to pn-junction	Θ_{\parallel}	min. typ. max.	4 ° 6 ° 8 °
Beam divergence (FWHM) perpendicular to pn-junction	Θ_{\perp}	min. typ. max.	16 ° 23 ° 25 °
Monitor current ⁴⁾⁵⁾	I_{m}	typ.	40 μA
Threshold current	I_{th}	typ. max.	25 mA 40 mA
Forward voltage ⁶⁾	V_{F}	typ. max.	6.0 V 7.5 V
TE polarization	P_{TE}	typ.	100:1
Modulation frequency	f	min.	100 MHz
Thermal resistance junction case real	R_{thJC}	typ.	34 K / W

Relative Spectral Emission 7), 8)

$$P_{\text{opt}} = f(\lambda)$$

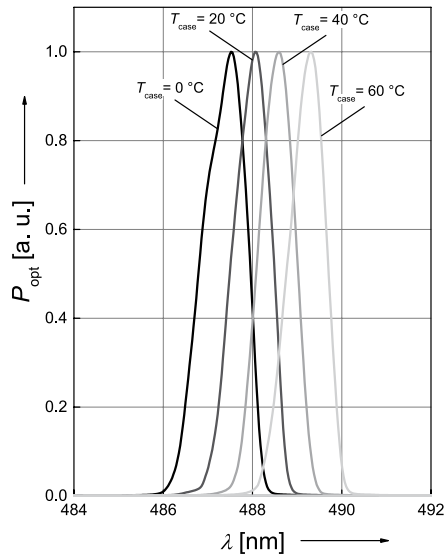

Beam Divergence 7), 8)

$$P_{\text{opt}} = f(\Theta)$$

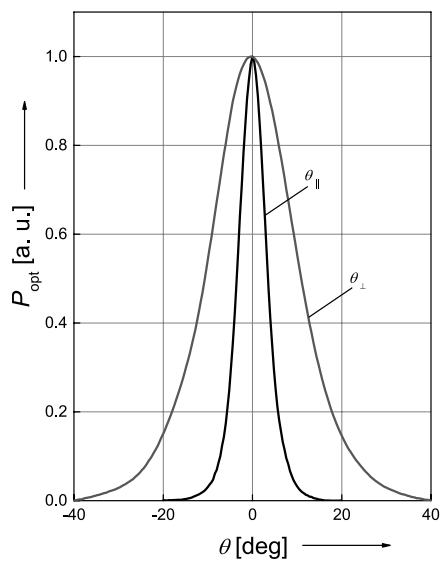

Optical Output Power ^{7), 8)}

$$P_{\text{opt}} = f(I_F)$$

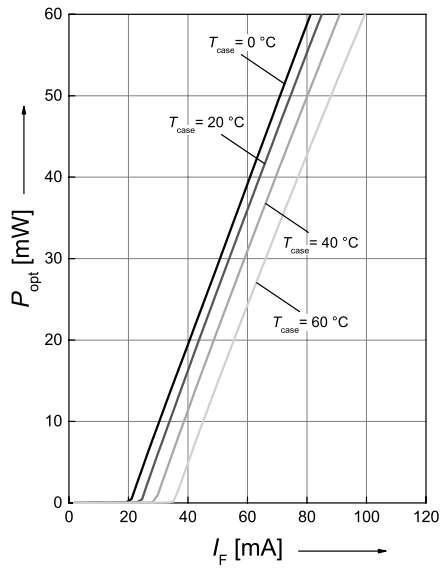

Threshold Current ⁷⁾

$$I_{\text{th}} = f(T_A)$$

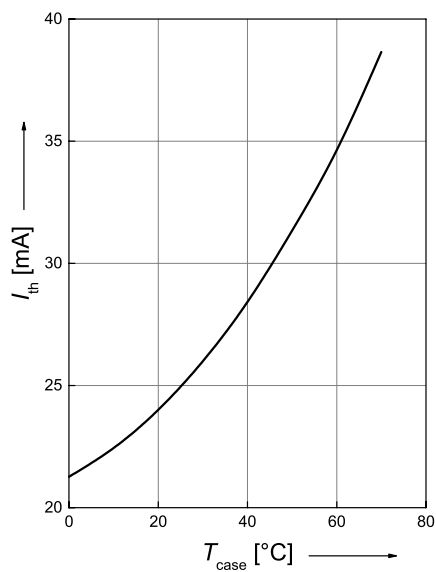

Opt. Power / Forward Voltage 7), 8)

$$V_F = f(I_F)$$

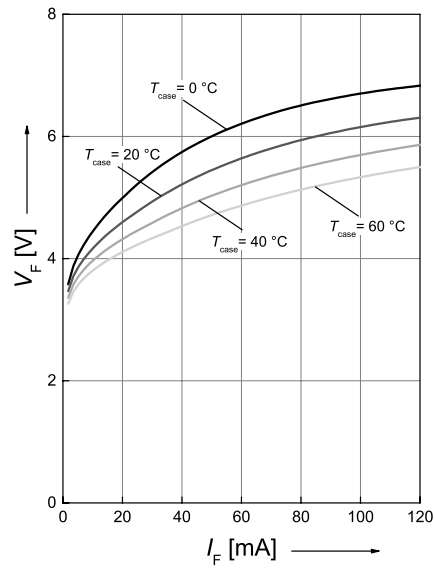

Dimensional Drawing ⁹⁾

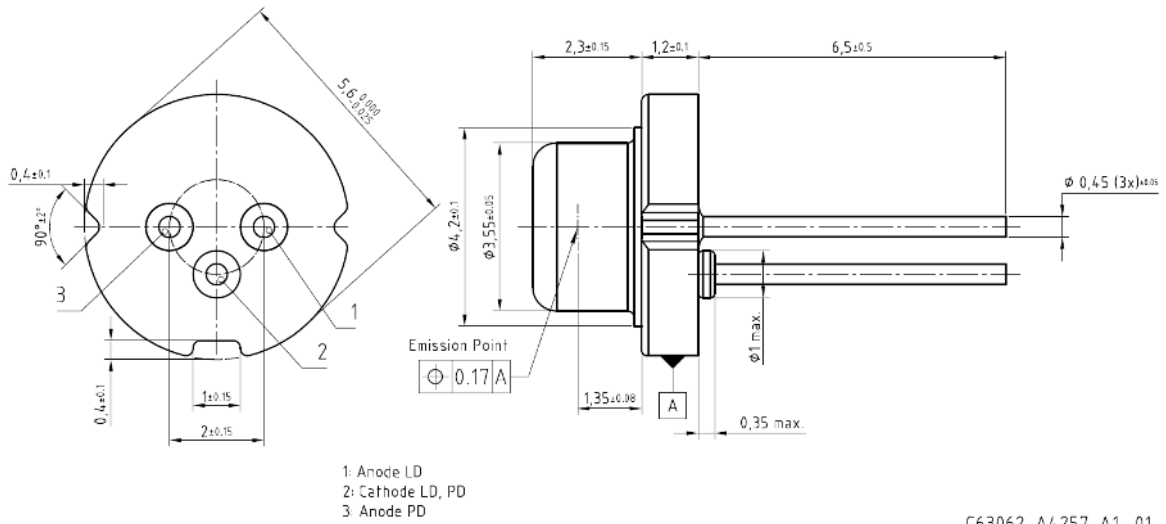

C63062-A4257-A1-01

Further Information

Approximate Weight: 310.0 mg

Electrical Internal Circuit

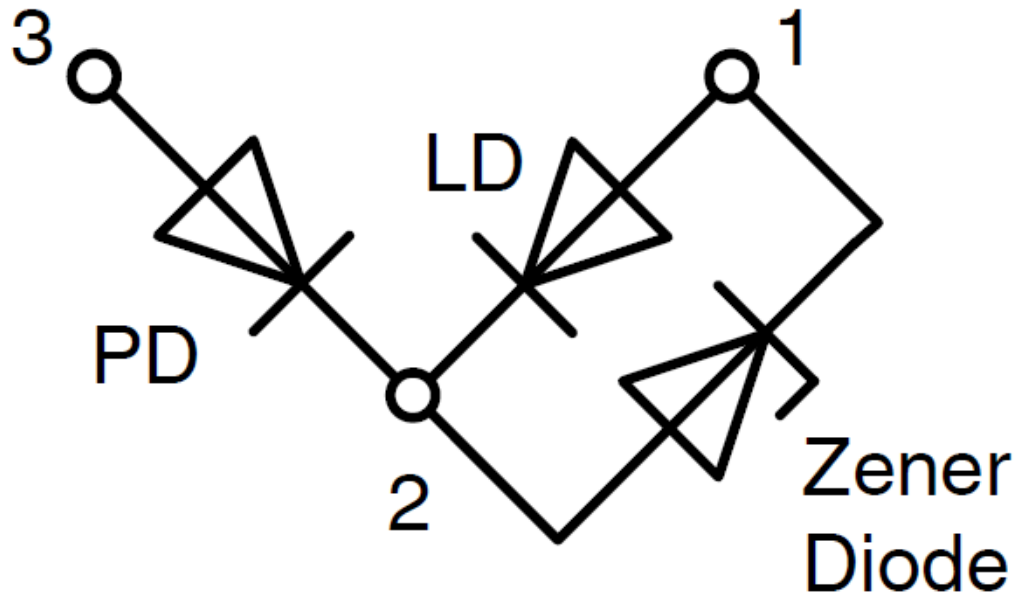

Pin	Description
PIN 1	LD Anode
PIN 2	LD Cathode, PD Cathode (case)
PIN 3	PD Anode

Taping ⁹⁾

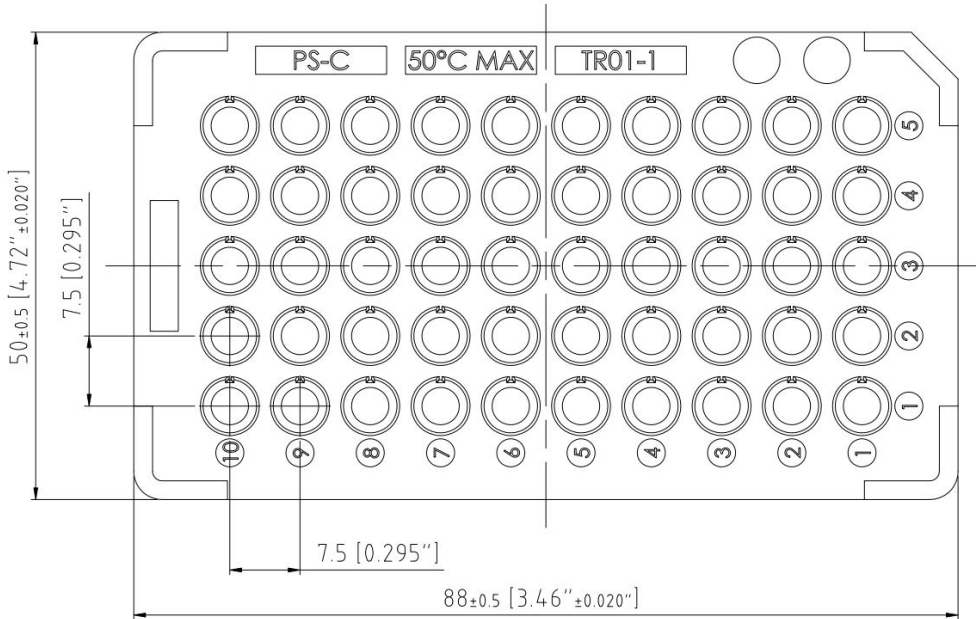

Barcode-Product-Label (BPL)

OSRAM Opto Semiconductors LX XXXX BIN1: XX-XX-X-XXX-X

RoHS Compliant

(6P) BATCH NO: 1234567890 ML Temp ST
X XXX °C X

(1T) LOT NO: 1234567890 (9D) D/C: 1234

Pack: RXX
 DEMY XXX
 X_X123_1234.1234 X

(X) PROD NO: 123456789 (Q) QTY: 9999 (G) GROUP: XX-XX-X-X

OHA04563

Schematic Transportation Box ⁹⁾

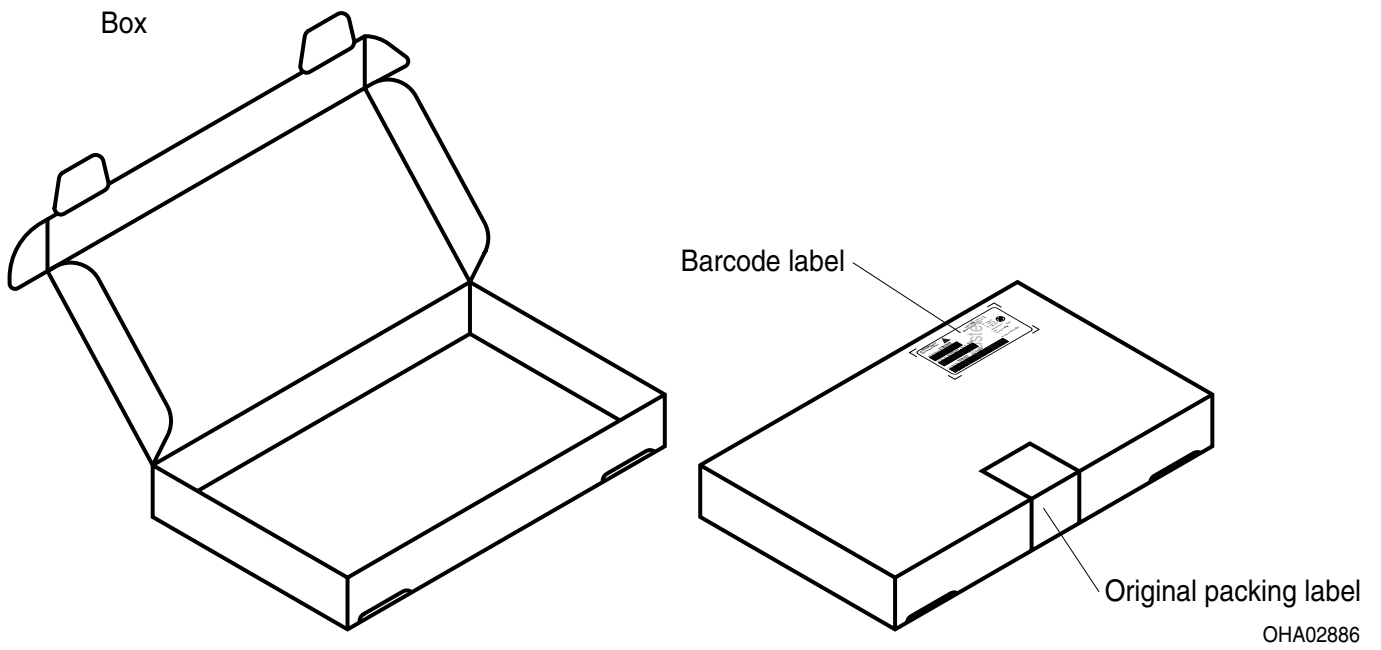

Dimensions of Transportation Box

Width

Length

Height

Notes

Depending on the mode of operation, these devices emit highly concentrated visible and non visible light which can be hazardous to the human eye. Products which incorporate these devices have to follow the safety precautions given in IEC 60825-1.

Subcomponents of this device contain, in addition to other substances, metal filled materials including silver. Metal filled materials can be affected by environments that contain traces of aggressive substances. Therefore, we recommend that customers minimize device exposure to aggressive substances during storage, production, and use. Devices that showed visible discoloration when tested using the described tests above did show no performance deviations within failure limits during the stated test duration. Respective failure limits are described in the IEC60810.

Important notes of operation for laser diode

a) Electrical operation

OSRAMs laser diodes are designed for maximum performance and reliability. Operating the laser diode above the maximum rating even for very short periods of time can damage the laser diode or reduce its lifetime. The laser diode must be operated with a suitable power supply with minimized electrical noise. The laser diode is very sensitive to electrostatic discharge (ESD). Proper precautions must be taken.

b) Mounting instructions

In order to maintain the lifetime of the laser diode proper heat management is essential. Due to the design of the laser diode heat is dissipated only through the base plate of the diode's body. A proper heat conducting interconnection between the diodes base plate and the heat sink must be maintained.

For further application related informations please visit www.osram-os.com/appnotes

Depending on the mode of operation, these devices emit highly concentrated non visible infrared light which can be hazardous to the human eye. Products which incorporate these devices have to follow the safety precautions given in IEC 60825-1 and IEC 62471.

Disclaimer

Attention please!

The information describes the type of component and shall not be considered as assured characteristics. Terms of delivery and rights to change design reserved. Due to technical requirements components may contain dangerous substances.

For information on the types in question please contact our Sales Organization.

If printed or downloaded, please find the latest version on the OSRAM OS website.

Packing

Please use the recycling operators known to you. We can also help you – get in touch with your nearest sales office.

By agreement we will take packing material back, if it is sorted. You must bear the costs of transport. For packing material that is returned to us unsorted or which we are not obliged to accept, we shall have to invoice you for any costs incurred.

Product safety devices/applications or medical devices/applications

OSRAM OS components are not developed, constructed or tested for the application as safety relevant component or for the application in medical devices.

In case Buyer – or Customer supplied by Buyer– considers using OSRAM OS components in product safety devices/applications or medical devices/applications, Buyer and/or Customer has to inform the local sales partner of OSRAM OS immediately and OSRAM OS and Buyer and /or Customer will analyze and coordinate the customer-specific request between OSRAM OS and Buyer and/or Customer.

Glossary

- 1) **Operating/Forward current:** IF is measured with an internal reproducibility of $\pm 7\%$ (acc. to GUM with a coverage factor of $k = 3$).
- 2) **Reverse Operation:** Reverse Operation of 10 hours is permissible in total. Continuous reverse operation is not allowed.
- 3) **Wavelength:** λ_{peak} is measured with an internal reproducibility of $\pm 0.3\text{ nm}$ (acc. to GUM with a coverage factor of $k = 3$).
- 4) **Monitor current:** Monitor current refers to a reverse voltage of $\text{VRPD} = 5\text{ V}$. Monitor current is for short time power reference purpose only. Not guaranteed for accuracy.
- 5) **Monitor current:** For reference only.
- 6) **Operating/Forward voltage:** VF is measured with an internal reproducibility of $\pm 0.05\text{ V}$ (acc. to GUM with a coverage factor of $k = 3$).
- 7) **Typical Values:** Due to the special conditions of the manufacturing processes of semiconductor devices, the typical data or calculated correlations of technical parameters can only reflect statistical figures. These do not necessarily correspond to the actual parameters of each single product, which could differ from the typical data and calculated correlations or the typical characteristic line. If requested, e.g. because of technical improvements, these typ. data will be changed without any further notice.
- 8) **Testing temperature:** $T_A = 25^\circ\text{C}$
- 9) **Tolerance of Measure:** Unless otherwise noted in drawing, tolerances are specified with ± 0.1 and dimensions are specified in mm.

Revision History

Version	Date	Change
1.0	2019-01-24	Additional Information
