

STRIP MATERIAL NUMBER	LOOSE PIECE MATERIAL NUMBER	AWG SIZE	DIM. "A"	DIM. "B"	DIM. "C"	DIM. "D"	WIRE INSULATION DIAMETER
194340001	194340003	10-12	.250/6.35	.236/6.00	.197/5.00	.226/5.74	.153-.191* (3.90-4.85MM)
194340002	194340004	8	N/A	N/A	.240/6.10	.276/7.00	.248-.264* (6.30-6.70MM)

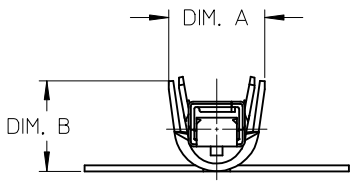

INSULATION CRIMP

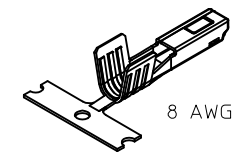
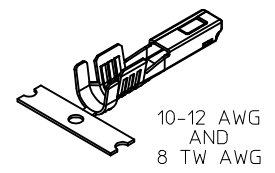
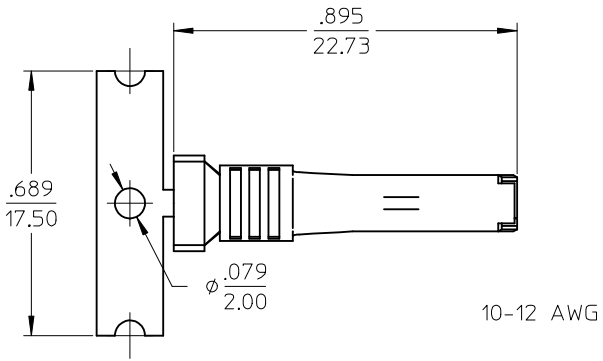
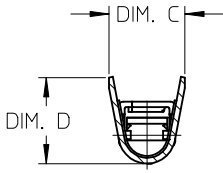

CONDUCTOR CRIMP SECTION A-A

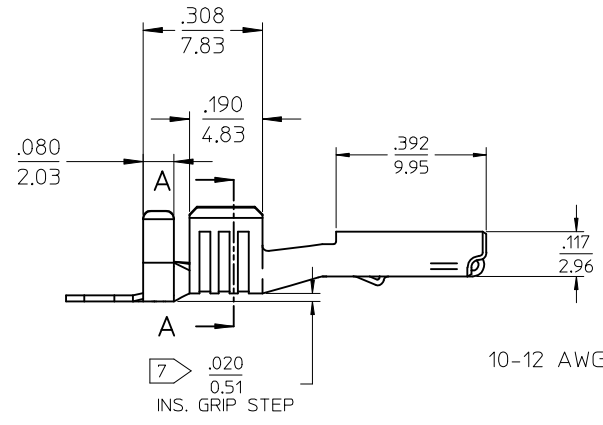

10-12 AWG

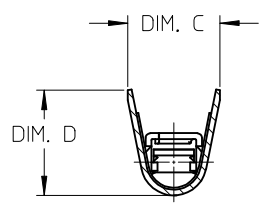
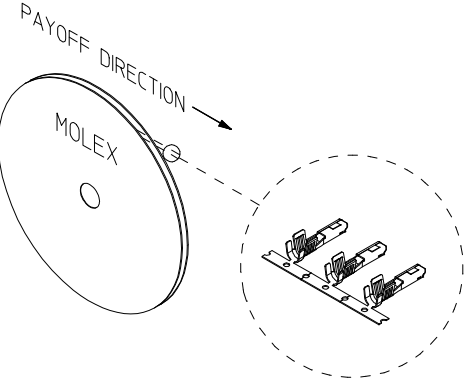

CONDUCTOR CRIMP ONLY SECTION B-B

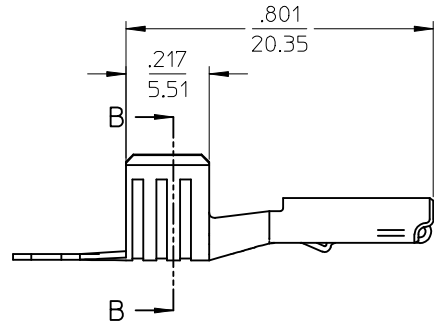

8 AWG SAME AS 10-12 AWG EXCEPT AS NOTED

- NOTES:
1. MATERIAL: COPPER ALLOY.
 2. FINISH: PREPLATED AND REFLOWED OVERALL. 100μ TIN OVER 50μ NICKEL, MINIMUM.
 3. TERMINALS FOR USE WITH 19432**** RECEPTACLE HOUSING ASSEMBLY.
 4. PRODUCT SPECIFICATION: PS-19431-001.
 5. PACKAGING SPECIFICATION: PK-19434-001 FOR LOOSE TERMINALS. STRIP PARTS ARE REELED 2500 TERMINALS PER REEL.
 6. APPLICATION TOOLING AND CRIMP SPECIFICATIONS: CONSULT FACTORY
 7. FOR 10-12 AWG TERMINAL: INSULATION GRIP STEP DIMENSION NOT TO BE ALTERED BY CRIMP PROCESS.
 8. ALL DIMENSIONS ARE REFERENCE.

ADD NOTES 7 & 8 EC NO: IFG2013-1364 DRWN: WLEUNG 2013/06/11 CHKD: BRUPERT 2013/09/06 APPR: JEMURPHY 2013/12/26	QUALITY SYMBOLS	GENERAL TOLERANCES (UNLESS SPECIFIED)	SCALE 4:1	DESIGN UNITS INCH	THIRD ANGLE PROJECTION	REVISE ON CAD ONLY	
	▽ - 0		mm	INCH	DIMENSION STYLE IN/MM		
	▽ C - 0	4 PLACES ± --- ± ---	DRAWN BY BRUPERT	DATE 01/25/05	TITLE FEMALE RECEPTACLE MX150L TERMINAL, 10-12.8 AWG AWG, .098/2.50X.031/0.79 MOLEX MOLEX INCORPORATED		
		3 PLACES ± --- ± .010	CHECKED BY JPAWLICK	DATE 01/25/05			
	2 PLACES ± 0.25 ± .02	APPROVED BY RDEROSS	DATE 01/25/05	MATERIAL NO. SEE CHART	DOCUMENT NO. SD-19434-001	SHEET NO. 1 OF 1	
	1 PLACE ± 0.5 ± ---	DRAFT WHERE APPLICABLE MUST REMAIN WITHIN DIMENSIONS THIS DRAWING CONTAINS INFORMATION THAT IS PROPRIETARY TO MOLEX INCORPORATED AND SHOULD NOT BE USED WITHOUT WRITTEN PERMISSION					