

## SPECIFICATION CONTROL DRAWING

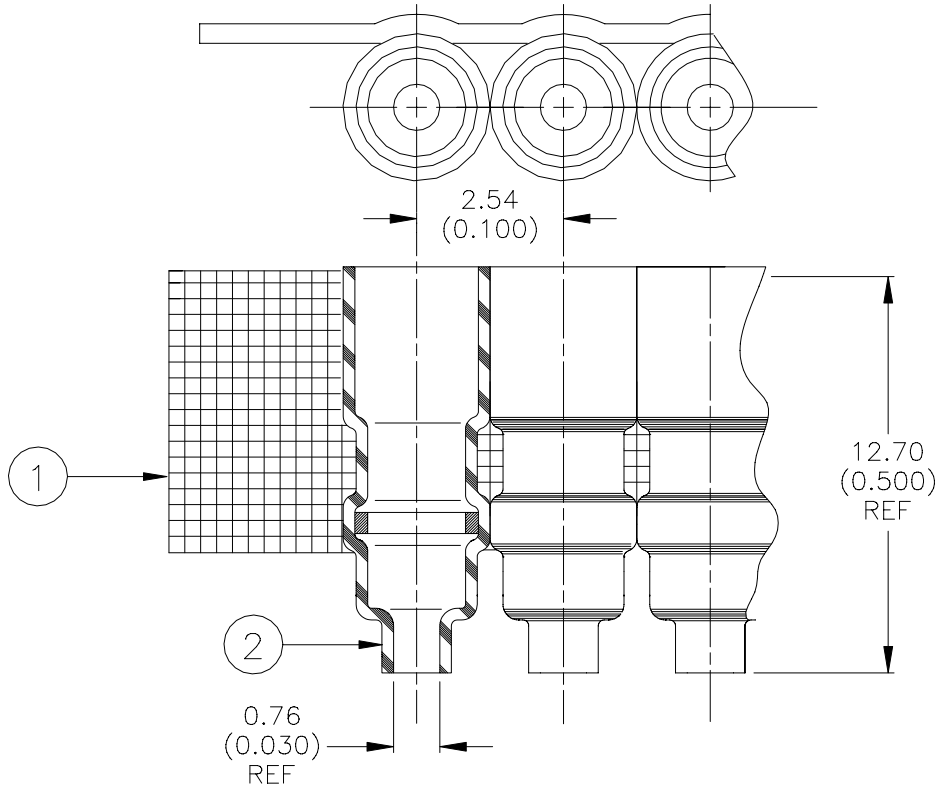

### MATERIALS

1. SOLDERSLLEEVE: D-141-31. Quantity Per Assembly: 1000
2. CARRIER STRIP: Adhesive Coated High Temperature Tape

### APPLICATION

1. This assembly is designed for terminating 26 AWG to 22 AWG PVC wire to connectors having 0.64 (0.025) diameter pins on 2.54 (0.100) center spacing.
2. Sleeves are to be installed using AD-1323 wire holding fixture, AD-1325 connector holding fixture and IR-1012 infrared heater.
3. For certain applications, the CV-4505 shop air heater and AD1327 wire holding fixture may be used.
4. See page 2 for assembly procedure.

<b>tyco</b> <i>Electronics</i>	<b>Raychem</b>	Tyco Electronics Corporation 300 Constitutional Drive Menlo Park, CA 94025 USA	TITLE: <b>SOLDERPAK ASSEMBLY, BURNDY UPC CONNECTOR</b> ø0.64x5.08 (ø0.025x0.200) Terminals with 2.54 (0.100) center spacing				
UNLESS OTHERWISE SPECIFIED DIMENSIONS ARE IN MILLIMETERS. INCHES DIMENSIONS ARE BETWEEN BRACKETS.			DOCUMENT NO.: <b>D-711-04</b>				
TOLERANCES: 0.00 N/A 0.0 N/A 0 N/A	ANGLES: N/A  ROUGHNESS IN MICRON	Raychem reserves the right to amend this drawing at any time. Users should evaluate the suitability of the product for their application.	DATE:  18-July-00	DOC ISSUE:  1			
DRAWN BY: M. FORONDA	CAGE CODE: 06090	REPLACES: N/A	DCR NUMBER: D000404	PROD. REV.: B	SCALE: None	SIZE: A	SHEET: 1 of 2

If this document is printed it becomes uncontrolled. Check for the latest revision.

# SPECIFICATION CONTROL DRAWING

## THERMOFIT ASSEMBLY PROCEDURE

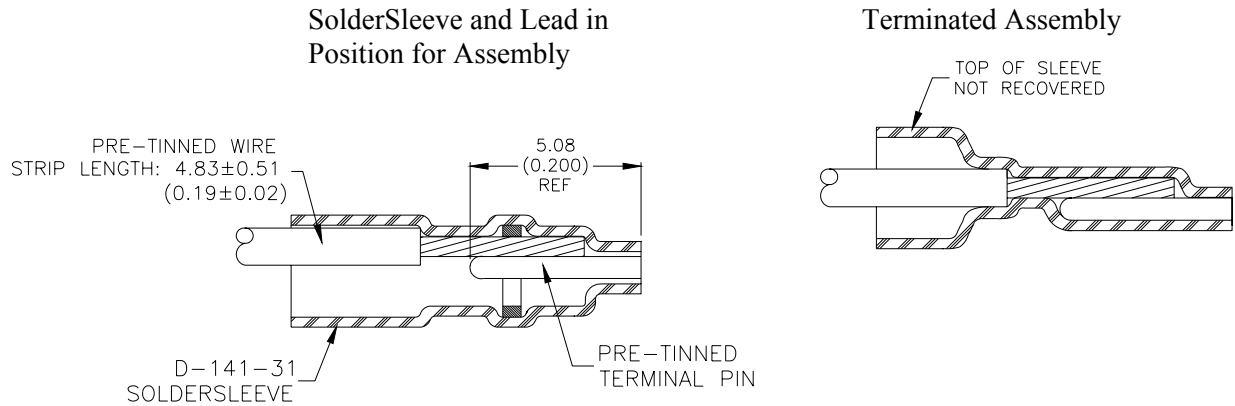

### INSTALLATION PROCEDURE:

1. Terminals must be tinned prior to placement of sleeves.
2. Cut the correct number of sleeves from the reel.
3. Position sleeves onto connector terminals as shown above and remove tape.
4. Strip wire 4.83 (0.19) and pre-tin.
5. Insert wires into sleeves. Wires should be straight and parallel to terminal.
6. Heating Technique:
  - a. Infrared Heater IR-1012: Position connector into holding fixture. Place leads to be connected into correct sleeve. Position heater and energize, after setting timer for correct cycle.
  - b. Convection Heater CV-4505: Position connector into AD-1327 holding fixture. Place leads to be connected into correct sleeve. Regulate airflow through nozzle to achieve an air temperature of 600° - 650°F at a point 7.62 (0.30) from the nozzle, (about 2.5 to 3 psig).  
Apply heat until solder flow is noted.
7. Heat should be applied until solder melts and flows. The insulation sleeve will partially recover down onto the wire insulation near the solder joint. The tops of the sleeves should not recover onto the wire insulation as shown above.

<b>tyco</b> <i>Electronics</i>	<b>Raychem</b>	Tyco Electronics Corporation 300 Constitutional Drive Menlo Park, CA 94025 USA	TITLE: <b>SOLDERPAK ASSEMBLY, BURNDY UPC CONNECTOR</b> ø0.64x5.08 (ø0.025x0.200) Terminals with 2.54 (0.100) center spacing				
UNLESS OTHERWISE SPECIFIED DIMENSIONS ARE IN MILLIMETERS. INCHES DIMENSIONS ARE BETWEEN BRACKETS.			DOCUMENT NO.: <b>D-711-04</b>				
TOLERANCES: 0.00 N/A 0.0 N/A 0 N/A	ANGLES: N/A  ROUGHNESS IN MICRON	Raychem reserves the right to amend this drawing at any time. Users should evaluate the suitability of the product for their application.	DATE:  18-July-00	DOC ISSUE:  1			
DRAWN BY: M. FORONDA	CAGE CODE: 06090	REPLACES: N/A	DCR NUMBER: D000404	PROD. REV.: B	SCALE: None	SIZE: A	SHEET: 2 of 2

If this document is printed it becomes uncontrolled. Check for the latest revision.