

# UBA2024

## Half-bridge power IC for CFL lamps

Rev. 6.2 — 1 November 2010

Product data sheet

### 1. General description

---

The UBA2024 is a family of high-voltage monolithic Integrated Compact Fluorescent Lamp (CFL) drivers for a large range of lamp powers. Specific versions are optimized for 230 V and 110 V mains supplies. The product family integrates full CFL controller functionality with high voltage half-bridge transistors. All products in the UBA2024 family are pin-to-pin compatible enabling a single application design covering a wide range of power ratings.

The IC features a soft start function, an adjustable internal oscillator and an internal drive function with a high-voltage level shifter for driving the half-bridge.

To guarantee an accurate 50 % duty cycle, the oscillator signal is passed through a divider before being fed to the output drivers.

### 2. Features and benefits

---

- The common feature set includes:
  - ◆ high power efficiency
  - ◆ a high integration level with low component counts enabling small form factor electronic ballast
  - ◆ integrated bootstrap diode
  - ◆ soft start function
  - ◆ minimum glow time control
  - ◆ integrated low-voltage supply
  - ◆ adjustable operating frequency as a result of the embedded oscillator
  - ◆ an accurate 50 % duty cycle provided by an embedded oscillator signal
  - ◆ integrated half-bridge power transistors
  - ◆ an internal drive function with a high-voltage level shifter up to 550 V (300 V for the UBA2024BP and UBA2024BT)

### 3. Applications

---

- Driver for any kind of half-bridge configured load up to 23 W, provided that the maximum junction temperature is not exceeded
- Designed for electronically self-ballasted CFL lamps



### 4. Ordering information

Table 1. Ordering information

Type number	Package		Version
	Name	Description	
UBA2024P <sup>[1]</sup>	DIP8	plastic dual in-line package; 8 leads (300 mil)	SOT97-1
UBA2024T <sup>[1]</sup>	SO14	plastic small outline package; 14 leads; body width 3.9 mm	SOT108-1
UBA2024AP <sup>[2]</sup>	DIP8	plastic dual in-line package; 8 leads (300 mil)	SOT97-1
UBA2024AT <sup>[3]</sup>	SO14	plastic small outline package; 14 leads; body width 3.9 mm	SOT108-1
UBA2024BP <sup>[4]</sup>	DIP8	plastic dual in-line package; 8 leads (300 mil)	SOT97-1
UBA2024BT <sup>[4]</sup>	SO14	plastic small outline package; 14 leads; body width 3.9 mm	SOT108-1

- [1] For this type number,  $R_{DS(on)} = 9 \Omega$  and  $I_{SAT} = 900 \text{ mA}$ .
- [2] For this type number,  $R_{DS(on)} = 6 \Omega$  and  $I_{SAT} = 1350 \text{ mA}$ .
- [3] For this type number,  $R_{DS(on)} = 6.4 \Omega$  and  $I_{SAT} = 1200 \text{ mA}$ .
- [4] For this type number,  $R_{DS(on)} = 2 \Omega$  and  $I_{SAT} = 2500 \text{ mA}$ .

### 5. Block diagram

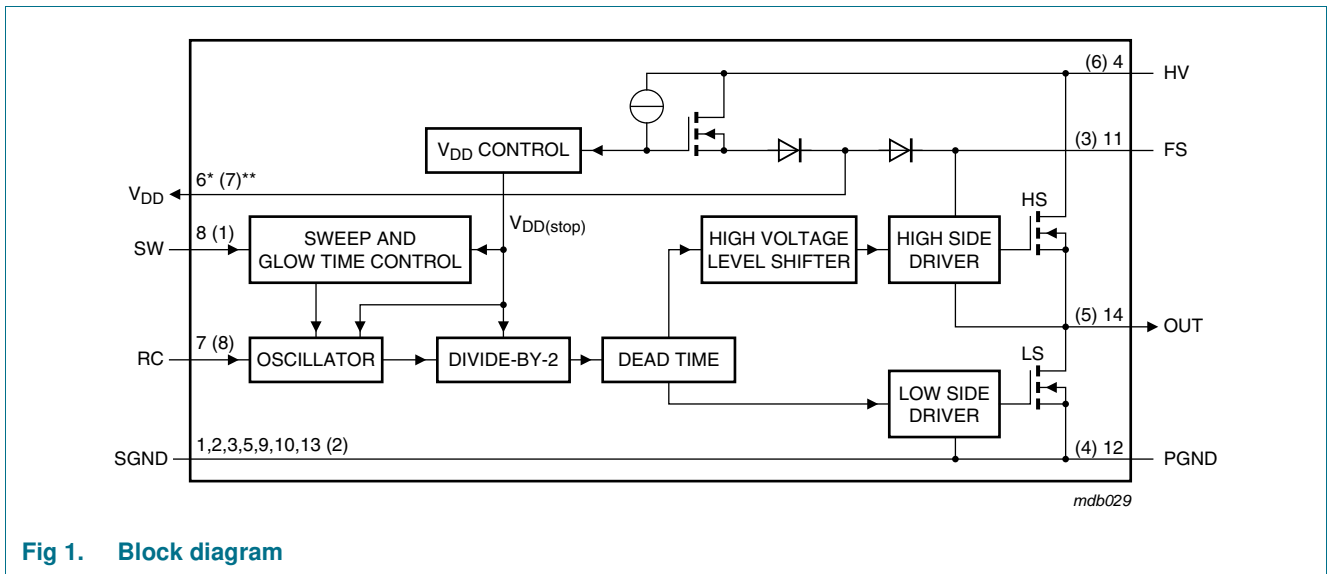
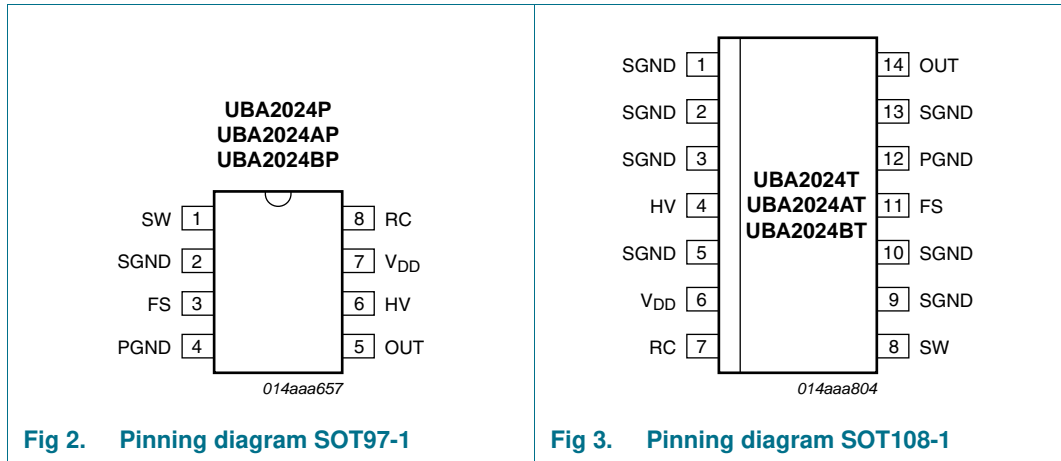

Fig 1. Block diagram

## 6. Pinning information

### 6.1 Pinning



### 6.2 Pin description

**Table 2. Pin description**

Symbol	Pin SOT97-1	Pin SOT108-1	Description
SW	1	8	sweep timing input
SGND	2	1, 2, 3, 5, 9, 10, 13	signal ground
FS	3	11	high-side floating supply output
PGND	4	12	power ground
OUT	5	14	half-bridge output
HV	6	4	high-voltage supply
V <sub>DD</sub>	7	6	internal low-voltage supply output
RC	8	7	internal oscillator input

## 7. Functional description

### 7.1 Supply voltage

The UBA2024 does not require an external low-voltage supply as the mains supply voltage applied to pin HV powers it. The IC derives its own low supply voltage from this for its internal circuitry.

### 7.2 Start-up state

With an increase of the supply voltage on pin HV, the IC enters the start-up state. In the start-up state the high-side power transistor is not conducting and the low-side power transistor is switched on. The internal circuit is reset and the capacitors on the bootstrap pin FS and low-voltage supply pin V<sub>DD</sub> are charged. Pins RC and SW are switched to ground. The start-up state is defined until V<sub>DD</sub> = V<sub>DD(startup)</sub>.

### 7.3 Sweep mode

The IC enters the sweep mode when the voltage on pin V<sub>DD</sub> > V<sub>DD(startup)</sub>. The capacitor on pin SW is charged by I<sub>SW</sub> and the half-bridge circuit starts oscillating. The circuit enters the start-up state again when the voltage on pin V<sub>DD</sub> < V<sub>DD(stop)</sub>.

The sweep time (t<sub>sweep</sub>) is determined by the charge current (I<sub>ch(sw)</sub>) and the external capacitor (C<sub>SW</sub>). Typical the total sweep time set by C<sub>SW</sub> is:

$$t_{sweep} = C_{SW} (nF) \times 10.3 \text{ ms} \quad (1)$$

During the sweep time the current flowing through the lamp electrodes performs some preheating of the filaments. See [Figure 5](#).

### 7.4 Reset

A DC reset circuit is incorporated in the high-side driver. The high-side transistor is switched off when the voltage on pin FS is below the high-side lockout voltage V<sub>float(UVLO)</sub>.

### 7.5 Oscillation

The oscillation is based upon the 555-timer function. A self oscillating circuit is made with the external resistor R<sub>OSC</sub> and the capacitor C<sub>OSC</sub> (see [Figure 4](#)).

To realize an accurate 50 % duty cycle, an internal divider is used. This reduces the bridge frequency to half the oscillator frequency.

The output voltage of the bridge will change at the falling edge of the signal on pin RC. The design equation for the half-bridge frequency is:

$$f_{osc} = \frac{I}{k \times R_{OSC} \times C_{OSC}} \quad (2)$$

An overview of the oscillator signal, internal LS and HS drive signals and the output is given in [Figure 4](#).

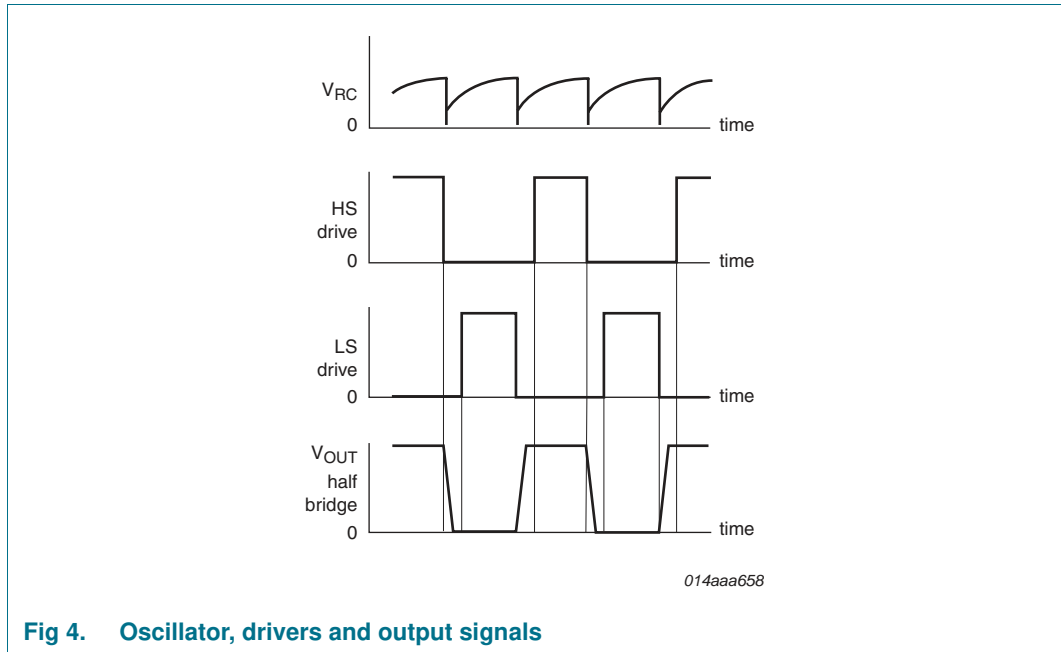

**Fig 4. Oscillator, drivers and output signals**

When entering the sweep mode ( $V_{SW} = 0\text{ V}$ ), the bridge oscillator starts at 2.5 times the nominal bridge frequency and sweeps down to the nominal frequency (bridge), set by  $R_{OSC}$  and  $C_{OSC}$ . During the sweep mode the amplitude of the RC oscillator on pin RC, will swing between  $V_{trip(osc)low}$  and  $V_{SW} + 0.4V_{trip(osc)high}$ . The amplitude of the RC oscillator will continue to increase until  $V_{SW} + 0.4V_{trip(osc)high} = V_{trip(osc)high}$ , this determines the end of the sweep time. The voltage on pin SW however will continue to rise until it reaches supply voltage level.

During this continuous decrease in frequency, the circuit approaches the resonance frequency of the load, and this causes a high voltage across the load, which ignites the lamp. The sweep to resonance time should be much larger than the settling time of the supply voltage on pin HV, to guarantee that the full high-voltage is present at the moment of ignition. See [Figure 5](#).

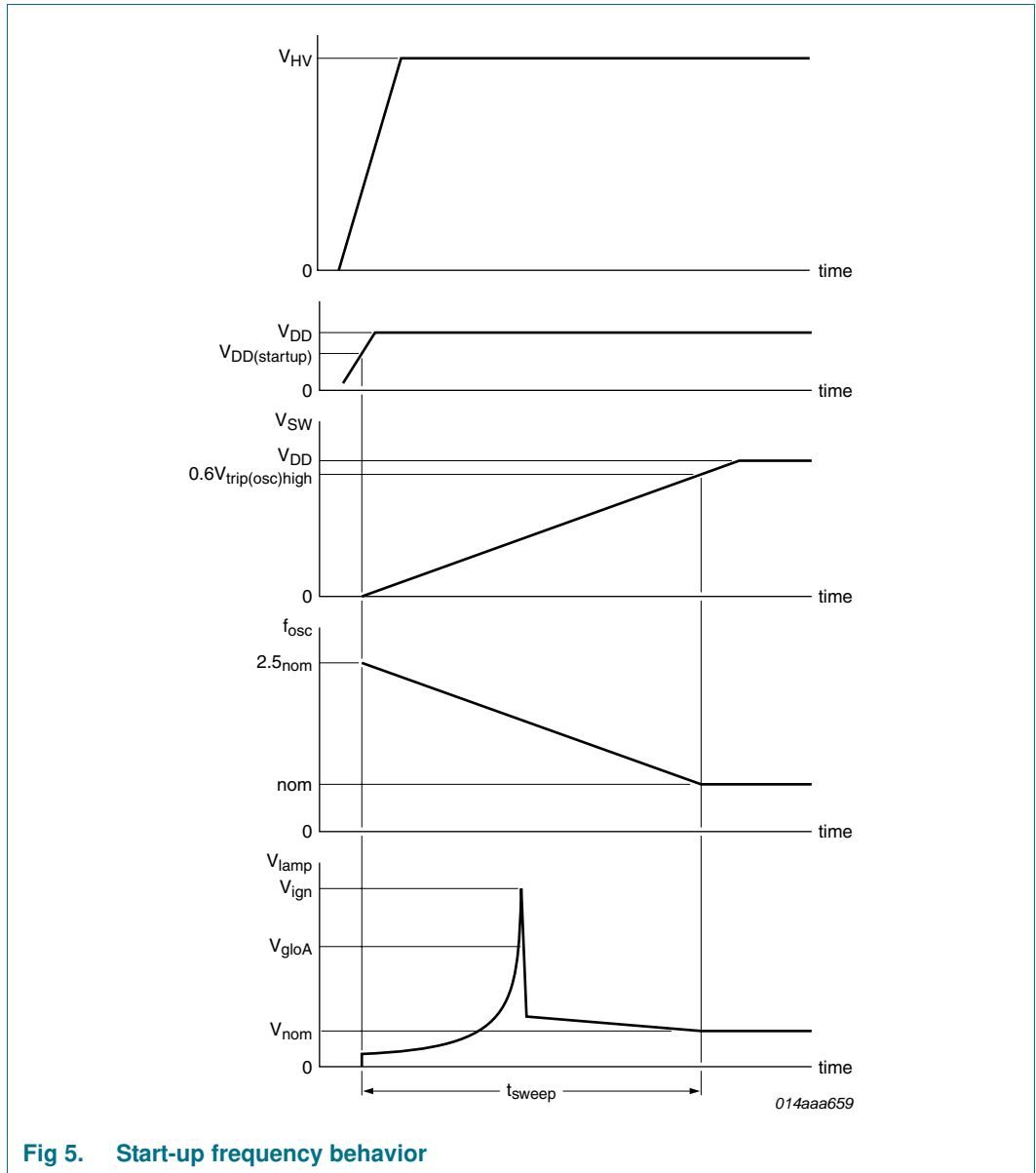

Fig 5. Start-up frequency behavior

### 7.6 Non-overlap time

The non-overlap time is defined as the time when both MOSFETs are not conducting. The non-overlap time is fixed internally.

## 8. Limiting values

**Table 3. Limiting values**

In accordance with the Absolute Maximum Rating System (IEC 60134).

Symbol	Parameter	Conditions	Min	Max	Unit	
V <sub>HV</sub>	voltage on pin HV	normal operation				
		UBA2024P	-	373	V	
		UBA2024AP	-	373	V	
		UBA2024T	-	373	V	
		UBA2024AT	-	373	V	
		UBA2024BP	-	187	V	
		UBA2024BT	-	187	V	
		mains transients during 0.5 s				
		UBA2024P	-	550	V	
		UBA2024AP	-	550	V	
		UBA2024T	-	550	V	
		UBA2024AT	-	550	V	
		UBA2024BP	-	300	V	
		UBA2024BT	-	300	V	
V <sub>FS</sub>	voltage on pin FS		V <sub>HV</sub>	V <sub>HV</sub> + 14	V	
V <sub>DD</sub>	supply voltage	low voltage; DC supply	0	14	V	
I <sub>DD</sub>	supply current	low voltage; peak value is internally limited; T <sub>amb</sub> = 25 °C	0	5	mA	
V <sub>PGND</sub>	voltage on pin PGND	referenced to SGND	-1	+1	V	
V <sub>RC</sub>	voltage on pin RC	I <sub>RC</sub> < 1 mA	0	V <sub>DD</sub>	V	
V <sub>SW</sub>	voltage on pin SW	I <sub>SW</sub> < 1 mA	0	V <sub>DD</sub>	V	
SR	slew rate	pin OUT; repetitive	-4	+4	V/ns	
T <sub>j</sub>	junction temperature		[1] -40	+150	°C	
T <sub>amb</sub>	ambient temperature		-40	+150	°C	
T <sub>stg</sub>	storage temperature		-55	+150	°C	

[1] The maximum junction temperature must not be exceeded.

## 9. Thermal characteristics

**Table 4. Thermal characteristics**

Symbol	Parameter	Conditions	Typ	Unit
R <sub>th(j-a)</sub>	thermal resistance from junction to ambient	in free air	[1]	
		SO14 package	95	K/W
		DIP8 package	95	K/W
R <sub>th(j-c)</sub>	thermal resistance from junction to case	in free air	[1]	
		SO14 package	8	K/W
		DIP8 package	16	K/W

[1] In accordance with IEC 60747-1

## 10. Characteristics

**Table 5. Characteristics**

$T_j = 25\text{ °C}$ ; all voltages are measured with respect to SGND; positive currents flow into the IC.

Symbol	Parameter	Conditions	Min	Typ	Max	Unit
<b>High-voltage supply</b>						
$V_{HV}$	voltage on pin HV	mains transients during 0.5 s; $I_{HV} < 30\ \mu\text{A}$				
		UBA2024P	0	-	550	V
		UBA2024AP	0	-	550	V
		UBA2024T	0	-	550	V
		UBA2024AT	0	-	550	V
		UBA2024BP	0	-	250	V
		UBA2024BT	0	-	250	V
$V_{FS}$	voltage on pin FS	mains transients during 0.5 s; $I_{HV} < 30\ \mu\text{A}$				
		UBA2024P	0	-	564	V
		UBA2024AP	0	-	564	V
		UBA2024T	0	-	564	V
		UBA2024AT	0	-	564	V
		UBA2024BP	0	-	264	V
		UBA2024BT	0	-	264	V
<b>Low-voltage supply</b>						
$V_{DD}$	supply voltage	$V_{HV} = 100\text{ V}$ ; $R_{osc} = \infty$ ; $V_{SW} = V_{DD}$ ; $V_{RC} = 0\text{ V}$	11.4	12.5	13.3	V
<b>Start-up state</b>						
$I_{HV}$	current on pin HV	$V_{HV} = 100\text{ V}$ ; $R_{osc} = \infty$ ; $V_{SW} = V_{DD}$ ; $V_{RC} = 0\text{ V}$	-	-	0.39	mA
$V_{DD(\text{startup})}$	start-up supply voltage		10	11	12	V
$V_{DD(\text{stop})}$	stop supply voltage		8	8.5	9	V
$V_{DD(\text{hys})}$	hysteresis of supply voltage		2	2.5	3	V



**Table 5. Characteristics ...continued**

$T_j = 25\text{ °C}$ ; all voltages are measured with respect to SGND; positive currents flow into the IC.

Symbol	Parameter	Conditions	Min	Typ	Max	Unit
<b>Output stage</b>						
$R_{on}$	on-state resistance	HS transistor; $V_{HV} = 310\text{ V}$ ; $I_D = 100\text{ mA}$				
		UBA2024P	-	9.7	11	$\Omega$
		UBA2024T	-	9.7	11	$\Omega$
		UBA2024AP	-	6.5	7.4	$\Omega$
		UBA2024AT	-	7.0	8.0	$\Omega$
		HS transistor; $V_{HV} = 160\text{ V}$ ; $I_D = 100\text{ mA}$				
		UBA2024BP	-	2.0	2.35	$\Omega$
		UBA2024BT	-	2.0	2.35	$\Omega$
		LS transistor; $I_D = 100\text{ mA}$				
		UBA2024P	-	8.5	9.4	$\Omega$
		UBA2024T	-	8.5	9.4	$\Omega$
		UBA2024AP	-	5.7	6.3	$\Omega$
		UBA2024AT	-	6.2	6.9	$\Omega$
		UBA2024BP	-	2.3	2.55	$\Omega$
UBA2024BT	-	2.3	2.55	$\Omega$		
$V_F$	forward voltage	HS; $I_F = 200\text{ mA}$	-	-	2.0	V
		LS; $I_F = 200\text{ mA}$	-	-	2.0	V
		bootstrap diode; $I_F = 1\text{ mA}$	0.7	1.0	1.3	V
$I_{Dsat}$	drain saturation current	HS; $V_{DS} = 30\text{ V}$ ; $T_j \leq 125\text{ °C}$ ; $V_{HV} = 310\text{ V}$				
		UBA2024P	900	-	-	mA
		UBA2024AP	1350	-	-	mA
		UBA2024T	900	-	-	mA
		UBA2024AT	1200	-	-	mA
		HS; $V_{DS} = 30\text{ V}$ ; $T_j \leq 125\text{ °C}$ ; $V_{HV} = 160\text{ V}$				
		UBA2024BP	2500	-	-	mA
		UBA2024BT	2500	-	-	mA
		LS; $V_{DS} = 30\text{ V}$ ; $T_j \leq 125\text{ °C}$				
		UBA2024P	900	-	-	mA
		UBA2024AP	1350	-	-	mA
		UBA2024T	900	-	-	mA
		UBA2024AT	1200	-	-	mA
		UBA2024BP	2500	-	-	mA
UBA2024BT	2500	-	-	mA		
$t_{no}$	non-overlap time		1	1.35	1.7	$\mu\text{s}$
$V_{float(UVLO)}$	undervoltage lockout floating voltage		3.6	4.2	4.8	V

**Table 5. Characteristics ...continued** $T_j = 25\text{ °C}$ ; all voltages are measured with respect to SGND; positive currents flow into the IC.

Symbol	Parameter	Conditions	Min	Typ	Max	Unit
$I_{FS}$	current on pin FS	$V_{HV} = 310\text{ V}$ ; $V_{FS} = 12.2\text{ V}$				
		UBA2024P, UBA2024T	10	14	18	$\mu\text{A}$
		UBA2024AP, UBA2024AT	10	14	18	$\mu\text{A}$
		$V_{HV} = 160\text{ V}$ ; $V_{FS} = 12.2\text{ V}$				
		UBA2024BP, UBA2024BT	10	14	18	$\mu\text{A}$
<b>Internal oscillator</b>						
$f_{osc}$	oscillator frequency	$V_{SW} = 0\text{ V}$	-	150	-	kHz
		$V_{SW} = V_{DD}$	-	-	60	kHz
		operating; nominal; $R_{OSC} = 100\text{ k}\Omega$ ; $C_{OSC} = 220\text{ pF}$ ; $V_{SW} = V_{DD}$	40.05	41.32	42.68	kHz
$\Delta f_{osc}/f_{osc}$	relative oscillator frequency variation	$R_{OSC} = 100\text{ k}\Omega$ ; $C_{OSC} = 220\text{ pF}$ ; $-20\text{ °C} \leq T_j \leq +150\text{ °C}$	-	2	-	%
$K_H$	high-level trip point factor		0.382	0.395	0.408	
$V_{trip(osc)high}$	high oscillator trip voltage	$V_{trip(osc)high} = K_H \times V_{DD}$	4.58	4.94	5.29	V
$K_L$	low-level trip point factor		0.030	0.033	0.038	
$V_{trip(osc)low}$	low oscillator trip voltage	$V_{trip(osc)low} = K_L \times V_{DD}$	0.367	0.413	0.483	V
$K_{osc}$	oscillator constant	$R_{OSC} = 100\text{ k}\Omega$ ; $C_{OSC} = 220\text{ pF}$	1.065	1.1	1.35	V
<b>Sweep function</b>						
$I_{ch(sweep)}$	sweep charge current	$V_{SW} = 0\text{ V}$	215	280	345	nA
$t_{sweep}$	sweep time	$C_{SW} = 33\text{ nF}$ ; $V_{DD} = 12.2\text{ V}$	0.28	0.35	0.45	s

## 11. Electrostatic discharge

**Table 6. ElectroStatic Discharge (ESD) overview**

Model	Class	JEDEC classification criteria
ESDH (human body model)	1C	pass at ESD pulse 1000 V
		fail at ESD pulse 2000 V
ESDC (charged device model)	C2	pass at ESD pulse 200 V
		fail at ESD pulse 500 V
ESDM (machine model)	B	pass at $200\text{ V} \geq \text{ESD pulse} < 400\text{ V}$

## 12. Application information

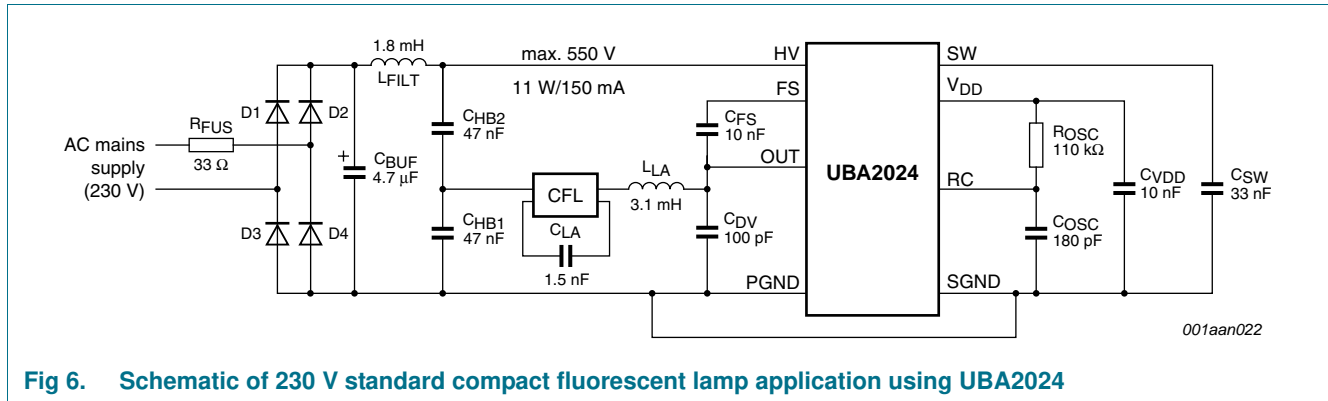

Fig 6. Schematic of 230 V standard compact fluorescent lamp application using UBA2024

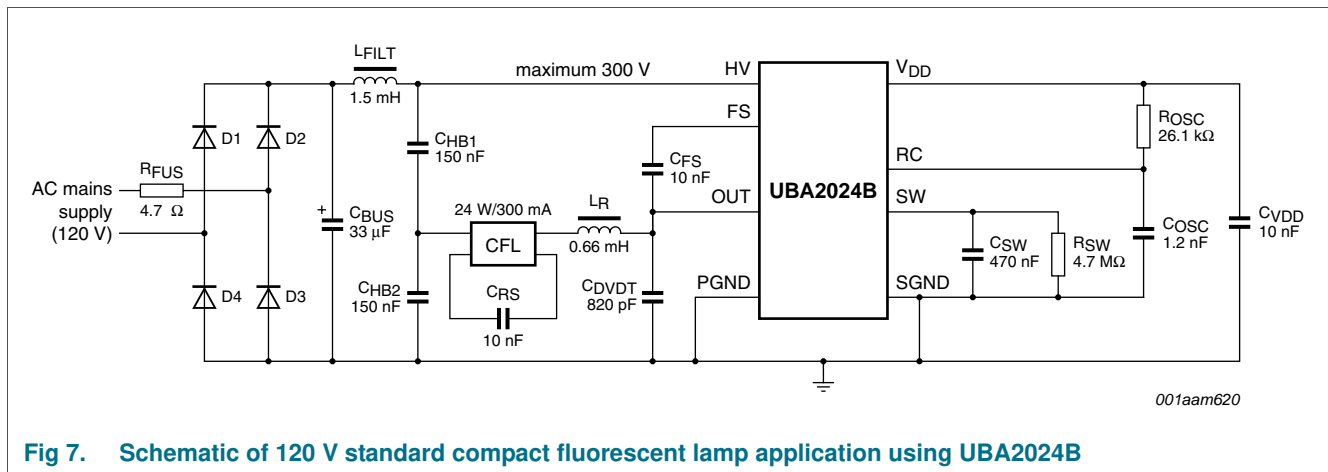

Fig 7. Schematic of 120 V standard compact fluorescent lamp application using UBA2024B

### 13. Package outline

DIP8: plastic dual in-line package; 8 leads (300 mil)

SOT97-1

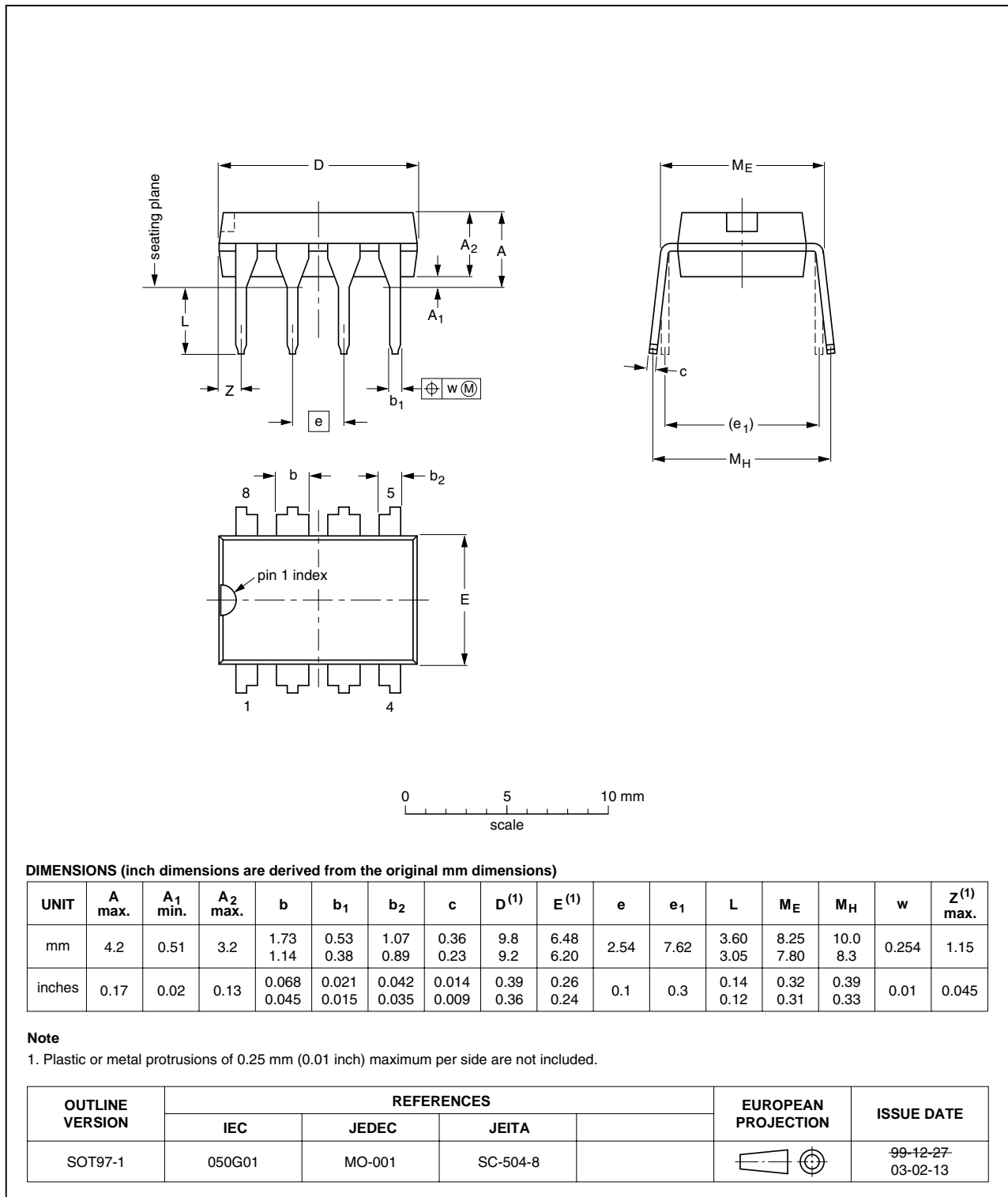

Fig 8. Package outline SOT97-1 (DIP8)

SO14: plastic small outline package; 14 leads; body width 3.9 mm

SOT108-1

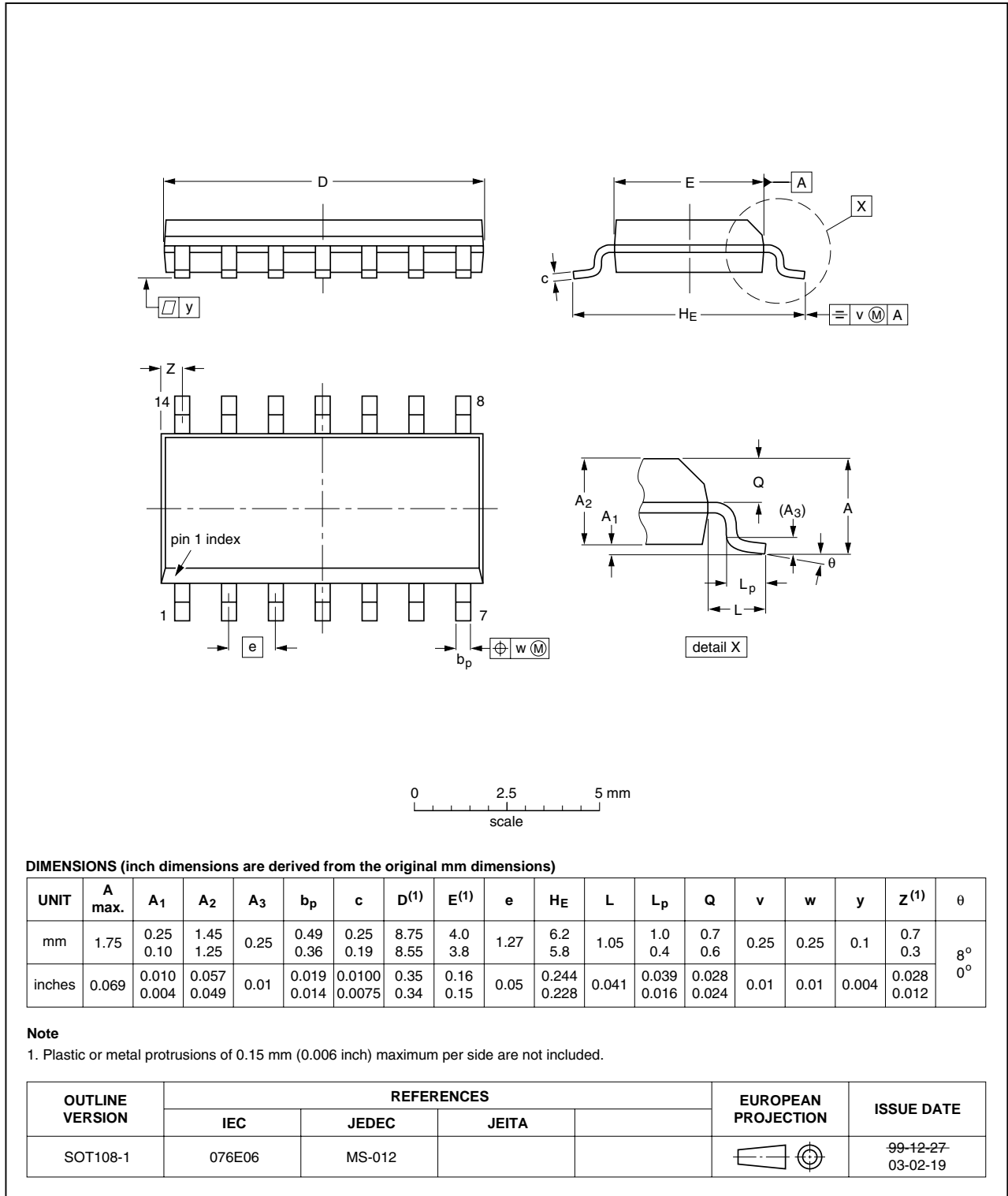

Fig 9. Package outline SOT108-1 (SO14)

## 14. Revision history

Table 7. Revision history

Document ID	Release date	Data sheet status	Change notice	Supersedes
UBA2024 v.6.2	20101101	Product data sheet	-	UBA2024 v.5
Modifications:		<ul style="list-style-type: none"> <li>• <a href="#">Figure 5 on page 6</a> has been changed.</li> <li>• The glow time section has been removed.</li> <li>• ESD values have been removed from <a href="#">Table 3 “Limiting values” on page 7</a>, added in to <a href="#">Table 6 “ElectroStatic Discharge (ESD) overview” on page 10</a> and one error corrected.</li> <li>• <a href="#">Table 3 “Limiting values” on page 7</a>: table notes 2 and 3 have been removed.</li> <li>• <a href="#">Table 5 “Characteristics” on page 8</a>: <ul style="list-style-type: none"> <li>– <math>V_{DD}</math> supply voltage minimum value has been changed.</li> <li>– <math>V_F</math> forward voltage HS maximum value has been changed.</li> <li>– <math>K_L</math> low-level trip point factor maximum value has been changed.</li> <li>– <math>V_{trip(osc)low}</math> low oscillator trip voltage maximum value has been changed.</li> </ul> </li> <li>• <a href="#">Figure 6 on page 11</a> have been changed.</li> </ul>		
UBA2024 v.5	20100916	Product data sheet	-	UBA2024 v.4
UBA2024 v.4	20090917	Product data sheet	-	UBA2024 v.3
UBA2024 v.3	081016	Product data sheet	-	UBA2024 v.2
UBA2024 v.2	040203	Product data sheet	-	UBA2024 v.1
UBA2024 v.1	030813	Product data sheet	-	-

## 15. Legal information

### 15.1 Data sheet status

Document status <sup>[1][2]</sup>	Product status <sup>[3]</sup>	Definition
Objective [short] data sheet	Development	This document contains data from the objective specification for product development.
Preliminary [short] data sheet	Qualification	This document contains data from the preliminary specification.
Product [short] data sheet	Production	This document contains the product specification.

[1] Please consult the most recently issued document before initiating or completing a design.

[2] The term 'short data sheet' is explained in section "Definitions".

[3] The product status of device(s) described in this document may have changed since this document was published and may differ in case of multiple devices. The latest product status information is available on the Internet at URL <http://www.nxp.com>.

### 15.2 Definitions

**Draft** — The document is a draft version only. The content is still under internal review and subject to formal approval, which may result in modifications or additions. NXP Semiconductors does not give any representations or warranties as to the accuracy or completeness of information included herein and shall have no liability for the consequences of use of such information.

**Short data sheet** — A short data sheet is an extract from a full data sheet with the same product type number(s) and title. A short data sheet is intended for quick reference only and should not be relied upon to contain detailed and full information. For detailed and full information see the relevant full data sheet, which is available on request via the local NXP Semiconductors sales office. In case of any inconsistency or conflict with the short data sheet, the full data sheet shall prevail.

**Product specification** — The information and data provided in a Product data sheet shall define the specification of the product as agreed between NXP Semiconductors and its customer, unless NXP Semiconductors and customer have explicitly agreed otherwise in writing. In no event however, shall an agreement be valid in which the NXP Semiconductors product is deemed to offer functions and qualities beyond those described in the Product data sheet.

### 15.3 Disclaimers

**Limited warranty and liability** — Information in this document is believed to be accurate and reliable. However, NXP Semiconductors does not give any representations or warranties, expressed or implied, as to the accuracy or completeness of such information and shall have no liability for the consequences of use of such information.

In no event shall NXP Semiconductors be liable for any indirect, incidental, punitive, special or consequential damages (including - without limitation - lost profits, lost savings, business interruption, costs related to the removal or replacement of any products or rework charges) whether or not such damages are based on tort (including negligence), warranty, breach of contract or any other legal theory.

Notwithstanding any damages that customer might incur for any reason whatsoever, NXP Semiconductors' aggregate and cumulative liability towards customer for the products described herein shall be limited in accordance with the *Terms and conditions of commercial sale* of NXP Semiconductors.

**Right to make changes** — NXP Semiconductors reserves the right to make changes to information published in this document, including without limitation specifications and product descriptions, at any time and without notice. This document supersedes and replaces all information supplied prior to the publication hereof.

**Suitability for use** — NXP Semiconductors products are not designed, authorized or warranted to be suitable for use in life support, life-critical or safety-critical systems or equipment, nor in applications where failure or

malfunction of an NXP Semiconductors product can reasonably be expected to result in personal injury, death or severe property or environmental damage. NXP Semiconductors accepts no liability for inclusion and/or use of NXP Semiconductors products in such equipment or applications and therefore such inclusion and/or use is at the customer's own risk.

**Applications** — Applications that are described herein for any of these products are for illustrative purposes only. NXP Semiconductors makes no representation or warranty that such applications will be suitable for the specified use without further testing or modification.

Customers are responsible for the design and operation of their applications and products using NXP Semiconductors products, and NXP Semiconductors accepts no liability for any assistance with applications or customer product design. It is customer's sole responsibility to determine whether the NXP Semiconductors product is suitable and fit for the customer's applications and products planned, as well as for the planned application and use of customer's third party customer(s). Customers should provide appropriate design and operating safeguards to minimize the risks associated with their applications and products.

NXP Semiconductors does not accept any liability related to any default, damage, costs or problem which is based on any weakness or default in the customer's applications or products, or the application or use by customer's third party customer(s). Customer is responsible for doing all necessary testing for the customer's applications and products using NXP Semiconductors products in order to avoid a default of the applications and the products or of the application or use by customer's third party customer(s). NXP does not accept any liability in this respect.

**Limiting values** — Stress above one or more limiting values (as defined in the Absolute Maximum Ratings System of IEC 60134) will cause permanent damage to the device. Limiting values are stress ratings only and (proper) operation of the device at these or any other conditions above those given in the Recommended operating conditions section (if present) or the Characteristics sections of this document is not warranted. Constant or repeated exposure to limiting values will permanently and irreversibly affect the quality and reliability of the device.

**Terms and conditions of commercial sale** — NXP Semiconductors products are sold subject to the general terms and conditions of commercial sale, as published at <http://www.nxp.com/profile/terms>, unless otherwise agreed in a valid written individual agreement. In case an individual agreement is concluded only the terms and conditions of the respective agreement shall apply. NXP Semiconductors hereby expressly objects to applying the customer's general terms and conditions with regard to the purchase of NXP Semiconductors products by customer.

**No offer to sell or license** — Nothing in this document may be interpreted or construed as an offer to sell products that is open for acceptance or the grant, conveyance or implication of any license under any copyrights, patents or other industrial or intellectual property rights.

**Export control** — This document as well as the item(s) described herein may be subject to export control regulations. Export might require a prior authorization from national authorities.

**Non-automotive qualified products** — Unless this data sheet expressly states that this specific NXP Semiconductors product is automotive qualified, the product is not suitable for automotive use. It is neither qualified nor tested in accordance with automotive testing or application requirements. NXP Semiconductors accepts no liability for inclusion and/or use of non-automotive qualified products in automotive equipment or applications.

In the event that customer uses the product for design-in and use in automotive applications to automotive specifications and standards, customer (a) shall use the product without NXP Semiconductors' warranty of the product for such automotive applications, use and specifications, and (b) whenever customer uses the product for automotive applications beyond

NXP Semiconductors' specifications such use shall be solely at customer's own risk, and (c) customer fully indemnifies NXP Semiconductors for any liability, damages or failed product claims resulting from customer design and use of the product for automotive applications beyond NXP Semiconductors' standard warranty and NXP Semiconductors' product specifications.

## 15.4 Trademarks

Notice: All referenced brands, product names, service names and trademarks are the property of their respective owners.

## 16. Contact information

For more information, please visit: <http://www.nxp.com>

For sales office addresses, please send an email to: [salesaddresses@nxp.com](mailto:salesaddresses@nxp.com)



## 17. Contents

<b>1</b>	<b>General description</b> .....	<b>1</b>
<b>2</b>	<b>Features and benefits</b> .....	<b>1</b>
<b>3</b>	<b>Applications</b> .....	<b>1</b>
<b>4</b>	<b>Ordering information</b> .....	<b>2</b>
<b>5</b>	<b>Block diagram</b> .....	<b>2</b>
<b>6</b>	<b>Pinning information</b> .....	<b>3</b>
6.1	Pinning .....	3
6.2	Pin description .....	3
<b>7</b>	<b>Functional description</b> .....	<b>4</b>
7.1	Supply voltage .....	4
7.2	Start-up state .....	4
7.3	Sweep mode .....	4
7.4	Reset .....	4
7.5	Oscillation .....	4
7.6	Non-overlap time .....	6
<b>8</b>	<b>Limiting values</b> .....	<b>7</b>
<b>9</b>	<b>Thermal characteristics</b> .....	<b>7</b>
<b>10</b>	<b>Characteristics</b> .....	<b>8</b>
<b>11</b>	<b>Electrostatic discharge</b> .....	<b>10</b>
<b>12</b>	<b>Application information</b> .....	<b>11</b>
<b>13</b>	<b>Package outline</b> .....	<b>12</b>
<b>14</b>	<b>Revision history</b> .....	<b>14</b>
<b>15</b>	<b>Legal information</b> .....	<b>15</b>
15.1	Data sheet status .....	15
15.2	Definitions .....	15
15.3	Disclaimers .....	15
15.4	Trademarks .....	16
<b>16</b>	<b>Contact information</b> .....	<b>16</b>
<b>17</b>	<b>Contents</b> .....	<b>17</b>

Please be aware that important notices concerning this document and the product(s) described herein, have been included in section 'Legal information'.

© NXP B.V. 2010.

All rights reserved.

For more information, please visit: <http://www.nxp.com>

For sales office addresses, please send an email to: [salesaddresses@nxp.com](mailto:salesaddresses@nxp.com)

Date of release: 1 November 2010

Document identifier: UBA2024