

*Advance Information*  
**SWITCHMODE™**  
**Ultrafast “E” Series Power Rectifier**

**Plastic TO–220 Package**

Features mesa epitaxial construction with glass passivation. Ideally suited high frequency switching power supplies; free wheeling diodes; polarity protection diodes; and inverters.

- 20 mJoules Avalanche Energy Guaranteed
- Ultrafast 50 Nanoseconds Recovery Time
- Stable, High Temperature, Glass Passivated Junction
- Monolithic Dual Die Construction.  
May be Paralleled for High Current Output.

**Mechanical Characteristics:**

- Case: Molded Epoxy
- Epoxy meets UL94, V<sub>O</sub> at 1/8
- Weight: 1.9 grams (approximately)
- Finish: All External Surfaces Corrosion Resistant and Terminal Leads are Readily Solderable
- Maximum Temperature of 260°C / 10 Seconds for Soldering
- Shipped in 50 Units per Plastic Tube
- Marking: H8100E

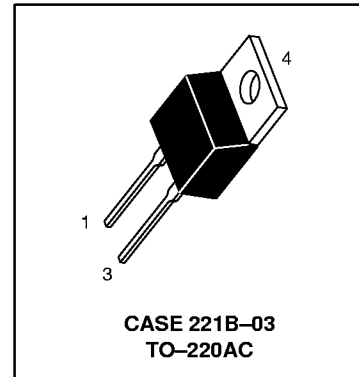
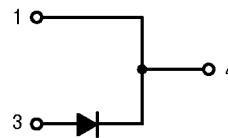

**MAXIMUM RATINGS**

Rating	Symbol	Value	Unit
Peak Repetitive Reverse Voltage Working Peak Reverse Voltage DC Blocking Voltage	V <sub>RRM</sub> V <sub>VRM</sub> V <sub>R</sub>	1000	V
Average Rectified Forward Current (At Rated V <sub>R</sub> , T <sub>C</sub> = 150°C)	I <sub>O</sub> Per Leg Per Package	4.0	A
Peak Repetitive Forward Current (At Rated V <sub>R</sub> , Square Wave, 20 kHz, T <sub>C</sub> = 150°C)	I <sub>FRM</sub> Per Leg	8.0	A
Non–Repetitive Peak Surge Current (Surge applied at rated load conditions, halfwave, single phase, 60 Hz)	I <sub>FSM</sub> Per Package	100	A
Storage / Operating Case Temperature	T <sub>stg</sub> , T <sub>C</sub>	–55 to +175	°C
Operating Junction Temperature	T <sub>J</sub>	–55 to +175	°C

**THERMAL CHARACTERISTICS**

Thermal Resistance — Junction–to–Case	Per Leg	R <sub>θJC</sub>	2.0	°C/W
---------------------------------------	---------	------------------	-----	------

**ELECTRICAL CHARACTERISTICS**

Rating	Symbol	Value		Unit
Maximum Instantaneous Forward Voltage (1), see Figure 2 (I <sub>F</sub> = 4.0 A) (I <sub>F</sub> = 8.0 A)	V <sub>F</sub> Per Leg	T <sub>J</sub> = 25°C	T <sub>J</sub> = 100°C	V
		2.2	1.8	
Maximum Instantaneous Reverse Current, see Figure 4 (V <sub>R</sub> = 1000 V) (V <sub>R</sub> = 500 V)	I <sub>R</sub> Per Leg	T <sub>J</sub> = 25°C	T <sub>J</sub> = 100°C	μA
		10	100	
		4.0	55	

(1) Pulse Test: Pulse Width ≤ 250 μs, Duty Cycle ≤ 2%.

This document contains information on a new product. Specifications and information herein are subject to change without notice.

SWITCHMODE is a trademark of Motorola, Inc.

# MURH8100E

## ELECTRICAL CHARACTERISTICS (continued)

Rating	Symbol	Value		Unit
Maximum Reverse Recovery Time (2) ( $V_R = 30\text{ V}$ , $I_F = 1.0\text{ A}$ , $di/dt = 50\text{ A}/\mu\text{s}$ ) ( $V_R = 30\text{ V}$ , $I_F = 8.0\text{ A}$ , $di/dt = 100\text{ A}/\mu\text{s}$ )  Typical $t_a @ 8.0\text{ (A)}$ Typical $t_b @ 8.0\text{ (A)}$	$t_{rr}$	$T_J = 25^\circ\text{C}$	$T_J = 125^\circ\text{C}$	ns
		50	80	
	$t_a$ $t_b$	38	41	ns
		16	23	
Typical Peak Reverse Recovery Current ( $V_R = 30\text{ V}$ , $I_F = 1.0\text{ A}$ , $di/dt = 50\text{ A}/\mu\text{s}$ ) ( $V_R = 30\text{ V}$ , $I_F = 8.0\text{ A}$ , $di/dt = 100\text{ A}/\mu\text{s}$ )	$I_{rm}$	$T_J = 25^\circ\text{C}$	$T_J = 125^\circ\text{C}$	A
		1.5	2.2	
Controlled Avalanche Energy (See Test Circuit in Figure 9)	Waval	20		mJ

(2)  $t_{rr}$  measured projecting from 25% of  $I_{RM}$  to ground.

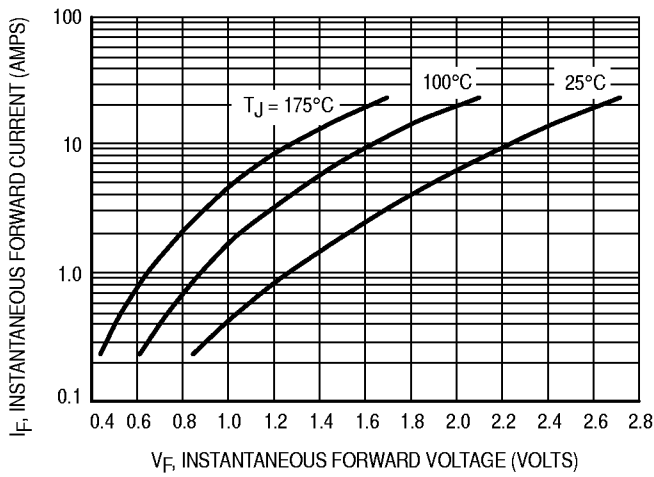

Figure 1. Typical Forward Voltage

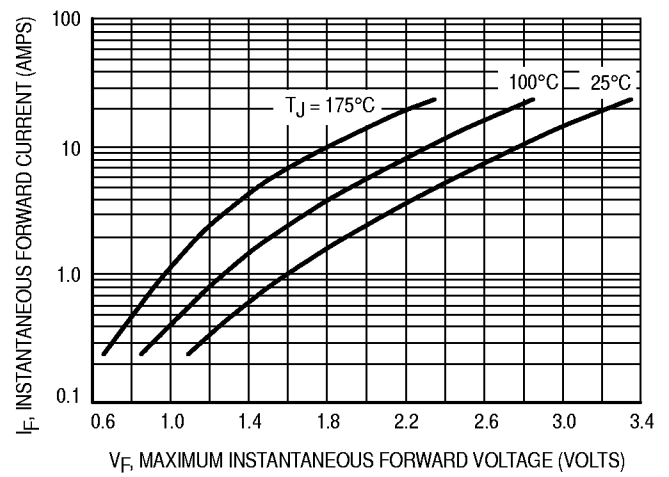

Figure 2. Maximum Forward Voltage

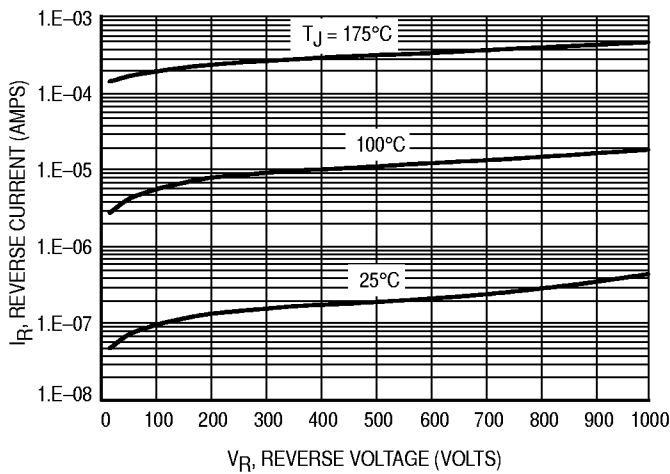

Figure 3. Typical Reverse Current

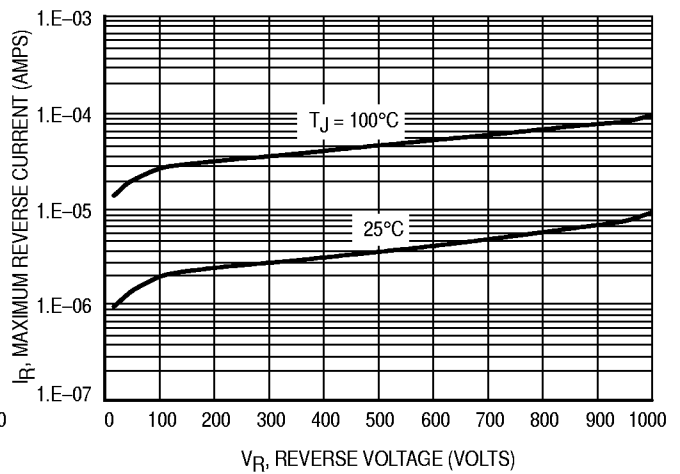

Figure 4. Maximum Reverse Current

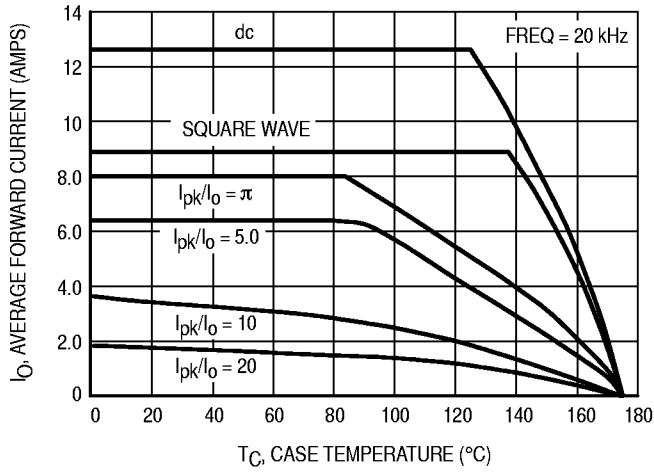

Figure 5. Current Derating, Per Leg

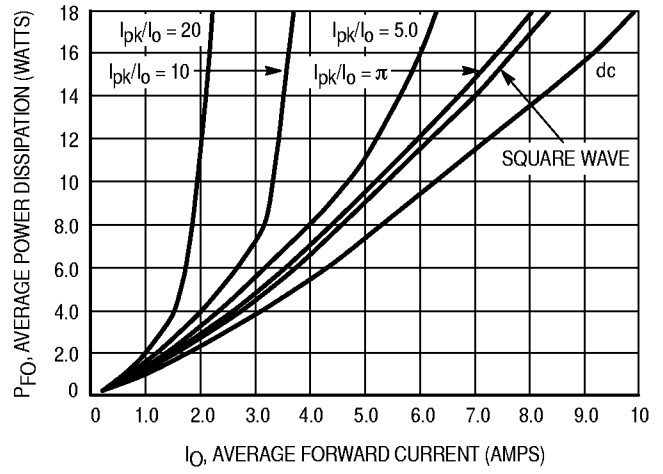

Figure 6. Forward Power Dissipation, Per Leg

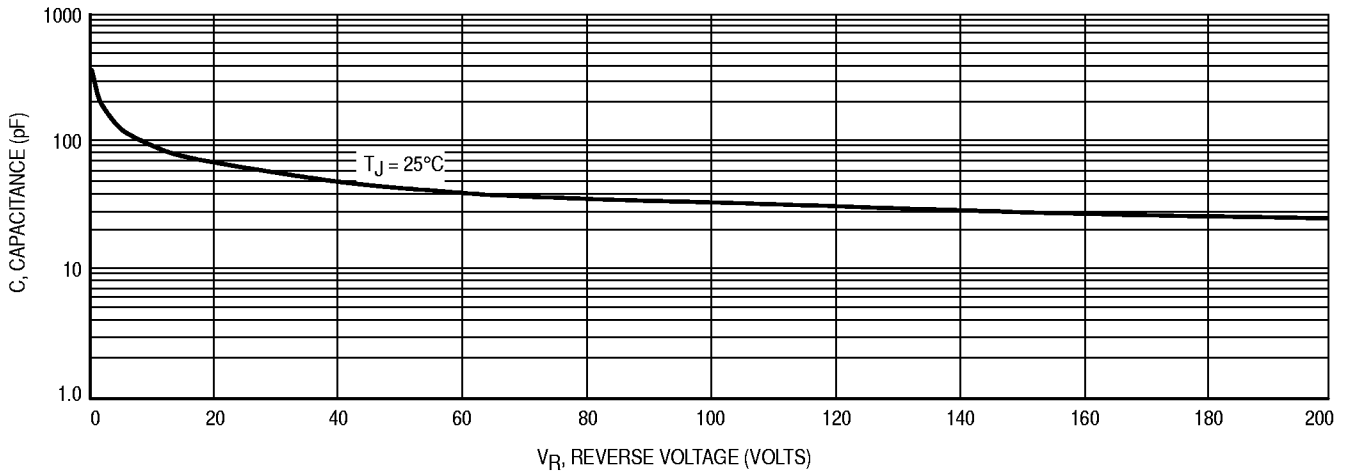

Figure 7. Capacitance

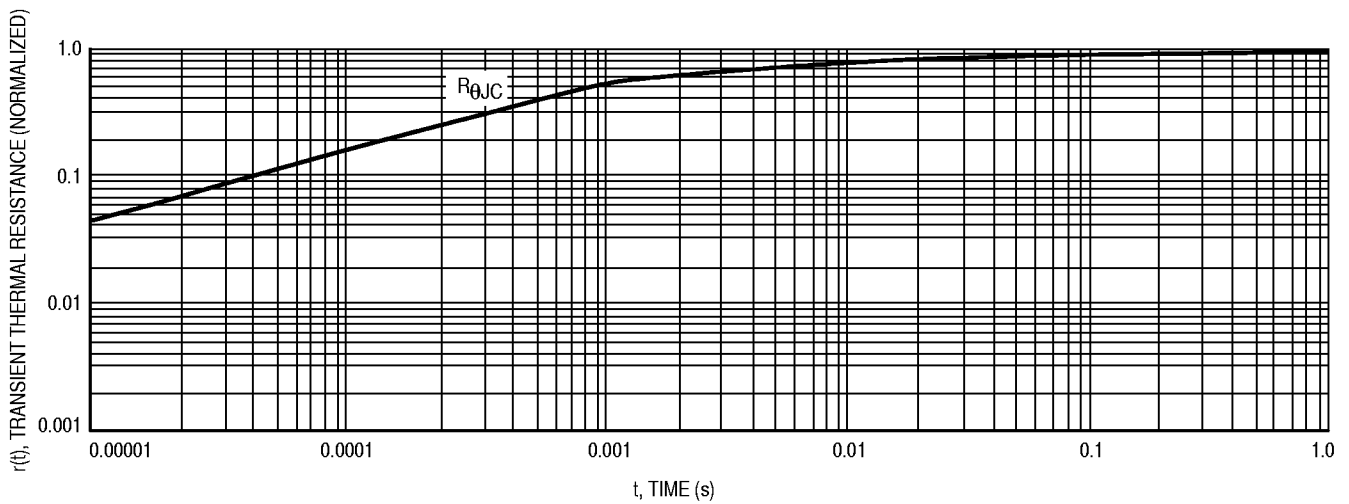

Figure 8. Thermal Response

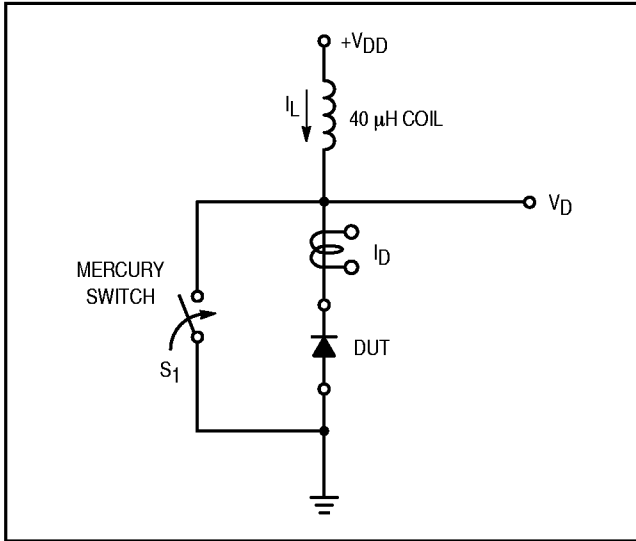

Figure 9. Test Circuit

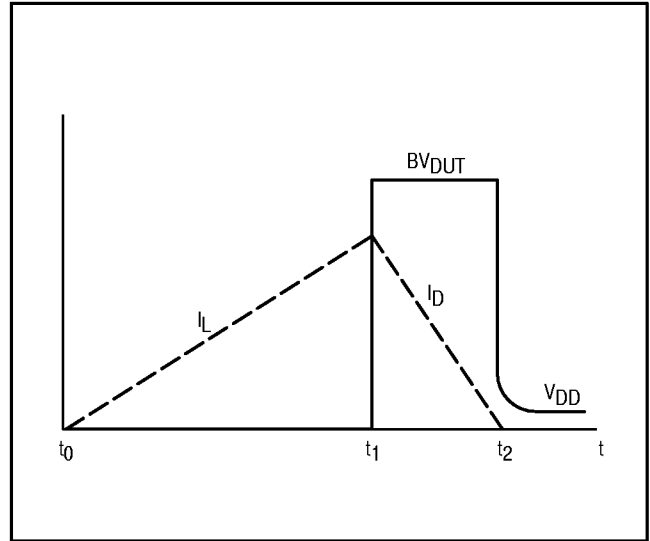

Figure 10. Current-Voltage Waveforms

The unclamped inductive switching circuit shown in Figure 9 was used to demonstrate the controlled avalanche capability of the new “E” series Ultrafast rectifiers. A mercury switch was used instead of an electronic switch to simulate a noisy environment when the switch was being opened.

When  $S_1$  is closed at  $t_0$  the current in the inductor  $I_L$  ramps up linearly; and energy is stored in the coil. At  $t_1$  the switch is opened and the voltage across the diode under test begins to rise rapidly, due to  $di/dt$  effects, when this induced voltage reaches the breakdown voltage of the diode, it is clamped at  $BV_{DUT}$  and the diode begins to conduct the full load current which now starts to decay linearly through the diode, and goes to zero at  $t_2$ .

By solving the loop equation at the point in time when  $S_1$  is opened; and calculating the energy that is transferred to the diode it can be shown that the total energy transferred is equal to the energy stored in the inductor plus a finite amount of energy from the  $V_{DD}$  power supply while the diode is in

breakdown (from  $t_1$  to  $t_2$ ) minus any losses due to finite component resistances. Assuming the component resistive elements are small Equation (1) approximates the total energy transferred to the diode. It can be seen from this equation that if the  $V_{DD}$  voltage is low compared to the breakdown voltage of the device, the amount of energy contributed by the supply during breakdown is small and the total energy can be assumed to be nearly equal to the energy stored in the coil during the time when  $S_1$  was closed, Equation (2).

The oscilloscope picture in Figure 11, shows the test circuit conducting a peak current of one ampere at a breakdown voltage of 1300 volts, and using Equation (2) the energy absorbed is approximately 20 mjoules.

Although it is not recommended to design for this condition, the new “E” series provides added protection against those unforeseen transient viruses that can produce unexplained random failures in unfriendly environments.

EQUATION (1):

$$W_{AVAIL} \approx \frac{1}{2} L I_{LPK}^2 \left( \frac{BV_{DUT}}{BV_{DUT} - V_{DD}} \right)$$

EQUATION (2):

$$W_{AVAIL} \approx \frac{1}{2} L I_{LPK}^2$$

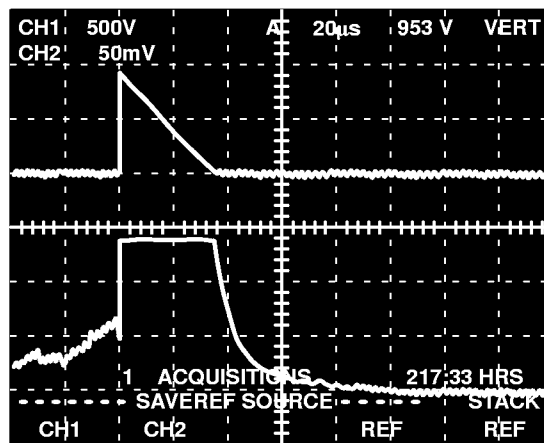

CHANNEL 2:

$I_L$   
0.5 AMPS/DIV.

CHANNEL 1:

$V_{DUT}$   
500 VOLTS/DIV.

TIME BASE:

20  $\mu$ s/DIV.

Figure 11. Current-Voltage Waveforms

PACKAGE DIMENSIONS

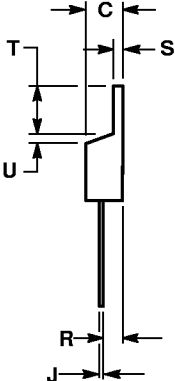
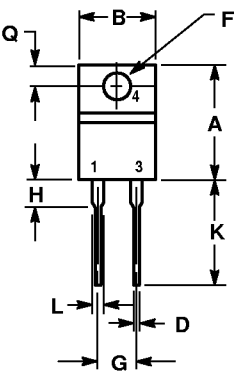

- NOTES:  
1. DIMENSIONING AND TOLERANCING PER ANSI Y14.5M, 1982.  
2. CONTROLLING DIMENSION: INCH.

DIM	INCHES		MILLIMETERS	
	MIN	MAX	MIN	MAX
A	0.595	0.620	15.11	15.75
B	0.380	0.405	9.65	10.29
C	0.160	0.190	4.06	4.82
D	0.025	0.035	0.64	0.89
F	0.142	0.147	3.61	3.73
G	0.190	0.210	4.83	5.33
H	0.110	0.130	2.79	3.30
J	0.018	0.025	0.46	0.64
K	0.500	0.562	12.70	14.27
L	0.045	0.060	1.14	1.52
Q	0.100	0.120	2.54	3.04
R	0.080	0.110	2.04	2.79
S	0.045	0.055	1.14	1.39
T	0.235	0.255	5.97	6.48
U	0.000	0.050	0.000	1.27

CASE 221B-04  
ISSUE C