

THIS DOCUMENT IS SUBJECT TO CHANGE WITHOUT NOTICE. IT IS CONFIDENTIAL AND A PROPERTY OF AMPHENOL LTW. DISCLOSURE TO THIRD PARTY HAS TO BE AUTHORIZED BY AMPHENOL LTW.

REV.	ECN NO.	DATE	SIGN	DESCRIPTION
A		2021/01/11	Xiaofeng	New Initial

(L Dimensions refer to table on page 2)

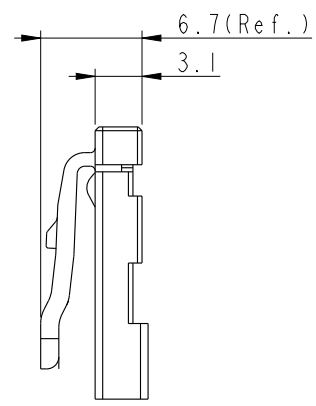
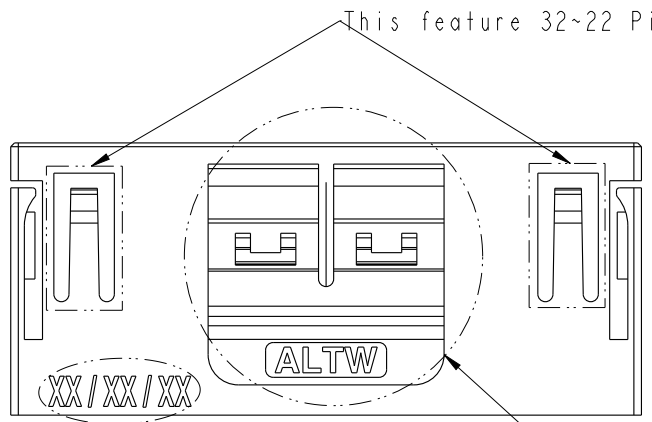
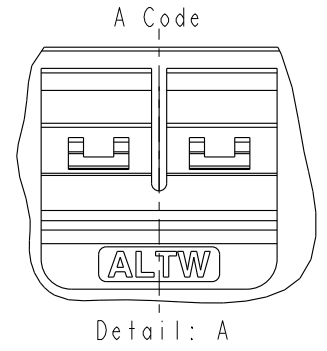
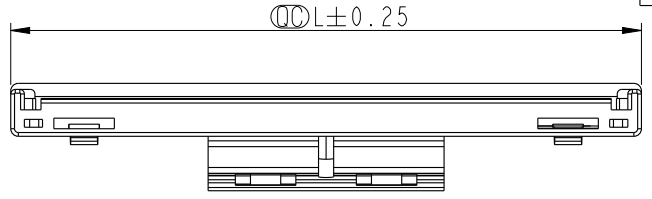

Z A - XX N M A N - B N 001

- Z-ZCONNECT Non Shielded
- A-A Coded
- XX-Number of Contacts
- N-None Pitch
- M-Male PLUG
- 001-Series Number
- N-None
- B-Black
- N-None
- A-Assembly

Note:

- * \varnothing Important Dimensions To Check.
- * Material: Thermoplastic, Black.
- * All Parts Are RoHS Compliant.

UNIT: mm

TOLERANCE	
.X	±0.25
.XX	±0.1
.XXX	±0.05
ANGLES	±1°

TITLE Z CONN., N SHLD, A, M			
SCALE 1:1	SIZE A4	SHEET 1 OF 10	
REV. A	WC-REV. .0	\varnothing : Inspection item	

Amphenol LTW
安費諾亮泰企業股份有限公司

ITEM NO. ZA-XXNMAN-BN001	DRAWN BY Xiaofeng	DATE 2021/01/11
DWG NO. ZA-XXNMAN-BN001	CHECKED BY Feng-Li	DATE 2021/01/11
CUSTOMER ALTW	APPROVED BY Jerry	DATE 2021/01/11

THIS DOCUMENT IS SUBJECT TO CHANGE WITHOUT NOTICE. IT IS CONFIDENTIAL AND A PROPERTY OF Amphenol LTW. DISCLOSURE TO THIRD PARTY HAS TO BE AUTHORIZED BY Amphenol LTW.

Flexible Printed Circuit
Pitch 0.9mm

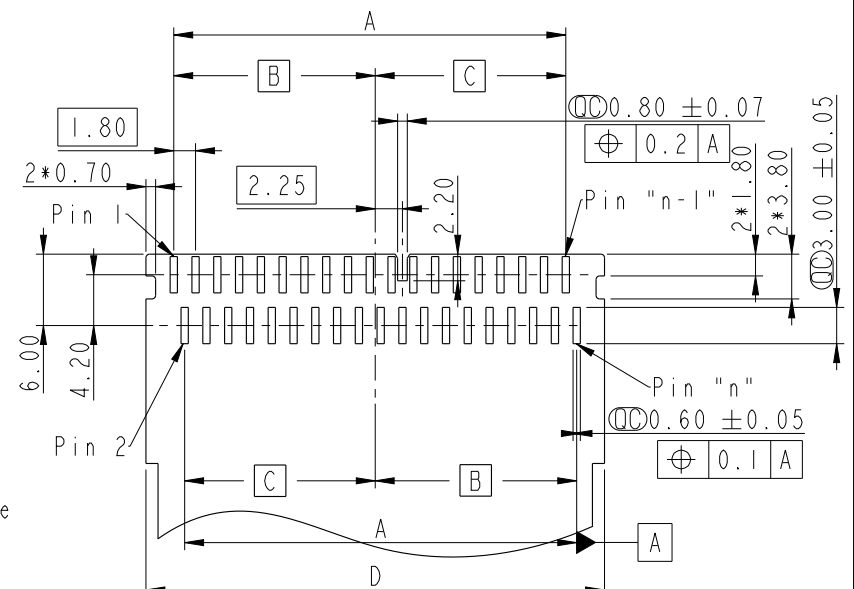
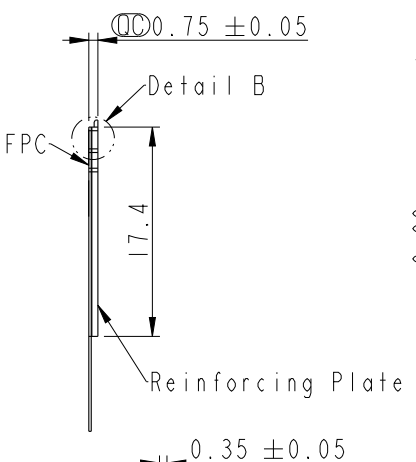
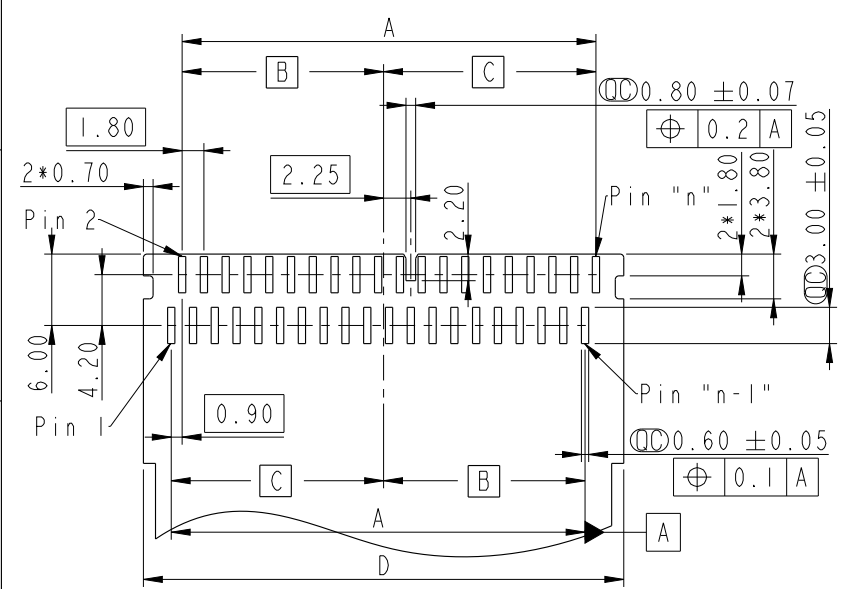

RECOMMENDED FPC LAYOUT

RECOMMENDED FPC LAYOUT

FPC CONNECTOR SIZE

PIN	L (mm)	A (mm)	B (mm)	C (mm)	D (mm)
24	27.3	19.8	9.45	10.35	25.3
28	30.9	23.4	11.25	12.15	28.9
32	34.5	27.0	13.05	13.95	32.5
36	38.1	30.6	14.85	15.75	36.1
40	41.7	34.2	16.65	17.55	39.7

FPC CONNECTOR SIZE

PIN	L (mm)	A (mm)	B (mm)	C (mm)	D (mm)
22	25.5	18.0	9.45	8.55	23.5
26	29.1	21.6	11.25	10.35	27.1
30	32.7	25.2	13.05	12.15	30.7
34	36.3	28.8	14.85	13.95	34.3
38	39.9	32.4	16.65	16.65	37.9

UNIT: mm

TOLERANCE	
.X	±0.25
.XX	±0.1
.XXX	±0.05
ANGLES	±1°

TITLE Z CONN., N SHLD, A, M			
SCALE 1:1	SIZE A4	SHEET 2 OF 10	
REV.	WC-REV.	.0	QC: Inspection item

Amphenol LTW
安費諾亮泰企業股份有限公司

ITEM NO ZA-XXNMAN-BN0001	DRAWN BY Xiaofeng	DATE 2021/01/11
DWG NO ZA-XXNMAN-BN0001	CHECKED BY Feng-Li	DATE 2021/01/11
CUSTOMER ALTW	APPROVED BY Jerry	DATE 2021/01/11

Flexible Printed Circuit
Pitch 1.8mm

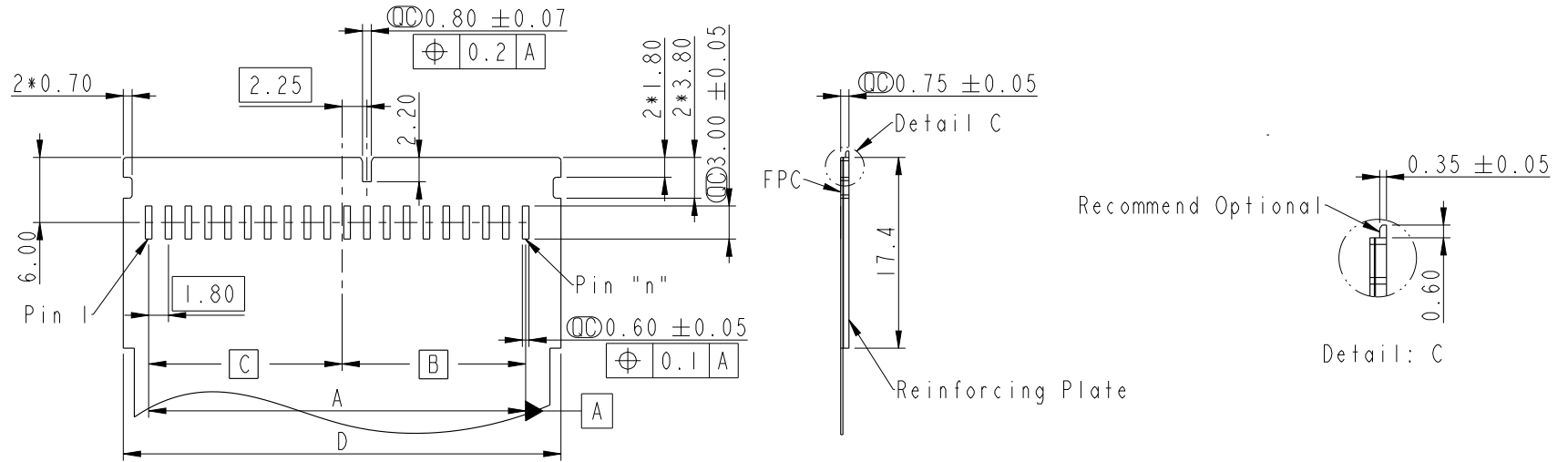

RECOMMENDED FPC LAYOUT

FPC CONNECTOR SIZE

PIN	A (mm)	B (mm)	C (mm)	D (mm)
11	18.0	9.45	8.55	23.5
12	19.8	9.45	10.35	25.3
13	21.6	11.25	10.35	27.1
14	23.4	11.25	12.15	28.9
15	25.2	13.05	12.15	30.7
16	27.0	13.05	13.95	32.5
17	28.8	14.85	13.95	34.3
18	30.6	14.85	15.75	36.1
19	32.4	16.65	15.75	39.7
20	34.2	16.65	17.55	39.7

UNIT: mm

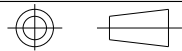

TITLE Z CONN., N SHLD, A, M			
SCALE 1:1	SIZE A4	SHEET 3 OF 10	
REV. 01	WC-REV. .0	Ⓞ: Inspection item	

Amphenol LTW
安費諾亮泰企業股份有限公司

ITEM NO ZA-XXNMAN-BN0001	DRAWN BY Xiaofeng	DATE 2021/01/14
DWG NO ZA-XXNMAN-BN0001	CHECKED BY Feng-Li	DATE 2021/01/14
CUSTOMER ALTW	APPROVED BY Jerry	DATE 2021/01/14

THIS DOCUMENT IS SUBJECT TO CHANGE WITHOUT NOTICE. IT IS CONFIDENTIAL AND A PROPERTY OF AMPHENOL LTW. DISCLOSURE TO THIRD PARTY HAS TO BE AUTHORIZED BY AMPHENOL LTW.

THIS DOCUMENT IS SUBJECT TO CHANGE WITHOUT NOTICE. IT IS CONFIDENTIAL AND A PROPERTY OF AMPHENOL LTW. DISCLOSURE TO THIRD PARTY HAS TO BE AUTHORIZED BY AMPHENOL LTW.

Flexible Printed Circuit
Pitch 2.7mm

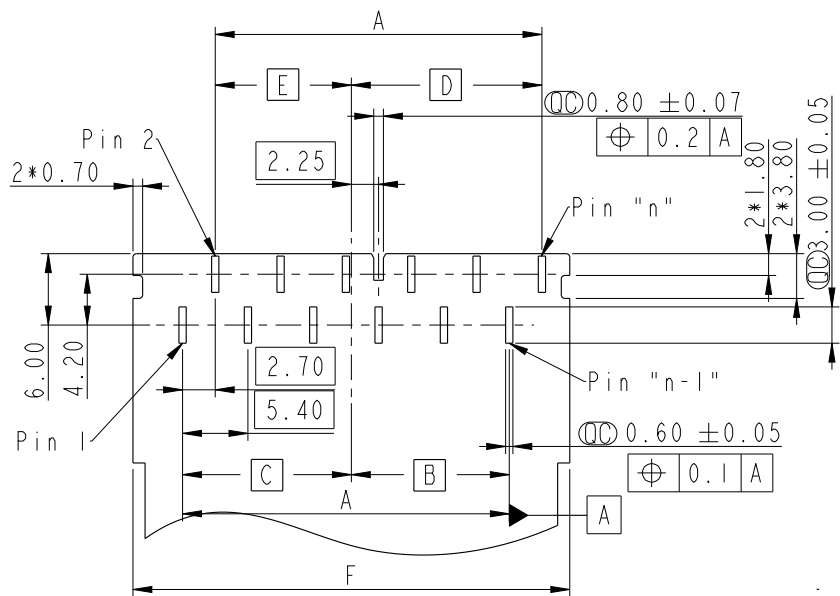

RECOMMENDED FPC LAYOUT

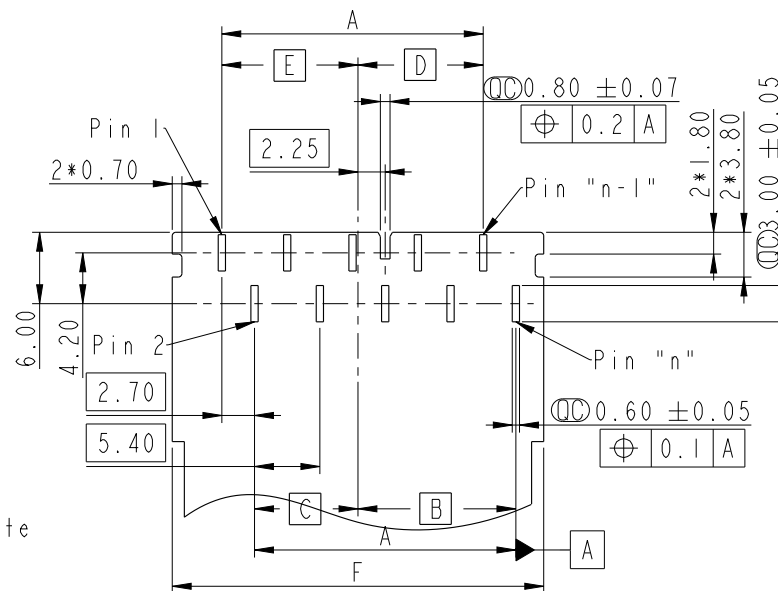

RECOMMENDED FPC LAYOUT

FPC CONNECTOR SIZE

PIN	F (mm)	A (mm)	B (mm)	C (mm)	D (mm)	E (mm)
8	25.3	16.2	7.65	8.55	10.35	5.85
12	36.1	27.0	13.05	13.95	15.75	11.25

FPC CONNECTOR SIZE

PIN	F (mm)	A (mm)	B (mm)	C (mm)	D (mm)	E (mm)
10	30.7	21.6	13.05	8.55	10.35	11.25

UNIT: mm

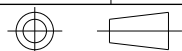

TITLE Z CONN., N SHLD, A, M			
SCALE 1:1	SIZE A4	SHEET 4 OF 10	
REV. A	WC-REV. .0	QC: Inspection item	

Amphenol LTW
安費諾亮泰企業股份有限公司

ITEM NO ZA-XXNMAN-BN0001	DRAWN BY Xiaofeng	DATE 2021/01/14
DWG NO ZA-XXNMAN-BN0001	CHECKED BY Feng-Li	DATE 2021/01/14
CUSTOMER ALTW	APPROVED BY Jerry	DATE 2021/01/14

THIS DOCUMENT IS SUBJECT TO CHANGE WITHOUT NOTICE. IT IS CONFIDENTIAL AND A PROPERTY OF Amphenol LTW. DISCLOSURE TO THIRD PARTY HAS TO BE AUTHORIZED BY Amphenol LTW.

Flexible Flat Cables
Pitch 0.9mm

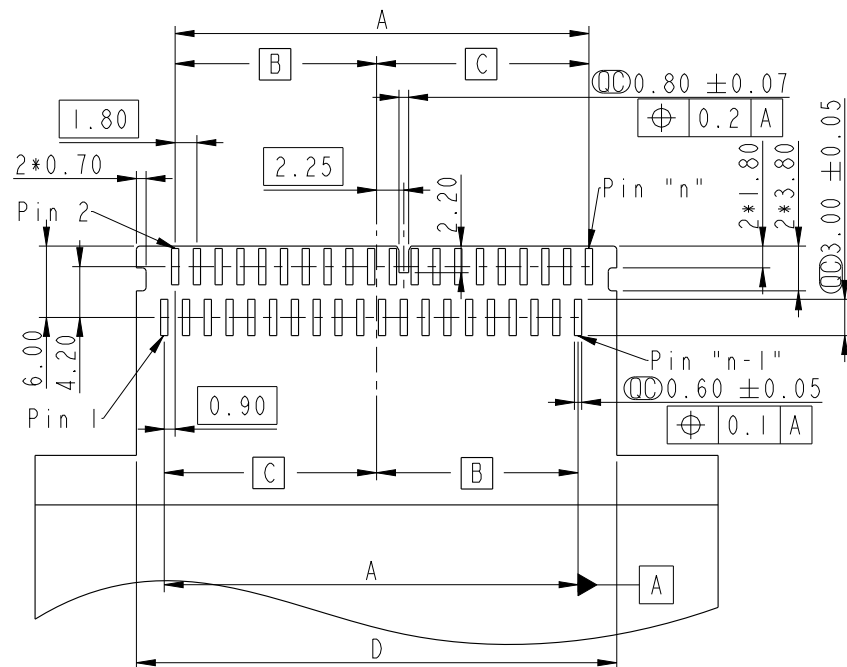

RECOMMENDED FFC LAYOUT

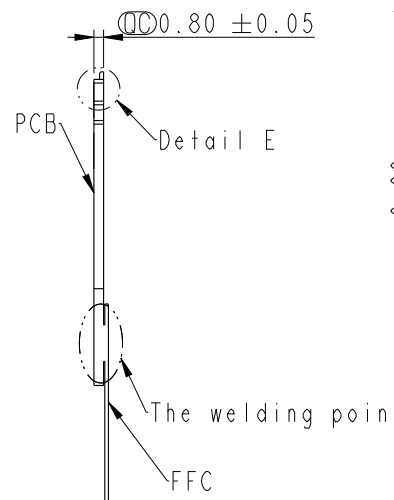

Detail: E

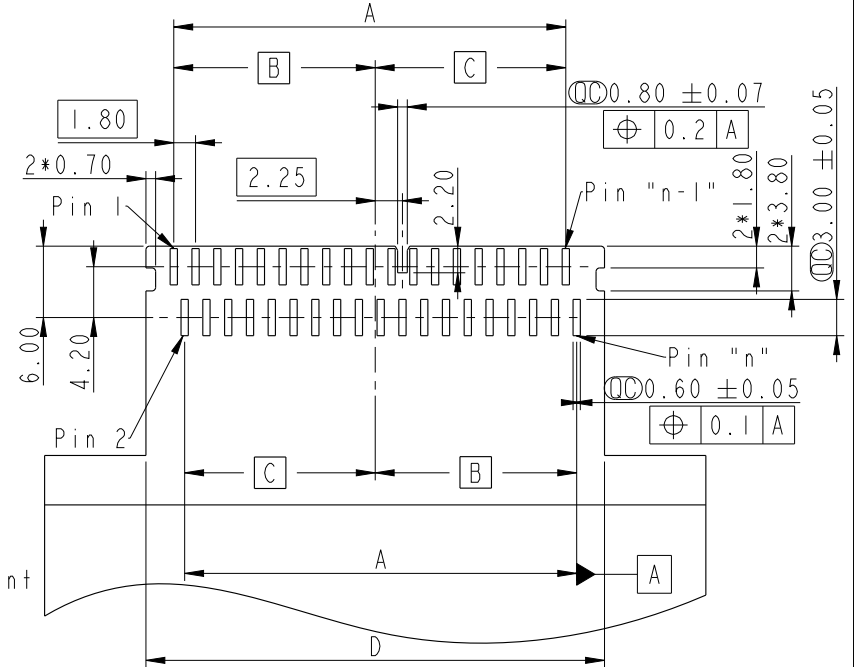

RECOMMENDED FFC LAYOUT

FFC CONNECTOR SIZE					
PIN	L (mm)	A (mm)	B (mm)	C (mm)	D (mm)
24	27.3	19.8	9.45	10.35	25.3
28	30.9	23.4	11.25	12.15	28.9
32	34.5	27.0	13.05	13.95	32.5
36	38.1	30.6	14.85	15.75	36.1
40	41.7	34.2	16.65	17.55	39.7

FFC CONNECTOR SIZE					
PIN	L (mm)	A (mm)	B (mm)	C (mm)	D (mm)
22	25.5	18.0	9.45	8.55	23.5
26	29.1	21.6	11.25	10.35	27.1
30	32.7	25.2	13.05	12.15	30.7
34	36.3	28.8	14.85	13.95	34.3
38	39.9	32.4	16.65	16.65	37.9

UNIT: mm

TITLE: Z CONN., N SHLD, A, M

TOLERANCE
.X ±0.25
.XX ±0.1
.XXX ±0.05
ANGLES ±1°

SCALE: 1:1 SIZE: A4 SHEET: 5 OF 10

REV. A WC-REV. .0 Inspection item

Amphenol LTW
安費諾亮泰企業股份有限公司

ITEM NO: ZA-XXNMAN-BN0001 DRAWN BY: Xiaofeng DATE: 2021/01/15

DWG NO: ZA-XXNMAN-BN0001 CHECKED BY: Feng-Li DATE: 2021/01/15

CUSTOMER: ALTW APPROVED BY: Jerry DATE: 2021/01/15

Flexible Flat Cables
Pitch 1.8mm

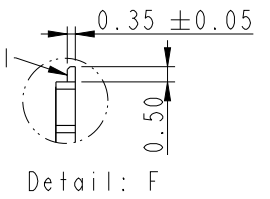
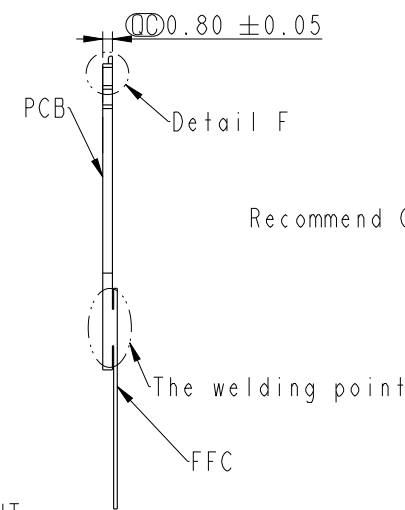
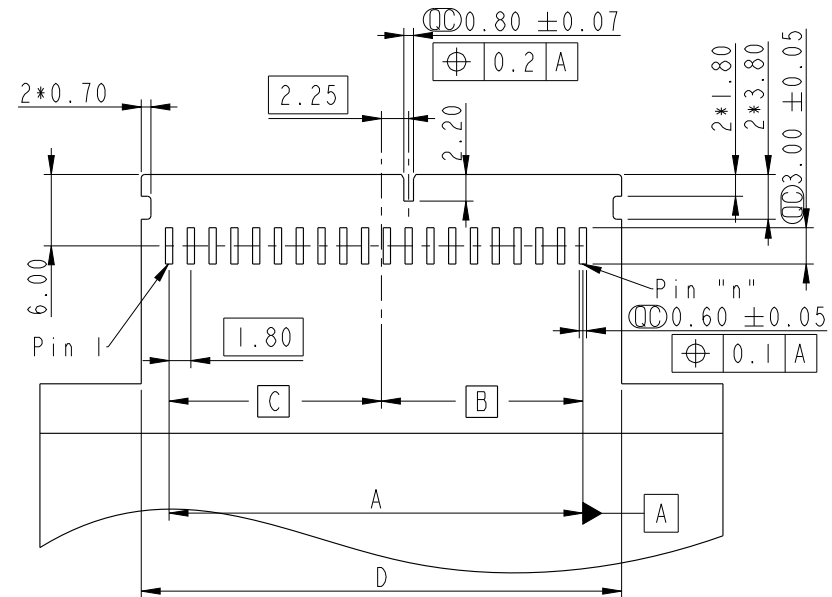

RECOMMENDED FFC LAYOUT

FFC CONNECTOR SIZE				
PIN	A (mm)	B (mm)	C (mm)	D (mm)
11	18.0	9.45	8.55	23.5
12	19.8	9.45	10.35	25.3
13	21.6	11.25	10.35	27.1
14	23.4	11.25	12.15	28.9
15	25.2	13.05	12.15	30.7
16	27.0	13.05	13.95	32.5
17	28.8	14.85	13.95	34.3
18	30.6	14.85	15.75	36.1
19	32.4	16.65	15.75	39.7
20	34.2	16.65	17.55	39.7

UNIT: mm

TOLERANCE
.X ±0.25
.XX ±0.1
.XXX ±0.05
ANGLES ±1°

TITLE
Z CONN., N SHLD, A, M

SCALE 1:1 SIZE A4 SHEET 6 OF 10

REV. A WC-REV. .0

QC: Inspection item

Amphenol LTW
安費諾亮泰企業股份有限公司

ITEM NO
ZA-XXNMAN-BN0001

DWG NO
ZA-XXNMAN-BN0001

CUSTOMER
ALTW

DRAWN BY
Xiaofeng

CHECKED BY
Feng-Li

APPROVED BY
Jerry

DATE
2021/01/15

DATE
2021/01/15

DATE
2021/01/15

THIS DOCUMENT IS SUBJECT TO CHANGE WITHOUT NOTICE. IT IS CONFIDENTIAL AND A PROPERTY OF AMPHENOL LTW. DISCLOSURE TO THIRD PARTY HAS TO BE AUTHORIZED BY AMPHENOL LTW.

THIS DOCUMENT IS SUBJECT TO CHANGE WITHOUT NOTICE. IT IS CONFIDENTIAL AND A PROPERTY OF Amphenol LTW. DISCLOSURE TO THIRD PARTY HAS TO BE AUTHORIZED BY Amphenol LTW.

Flexible Flat Cables
Pitch 2.7mm

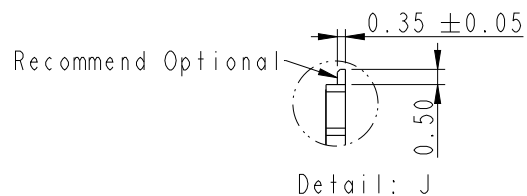
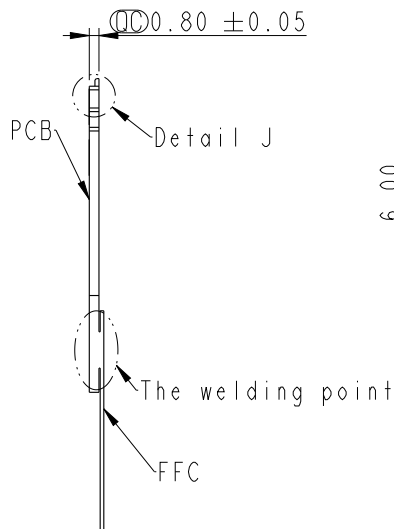
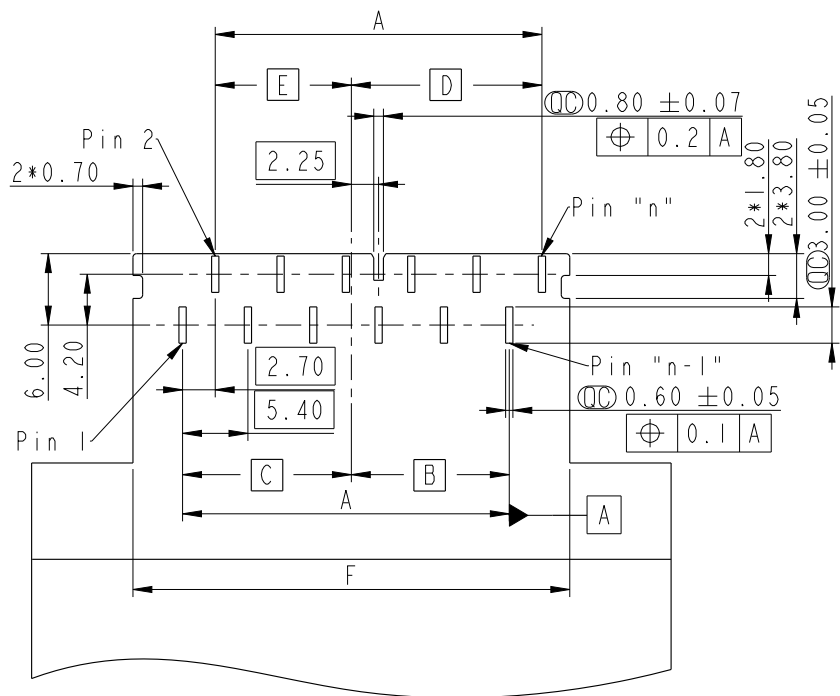

RECOMMENDED FFC LAYOUT

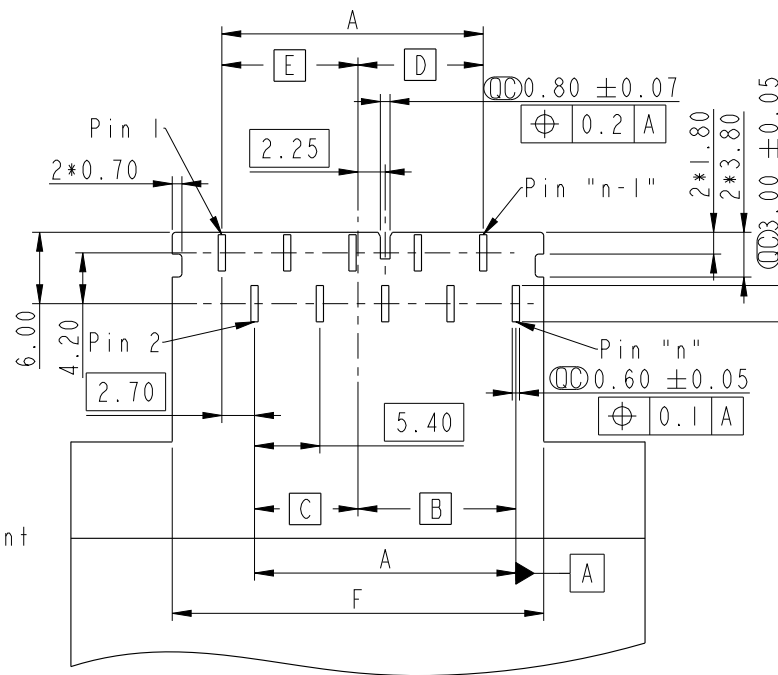

RECOMMENDED FFC LAYOUT

FFC CONNECTOR SIZE

PIN	F (mm)	A (mm)	B (mm)	C (mm)	D (mm)	E (mm)
8	25.3	16.2	7.65	8.55	10.35	5.85
12	36.1	27.0	13.05	13.95	15.75	11.25

FFC CONNECTOR SIZE

PIN	F (mm)	A (mm)	B (mm)	C (mm)	D (mm)	E (mm)
10	30.7	21.6	13.05	8.55	10.35	11.25

UNIT: mm

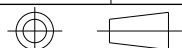

TITLE Z CONN., N SHLD, A, M			
SCALE 1:1	SIZE A4	SHEET 7 OF 10	
REV. A	WC-REV. .0	QC: Inspection item	

Amphenol LTW
安費諾亮泰企業股份有限公司

ITEM NO ZA-XXNMAN-BN0001	DRAWN BY Xiaofeng	DATE 2021/01/15
DWG NO ZA-XXNMAN-BN0001	CHECKED BY Feng-Li	DATE 2021/01/15
CUSTOMER ALTW	APPROVED BY Jerry	DATE 2021/01/15

THIS DOCUMENT IS SUBJECT TO CHANGE WITHOUT NOTICE. IT IS CONFIDENTIAL AND A PROPERTY OF Amphenol LTW. DISCLOSURE TO THIRD PARTY HAS TO BE AUTHORIZED BY Amphenol LTW.

Wire to Board
Pitch 0.9mm

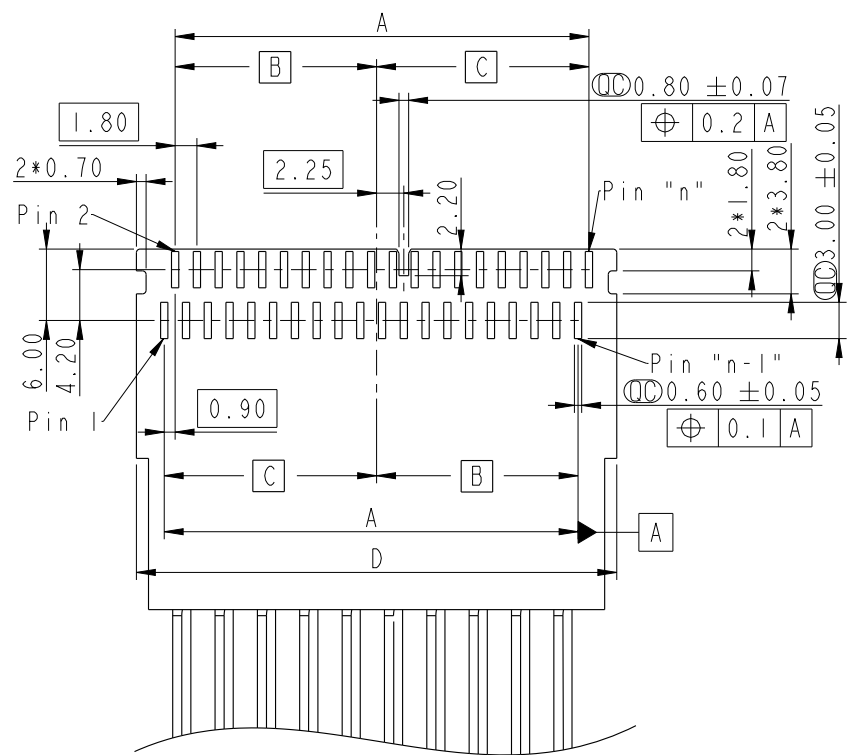

RECOMMENDED WTB LAYOUT

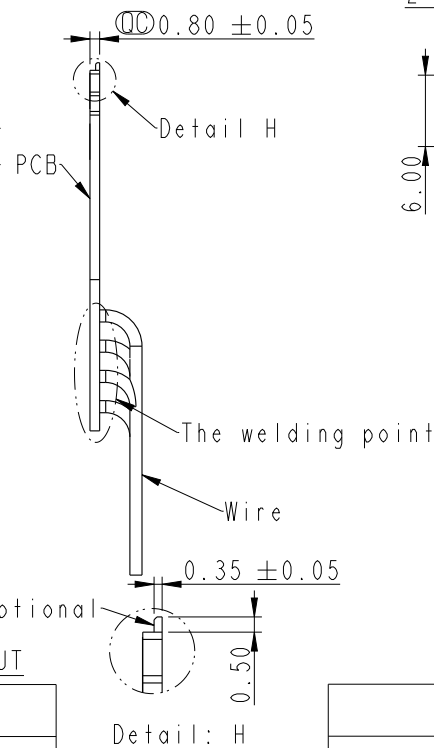

Detail: H

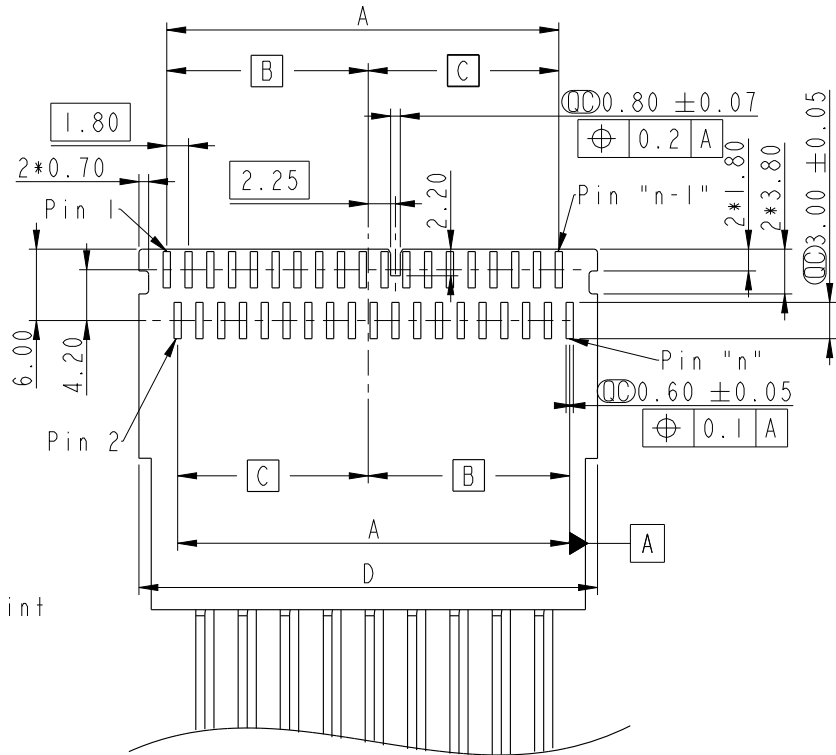

RECOMMENDED WTB LAYOUT

WTB CONNECTOR SIZE

PIN	L (mm)	A (mm)	B (mm)	C (mm)	D (mm)
24	27.3	19.8	9.45	10.35	25.3
28	30.9	23.4	11.25	12.15	28.9
32	34.5	27.0	13.05	13.95	32.5
36	38.1	30.6	14.85	15.75	36.1
40	41.7	34.2	16.65	17.55	39.7

WTB CONNECTOR SIZE

PIN	L (mm)	A (mm)	B (mm)	C (mm)	D (mm)
22	25.5	18.0	9.45	8.55	23.5
26	29.1	21.6	11.25	10.35	27.1
30	32.7	25.2	13.05	12.15	30.7
34	36.3	28.8	14.85	13.95	34.3
38	39.9	32.4	16.65	16.65	37.9

UNIT: mm

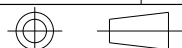

TITLE Z CONN., N SHLD, A, M			
SCALE 1:1	SIZE A4	SHEET 8 OF 10	
REV. A	WC-REV. .0	QC: Inspection item	

Amphenol LTW
安費諾亮泰企業股份有限公司

ITEM NO ZA-XXNMAN-BN0001	DRAWN BY Xiaofeng	DATE 2021/01/15
DWG NO ZA-XXNMAN-BN0001	CHECKED BY Feng-Li	DATE 2021/01/15
CUSTOMER ALTW	APPROVED BY Jerry	DATE 2021/01/15

THIS DOCUMENT IS SUBJECT TO CHANGE WITHOUT NOTICE. IT IS CONFIDENTIAL AND A PROPERTY OF Amphenol LTW. DISCLOSURE TO THIRD PARTY HAS TO BE AUTHORIZED BY Amphenol LTW.

Wire to Board
Pitch 1.8mm

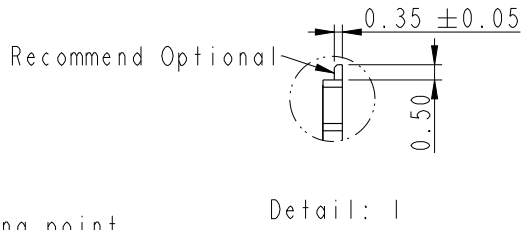
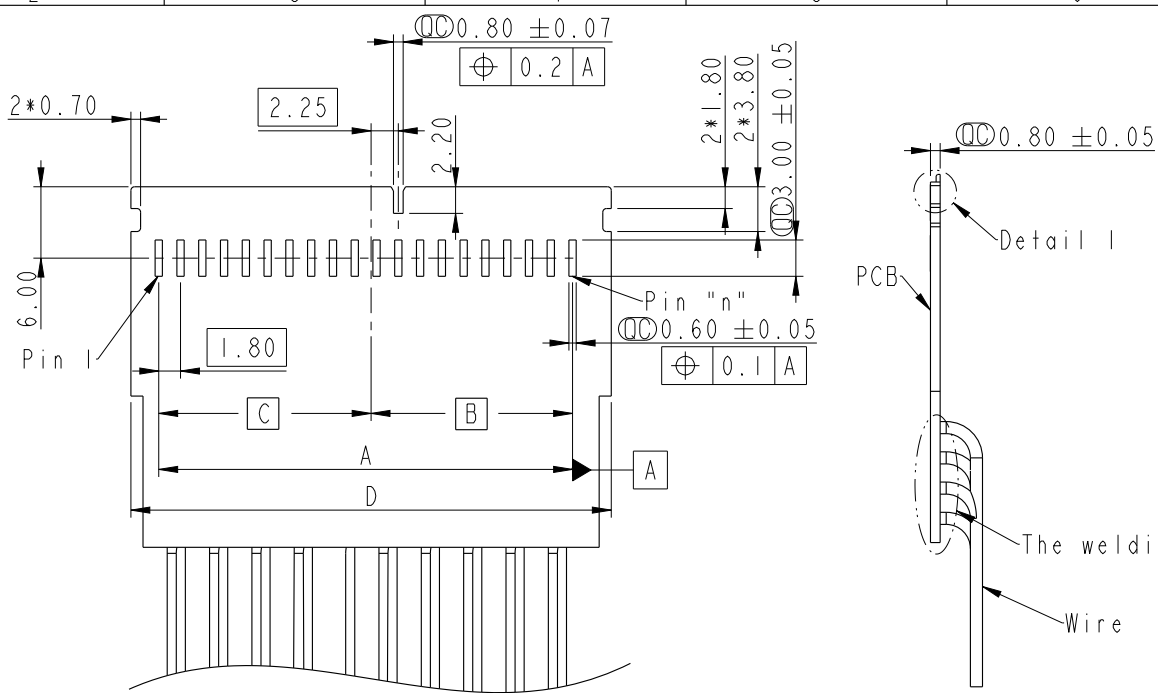

RECOMMENDED WTB LAYOUT

WTB CONNECTOR SIZE				
PIN	A (mm)	B (mm)	C (mm)	D (mm)
11	18.0	9.45	8.55	23.5
12	19.8	9.45	10.35	25.3
13	21.6	11.25	10.35	27.1
14	23.4	11.25	12.15	28.9
15	25.2	13.05	12.15	30.7
16	27.0	13.05	13.95	32.5
17	28.8	14.85	13.95	34.3
18	30.6	14.85	15.75	36.1
19	32.4	16.65	15.75	39.7
20	34.2	16.65	17.55	39.7

UNIT: mm		
TOLERANCE	.X ±0.25	
.XX	±0.1	
.XXX	±0.05	
ANGLES	±1°	

TITLE Z CONN., N SHLD, A, M		
SCALE 1:1	SIZE A4	SHEET 9 OF 10
REV. A	WC-REV. .0	

Amphenol LTW
安費諾亮泰企業股份有限公司

ITEM NO ZA-XXNMAN-BN0001	DRAWN BY Xiaofeng	DATE 2021/01/15
DWG NO ZA-XXNMAN-BN0001	CHECKED BY Feng-Li	DATE 2021/01/15
CUSTOMER ALTW	APPROVED BY Jerry	DATE 2021/01/15

THIS DOCUMENT IS SUBJECT TO CHANGE WITHOUT NOTICE. IT IS CONFIDENTIAL AND A PROPERTY OF Amphenol LTW. DISCLOSURE TO THIRD PARTY HAS TO BE AUTHORIZED BY Amphenol LTW.

Wire to Board
Pitch 2.7mm

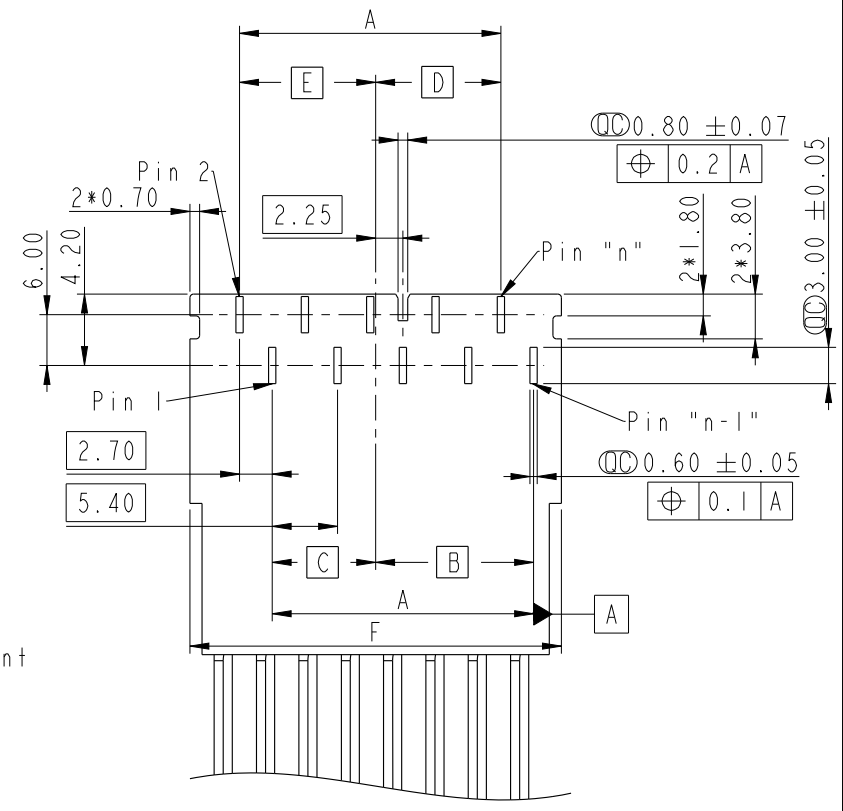
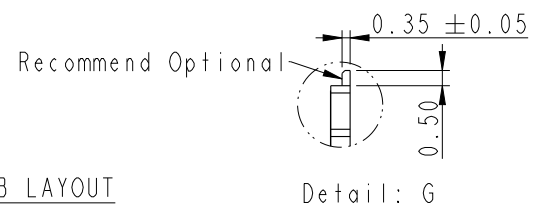
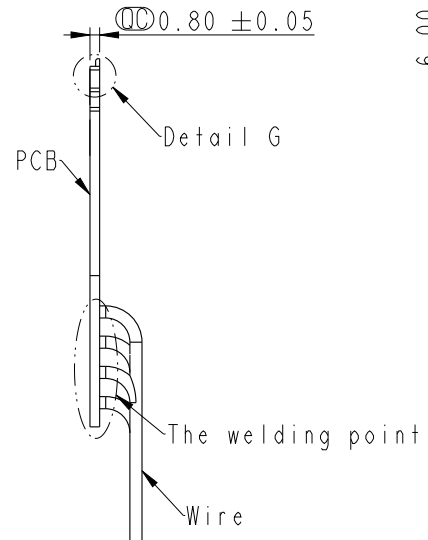
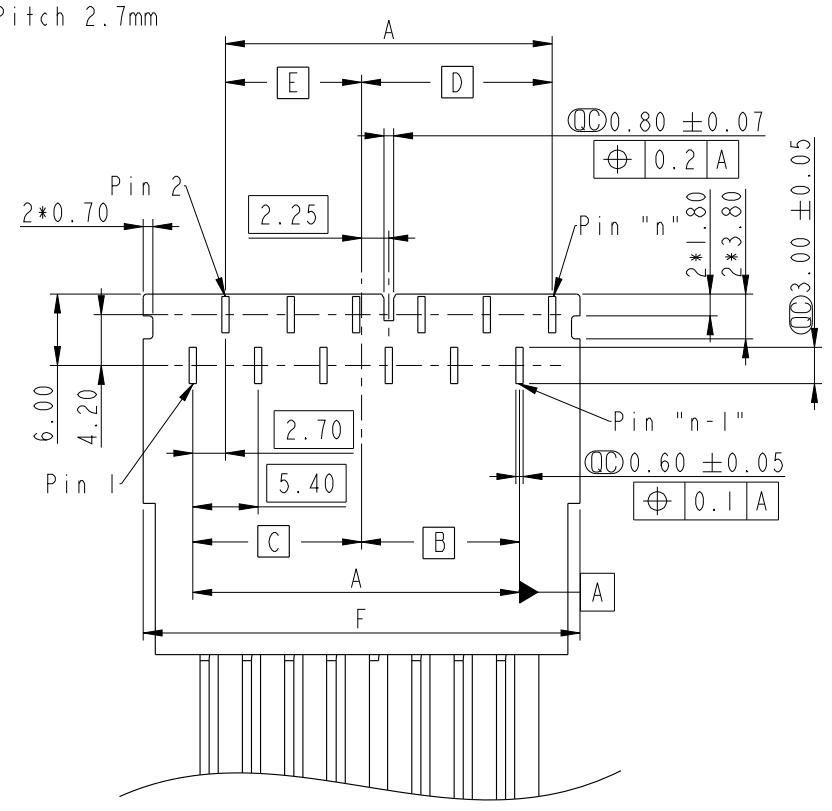

RECOMMENDED WTB LAYOUT

RECOMMENDED WTB LAYOUT

WTB CONNECTOR SIZE

PIN	F (mm)	A (mm)	B (mm)	C (mm)	D (mm)	E (mm)
8	25.3	16.2	7.65	8.55	10.35	5.85
12	36.1	27.0	13.05	13.95	15.75	11.25

WTB CONNECTOR SIZE

PIN	F (mm)	A (mm)	B (mm)	C (mm)	D (mm)	E (mm)
10	30.7	21.6	13.05	8.55	10.35	11.25

UNIT: mm		TITLE Z CONN., N SHLD, A, M
TOLERANCE .X ±0.25 .XX ±0.1 .XXX ±0.05 ANGLES ±1°	SCALE 1:1	SIZE A4
	REV. A	SHEET 10 OF 10
	WC-REV. .0	QC: Inspection item

Amphenol LTW
安費諾亮泰企業股份有限公司

ITEM NO ZA-XXNMAN-BN0001	DRAWN BY Xiaofeng	DATE 2021/01/15
DWG NO ZA-XXNMAN-BN0001	CHECKED BY Feng Li	DATE 2021/01/15
CUSTOMER ALTW	APPROVED BY Jerry	DATE 2021/01/15