



CRYSTAL-TO-LVDS PCI EXPRESS™ CLOCK SYNTHESIZER W/SPREAD SPECTRUM

ICS844204-245

GENERAL DESCRIPTION



The ICS844204-245 is a 4 output PCI Express clock synthesizer optimized to generate low jitter PCIe reference clocks with or without spread spectrum modulation and is a member of the HiPerClockS™ family of high performance clock solutions from IDT. Spread type and amount can be configured via the SSC control pins. Using a 25MHz, 18pF parallel resonant crystal, the device will generate LVDS clocks at either 25MHz, 100MHz, 125MHz or 250MHz. The ICS844204-245 uses a low jitter VCO that easily meets PCI Express jitter requirements and is packaged in a 32-pin VFQFN package.

FEATURES

- Four LVDS outputs at 25MHz, 100MHz, 125MHz or 250MHz
- Crystal oscillator interface, 25MHz, 18pF parallel resonant crystal
- Supports the following output frequencies: 25MHz, 100MHz, 125MHz or 250MHz
- VCO range: 240MHz - 700MHz
- Supports SSC downspread at 0.50% and -0.75%, centerspread at ±0.25% and no spread options
- Cycle-to-cycle jitter: 70ps (typical)
- Period jitter: 40ps (typical)
- Full 3.3V power supply mode
- 0°C to 70°C ambient operating temperature
- Available in both standard (RoHS 5) and lead-free (RoHS 6) packages

BLOCK DIAGRAM

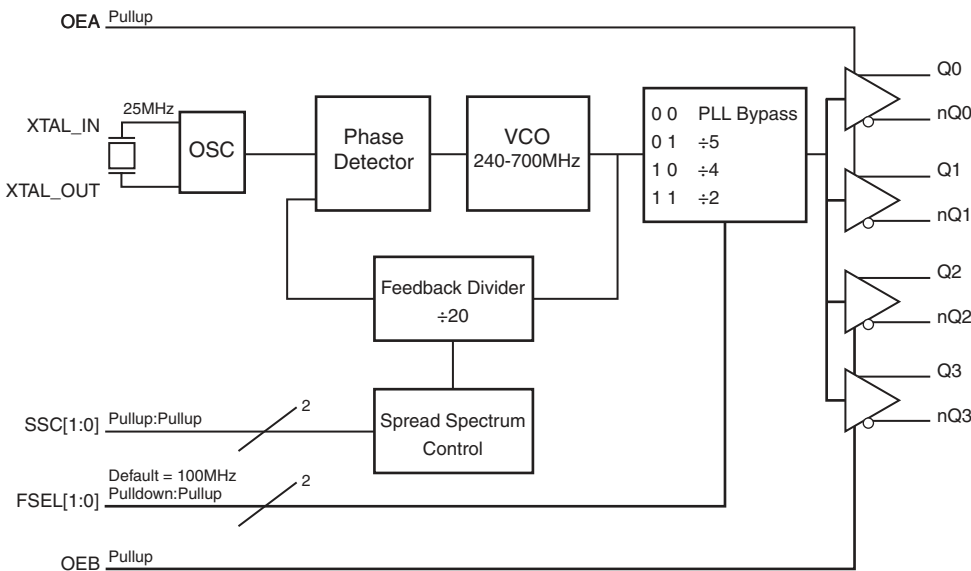

PIN ASSIGNMENT

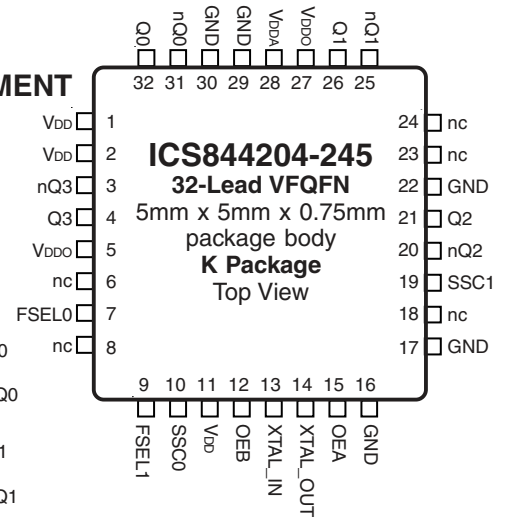

The Preliminary Information presented herein represents a product in pre-production. The noted characteristics are based on initial product characterization and/or qualification. Integrated Device Technology, Incorporated (IDT) reserves the right to change any circuitry or specifications without notice.

TABLE 1. PIN DESCRIPTIONS

Number	Name	Type		Description
1, 2, 11	V _{DD}	Power		Core supply pins.
3, 4	nQ3, Q3	Output		Differential output pair. LVDS interface levels.
5, 27	V _{DDO}	Power		Output supply pins.
6, 8, 18, 23, 24	nc	Unused		No connect.
7	FSEL0	Input	Pullup	Output frequency select pin. See Table 3A. LVCMOS/LVTTL interface levels.
9	FSEL1	Input	Pulldown	Output frequency select pin. See Table 3A. LVCMOS/LVTTL interface levels.
10, 19	SSC0 SSC1	Input	Pullup	Spread spectrum control pins. See Table 3B. LVCMOS/LVTTL interface levels.
12, 15	OEB, OEA	Input		Output enable pins. Logic High, outputs are enabled. Logic LOW, outputs are in Hi-Z. LVCMOS/LVTTL interface levels.
13, 14	XTAL_IN, XTAL_OUT	Input	Pullup	Parallel resonant crystal interface. XTAL_OUT is the output, XTAL_IN is the input. (PLL reference.)
16, 17, 22, 29, 30	GND	Power		Power supply ground.
20, 21	nQ2, Q2	Output		Differential output pair. LVDS interface levels.
25, 26	nQ1, Q1	Output		Differential output pair. LVDS interface levels.
28	V _{DDA}	Power		Analog supply pin.
31, 32	nQ0, Q0	Output		Differential output pair. LVDS interface levels.

NOTE: *Pullup and Pulldown* refer to internal input resistors. See Table 2, Pin Characteristics, for typical values.

TABLE 2. PIN CHARACTERISTICS

Symbol	Parameter	Test Conditions	Minimum	Typical	Maximum	Units
C _{IN}	Input Capacitance			4		pF
R _{PULLUP}	Input Pullup Resistor			51		kΩ
R _{PULLDOWN}	Input Pulldown Resistor			51		kΩ

TABLE 3A. FSEL[1:0] FUNCTION TABLE

Input		Outputs
FSEL1	FSEL0	Q0:3/nQ0:3
0	0	PLL Bypass (25MHz)
0	1	100MHz (default)
1	0	125MHz
1	1	250MHz

TABLE 3B. SSC[1:0] FUNCTION TABLE

Input		Spread %
SSC1	SSC0	
0	0	Center ± -0.25
0	1	Down -0.5
1	0	Down -0.75
1	1	No Spread (default)

ABSOLUTE MAXIMUM RATINGS

Supply Voltage, V_{DD}	4.6V
Inputs, V_I	-0.5V to $V_{DD} + 0.5V$
Outputs, I_O	
Continuous Current	10mA
Surge Current	15mA
Package Thermal Impedance, θ_{JA}	42.4°C/W (0 mps)
Storage Temperature, T_{STG}	-65°C to 150°C

NOTE: Stresses beyond those listed under Absolute Maximum Ratings may cause permanent damage to the device. These ratings are stress specifications only. Functional operation of product at these conditions or any conditions beyond those listed in the *DC Characteristics* or *AC Characteristics* is not implied. Exposure to absolute maximum rating conditions for extended periods may affect product reliability.

TABLE 4A. POWER SUPPLY DC CHARACTERISTICS, $V_{DD} = V_{DDA} = V_{DDO} = 3.3V \pm 5\%$, $T_A = 0^\circ C$ TO $70^\circ C$

Symbol	Parameter	Test Conditions	Minimum	Typical	Maximum	Units
V_{DD}	Core Supply Voltage		3.135	3.3	3.465	V
V_{DDA}	Analog Supply Voltage		$V_{DD} - 0.12$	3.3	V_{DD}	V
V_{DDO}	Output Supply Voltage		3.135	3.3	3.465	V
I_{DD}	Power Supply Current			89		mA
I_{DDA}	Analog Supply Current			12		mA
I_{DDO}	Output Supply Current			54		mA

TABLE 4B. LVCMOS / LVTTTL DC CHARACTERISTICS, $V_{DD} = V_{DDA} = V_{DDO} = 3.3V \pm 5\%$, $T_A = 0^\circ C$ TO $70^\circ C$

Symbol	Parameter	Test Conditions	Minimum	Typical	Maximum	Units
V_{IH}	Input High Voltage		2		$V_{DD} + 0.3$	V
V_{IL}	Input Low Voltage		-0.3		0.8	V
I_{IH}	Input High Current	FSEL1	$V_{DD} = V_{IN} = 3.465V$		150	μA
		SSC0, SSC1, FSEL0, OEA, OEB	$V_{DD} = V_{IN} = 3.465V$		5	μA
I_{IL}	Input Low Current	FSEL1	$V_{DD} = 3.465V, V_{IN} = 0V$	-5		μA
		SSC0, SSC1, FSEL0, OEA, OEB	$V_{DD} = 3.465V, V_{IN} = 0V$	-150		μA

TABLE 4C. LVDS DC CHARACTERISTICS, $V_{DD} = V_{DDA} = V_{DDO} = 3.3V \pm 5\%$, $T_A = 0^\circ C$ TO $70^\circ C$

Symbol	Parameter	Test Conditions	Minimum	Typical	Maximum	Units
V_{OD}	Differential Output Voltage			350		mV
ΔV_{OD}	V_{OD} Magnitude Change			50		mV
V_{OS}	Offset Voltage			1.33		V
ΔV_{OS}	V_{OS} Magnitude Change			50		mV

TABLE 5. CRYSTAL CHARACTERISTICS

Parameter	Test Conditions	Minimum	Typical	Maximum	Units
Mode of Oscillation		Fundamental			
Frequency			25		MHz
Equivalent Series Resistance (ESR)				TBD	Ω
Shunt Capacitance				7	pF
Drive Level				100	μ W

NOTE: Characterized using an 18pF parallel resonant crystal.

TABLE 6. AC CHARACTERISTICS, $V_{DD} = V_{DDA} = V_{DDO} = 3.3V \pm 5\%$, $T_A = 0^\circ\text{C}$ TO 70°C

Symbol	Parameter	Test Conditions	Minimum	Typical	Maximum	Units
f_{OUT}	Output Frequency			25		MHz
				125		MHz
				100		MHz
				250		MHz
$f_{jit(per)}$	Period Jitter, RMS	25MHz		35		ps
		100MHz		45		ps
		125MHz		40		ps
		250MHz		40		ps
$f_{jit(cc)}$	Cycle-to-Cycle Jitter; NOTE 1, 2	25MHz		60		ps
		100MHz		70		ps
		125MHz		60		ps
		250MHz		70		ps
$t_{sk(o)}$	Output Skew; NOTE 2, 3			40		ps
F_{xtal}	Crystal Input Range; NOTE 1		12	25	35	MHz
F_M	SSC Modulation Frequency; NOTE 4			TBD		kHz
F_{MF}	SSC Modulation Factor; NOTE 4			TBD		%
SSC_{red}	Spectral Reduction; NOTE 5			13		dB
t_{STABLE}	Power-up to Stable Clock Output				10	ms
t_R / t_F	Output Rise/Fall Time	20% - 80%		525		ps
odc	Output Duty Cycle			50		%

NOTE 1: This parameter is defined in accordance with JEDEC Standard 65.

NOTE 2: Only valid within the VCO operating range.

NOTE 3: Defined as skew between outputs at the same supply voltage and with equal load conditions. Measured at the output differential cross points.

NOTE 4: Spread Spectrum clocking enabled.

PARAMETER MEASUREMENT INFORMATION

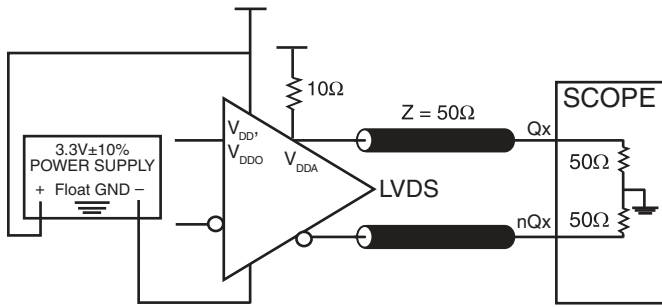

3.3V LVDS OUTPUT LOAD AC TEST CIRCUIT

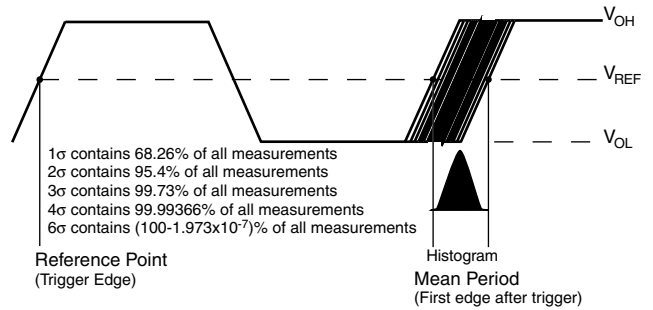

PERIOD JITTER

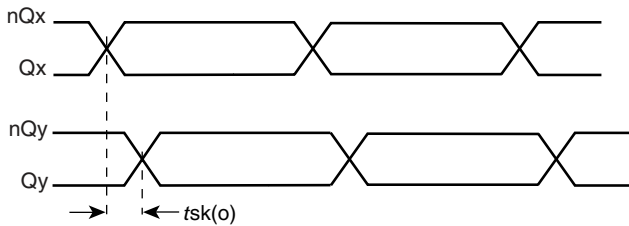

OUTPUT SKEW

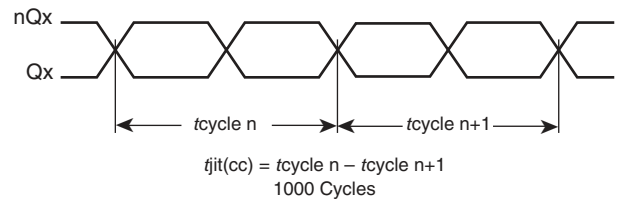

CYCLE-TO-CYCLE JITTER

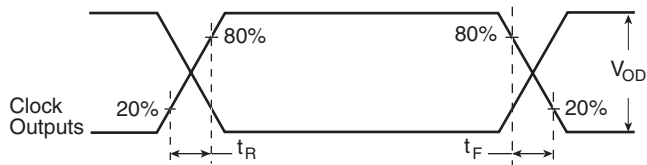

OUTPUT RISE/FALL TIME

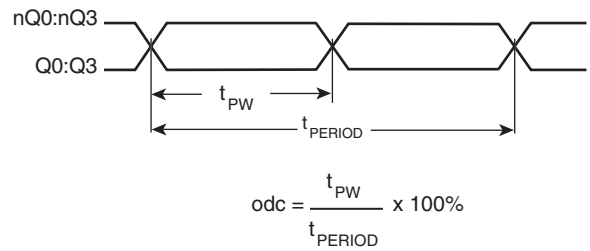

OUTPUT DUTY CYCLE/PULSE WIDTH/PERIOD

APPLICATION INFORMATION

POWER SUPPLY FILTERING TECHNIQUES

As in any high speed analog circuitry, the power supply pins are vulnerable to random noise. The ICS844204-245 provides separate power supplies to isolate any high switching noise from the outputs to the internal PLL. V_{DD} , V_{DDA} and V_{DDO} should be individually connected to the power supply plane through vias, and bypass capacitors should be used for each pin. To achieve optimum jitter performance, power supply isolation is required. *Figure 1* illustrates how a 10Ω resistor along with a $10\mu\text{F}$ and a $.01\mu\text{F}$ bypass capacitor should be connected to each V_{DDA} .

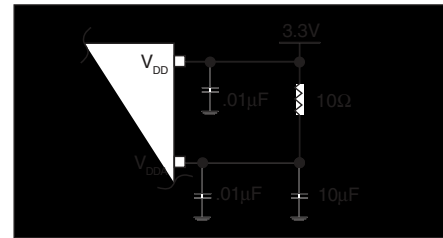

FIGURE 1. POWER SUPPLY FILTERING

CRYSTAL INPUT INTERFACE

The ICS844204-245 has been characterized with 18pF parallel resonant crystals. The capacitor values shown in *Figure 2* below

were determined using a 25MHz, 18pF parallel resonant crystal and were chosen to minimize the ppm error.

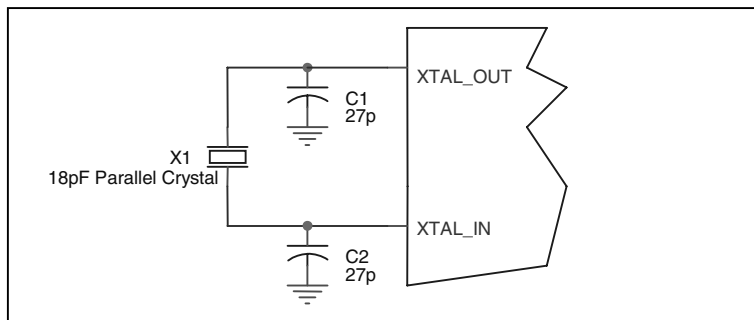

FIGURE 2. CRYSTAL INPUT INTERFACE

RECOMMENDATIONS FOR UNUSED INPUT AND OUTPUT PINS

INPUTS:

CRYSTAL INPUTS

For applications not requiring the use of the crystal oscillator input, both XTAL_IN and XTAL_OUT can be left floating. Though not required, but for additional protection, a $1\text{k}\Omega$ resistor can be tied from XTAL_IN to ground.

LVC MOS CONTROL PINS

All control pins have internal pull-ups or pull-downs; additional resistance is not required but can be added for additional protection. A $1\text{k}\Omega$ resistor can be used.

OUTPUTS:

LVDS OUTPUTS

All unused LVDS output pairs can be either left floating or terminated with 100Ω across. If they are left floating, there should be no trace attached.

LVC MOS TO XTAL INTERFACE

The XTAL_IN input can accept a single-ended LVC MOS signal through an AC couple capacitor. A general interface diagram is shown in *Figure 3*. The XTAL_OUT pin can be left floating. The input edge rate can be as slow as 10ns. For LVC MOS inputs, it is recommended that the amplitude be reduced from full swing to half swing in order to prevent signal interference with the power rail and to reduce noise. This configuration requires that the output impedance of the driver

(R_o) plus the series resistance (R_s) equals the transmission line impedance. In addition, matched termination at the crystal input will attenuate the signal in half. This can be done in one of two ways. First, R_1 and R_2 in parallel should equal the transmission line impedance. For most 50Ω applications, R_1 and R_2 can be 100Ω . This can also be accomplished by removing R_1 and making R_2 50Ω .

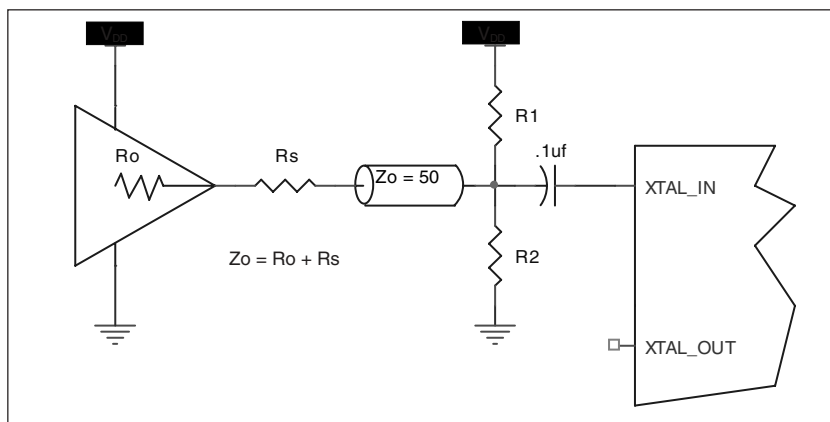

FIGURE 3. GENERAL DIAGRAM FOR LVC MOS DRIVER TO XTAL INPUT INTERFACE

THERMAL RELEASE PATH

The expose metal pad provides heat transfer from the device to the P.C. board. The expose metal pad is ground pad connected to ground plane through thermal via. The exposed pad on the device to the exposed metal pad on the PCB is contacted through

solder as shown in *Figure 4*. For further information, please refer to the Application Note on Surface Mount Assembly of Amkor's Thermally /Electrically Enhance Leadframe Base Package, Amkor Technology.

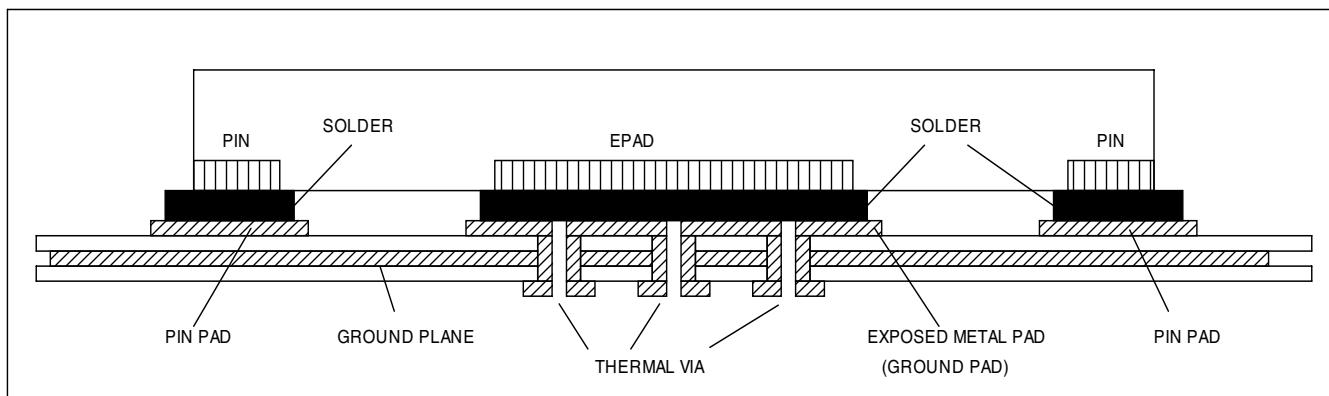

FIGURE 4. P.C. BOARD FOR EXPOSED PAD THERMAL RELEASE PATH EXAMPLE

3.3V LVDS DRIVER TERMINATION

A general LVDS interface is shown in *Figure 5*. In a 100Ω differential transmission line environment, LVDS drivers require a matched load termination of 100Ω across near the receiver

input. For a multiple LVDS outputs buffer, if only partial outputs are used, it is recommended to terminate the un-used outputs.

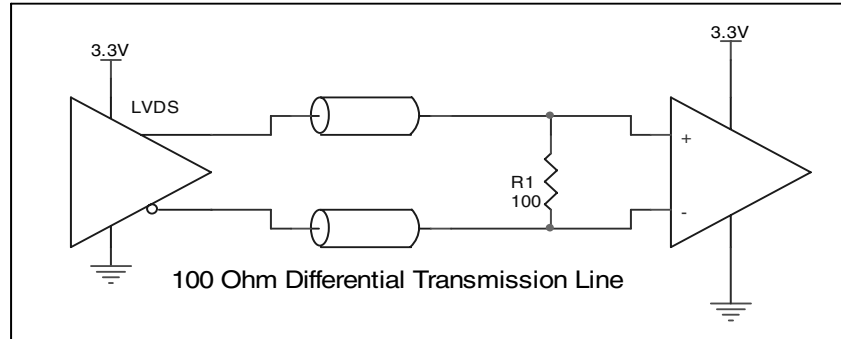

FIGURE 5. TYPICAL LVDS DRIVER TERMINATION

POWER CONSIDERATIONS

This section provides information on power dissipation and junction temperature for the ICS844204-245. Equations and example calculations are also provided.

1. Power Dissipation.

The total power dissipation for the ICS844204-245 is the sum of the core power plus the analog power plus the power dissipated in the load(s). The following is the power dissipation for $V_{DD} = 3.3V + 5\% = 3.645V$, which gives worst case results.

- Power (core)_{MAX} = $V_{DD_MAX} * (I_{DD_MAX} + I_{DDA_MAX} + I_{DDO_MAX}) = 2.465V * (89mA + 12mA + 54mA) = 155mW$

2. Junction Temperature.

Junction temperature, T_j, is the temperature at the junction of the bond wire and bond pad and directly affects the reliability of the device. The maximum recommended junction temperature for HiPerClockS™ devices is 125°C.

The equation for T_j is as follows: $T_j = \theta_{JA} * Pd_total + T_A$

T_j = Junction Temperature

θ_{JA} = Junction-to-Ambient Thermal Resistance

Pd_{total} = Total Device Power Dissipation (example calculation is in section 1 above)

T_A = Ambient Temperature

In order to calculate junction temperature, the appropriate junction-to-ambient thermal resistance θ_{JA} must be used. Assuming no air flow and a multi-layer board, the appropriate value is 42.4°C/W per Table 7 below.

Therefore, T_j for an ambient temperature of 70°C with all outputs switching is:

$$70^\circ\text{C} + 0.155\text{W} * 42.4^\circ\text{C/W} = 76.6^\circ\text{C}. \text{ This is well below the limit of } 125^\circ\text{C}.$$

This calculation is only an example. T_j will obviously vary depending on the number of loaded outputs, supply voltage, air flow, and the type of board (single layer or multi-layer).

TABLE 7. THERMAL RESISTANCE θ_{JA} FOR 32-LEAD VFQFN, FORCED CONVECTION

θ_{JA} by Velocity (Meters per Second)			
	0	1	2.5
Multi-Layer PCB, JEDEC Standard Test Boards	42.4°C/W	37.0°C/W	33.2°C/W

RELIABILITY INFORMATION

TABLE 8. θ_{JA} vs. AIR FLOW TABLE FOR 32 LEAD VFQFN

θ_{JA} by Velocity (Meters per Second)			
	0	1	2.5
Multi-Layer PCB, JEDEC Standard Test Boards	42.4°C/W	37.0°C/W	33.2°C/W

TRANSISTOR COUNT

The transistor count for ICS844204-245 is: 4599

PACKAGE OUTLINE - K SUFFIX FOR 32 LEAD VFQFN

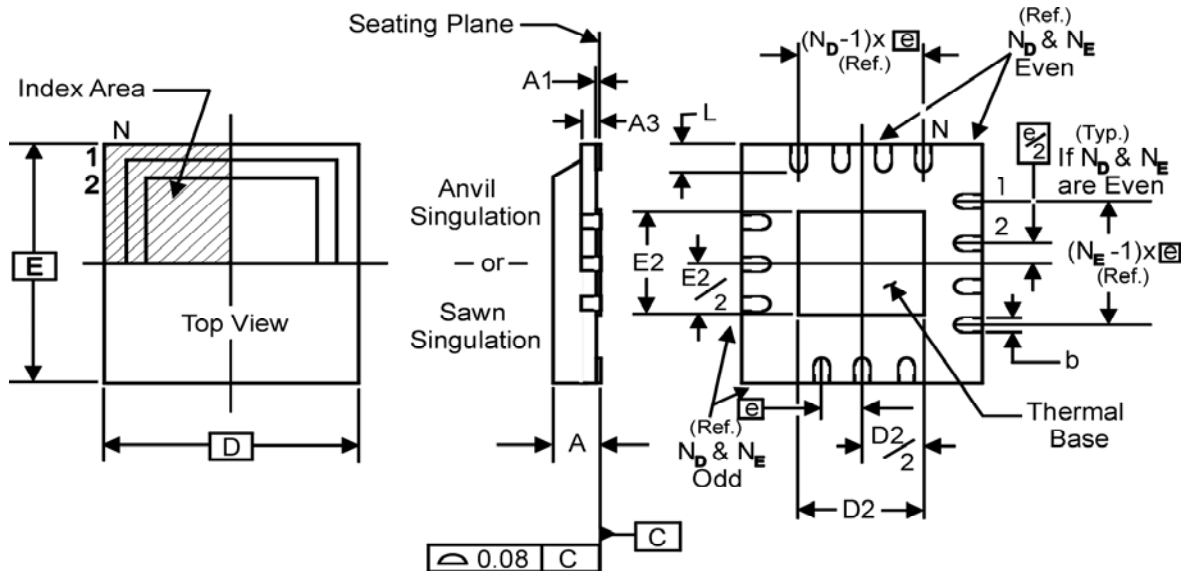

TABLE 9. PACKAGE DIMENSIONS

JEDEC VARIATION ALL DIMENSIONS IN MILLIMETERS			
SYMBOL	VHHD-2		
	MINIMUM	NOMINAL	MAXIMUM
N	32		
A	0.80	--	1.00
A1	0	--	0.05
A3	0.25 Ref.		
b	0.18	0.25	0.30
N _D			8
N _E			8
D	5.00 BASIC		
D2	1.25	2.25	3.25
E	5.00 BASIC		
E2	1.25	2.25	3.25
e	0.50 BASIC		
L	0.30	0.40	0.50

Reference Document: JEDEC Publication 95, MO-220

TABLE 10. ORDERING INFORMATION

Part/Order Number	Marking	Package	Shipping Packaging	Temperature
ICS844204BK-245	TBD	32 Lead VFQFN	tray	0°C to 70°C
ICS844204BK-245T	TBD	32 Lead VFQFN	2500 tape & reel	0°C to 70°C
ICS844204BK-245LF	ICS404B245L	32 Lead "Lead-Free" VFQFN	tray	0°C to 70°C
ICS844204BK-245LFT	ICS404B245L	32 Lead "Lead-Free" VFQFN	2500 tape & reel	0°C to 70°C

NOTE: Parts that are ordered with an "LF" suffix to the part number are the Pb-Free configuration and are RoHS compliant.

While the information presented herein has been checked for both accuracy and reliability, Integrated Device Technology, Incorporated (IDT) assumes no responsibility for either its use or for infringement of any patents or other rights of third parties, which would result from its use. No other circuits, patents, or licenses are implied. This product is intended for use in normal commercial applications. Any other applications such as those requiring extended temperature ranges, high reliability or other extraordinary environmental requirements are not recommended without additional processing by IDT. IDT reserves the right to change any circuitry or specifications without notice. IDT does not authorize or warrant any IDT product for use in life support devices or critical medical instruments.

Innovate with IDT and accelerate your future networks. Contact:

www.IDT.com

For Sales

800-345-7015
408-284-8200
Fax: 408-284-2775

For Tech Support

netcom@idt.com
480-763-2056

Corporate Headquarters

Integrated Device Technology, Inc.
6024 Silver Creek Valley Road
San Jose, CA 95138
United States
800 345 7015
+408 284 8200 (outside U.S.)

Asia Pacific and Japan

Integrated Device Technology
Singapore (1997) Pte. Ltd.
Reg. No. 199707558G
435 Orchard Road
#20-03 Wisma Atria
Singapore 238877
+65 6 887 5505

Europe

IDT Europe, Limited
321 Kingston Road
Leatherhead, Surrey
KT22 7TU
England
+44 (0) 1372 363 339
Fax: +44 (0) 1372 378851



www.IDT.com