

DO NOT SCALE FROM THIS PRINT

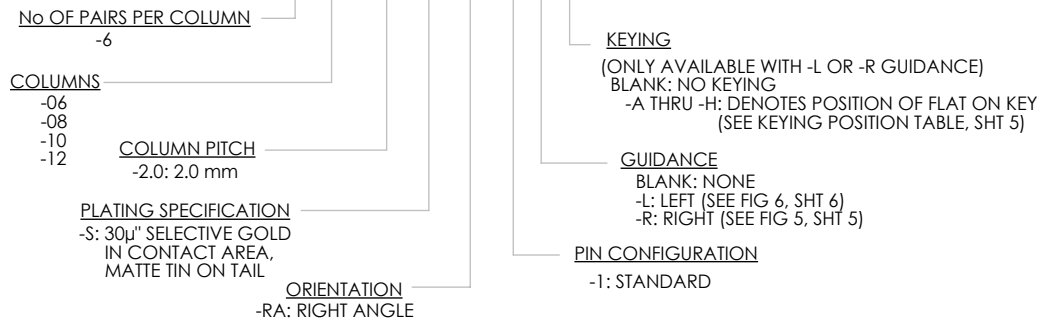

(** = NOT RELEASED)

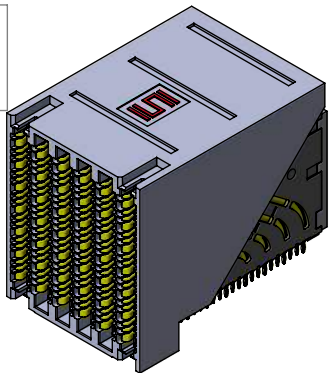
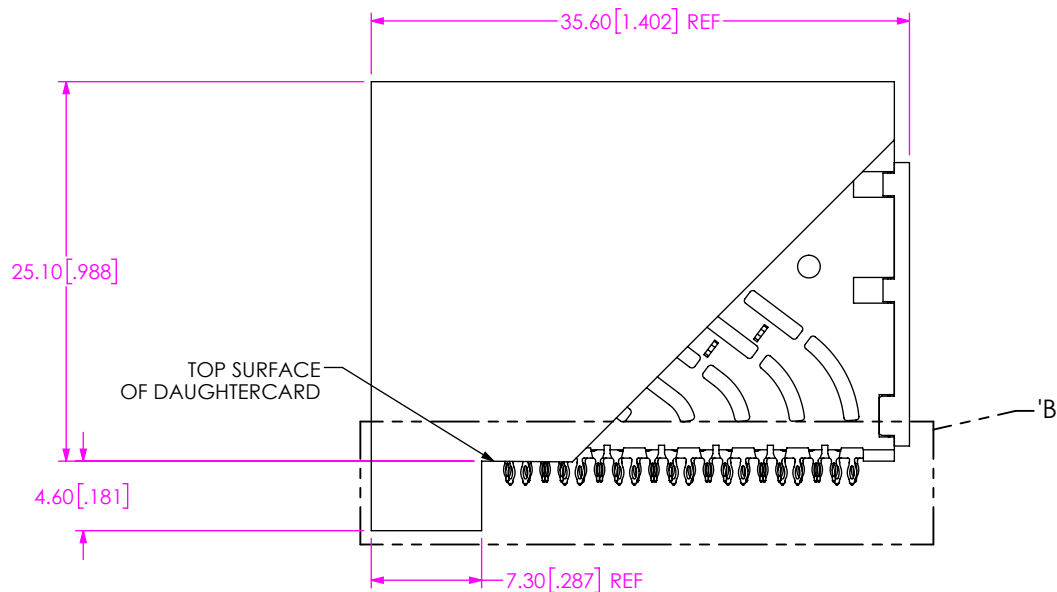
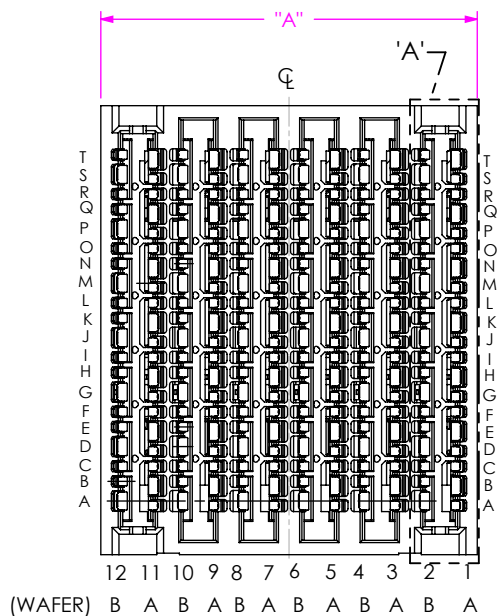

FIG 1
EBTF-6-12-2.0-X-RA-1 SHOWN

TABLE 1				
COLUMNS	"A"	"B"	"C"	
-06	12.90 [0.508]	10.00 [0.394]	5.20 [0.205]	
-08	16.90 [0.665]	14.00 [0.551]	7.20 [0.283]	
-10	20.90 [0.823]	18.00 [0.709]	9.20 [0.362]	
-12	24.90 [0.980]	22.00 [0.866]	11.20 [0.441]	

NOTES:

1. MINIMUM PUSHOUT FORCE: 2.22N [.5 LB].
2. CONTACT SAMTEC FOR CONNECTOR PRESS FIT INSTRUCTIONS.
3. TRAYS TO BE STANDARD PACKAGING.
4. ORDERS WILL BE PACKAGED ACCORDING TO THE SAMTEC PACKAGING EFFICIENCY STANDARDS (SPES) FOUND ON WWW.SAMTEC.COM

<p>UNLESS OTHERWISE SPECIFIED, DIMENSIONS ARE IN MILLIMETERS [INCHES]. TOLERANCES ARE:</p> <p>DECIMALS ANGLES</p> <p>X.X: ±0.3 [.01] 2°</p> <p>X.XX: ±0.10 [.004]</p> <p>X.XXX: ±0.050 [.0019]</p>	<p>PROPRIETARY NOTE</p> <p>THIS DOCUMENT CONTAINS CONFIDENTIAL AND PROPRIETARY INFORMATION AND ALL DESIGN, MANUFACTURING, REPRODUCTION, USE, PATENT RIGHTS AND SALES RIGHTS ARE EXPRESSLY RESERVED BY SAMTEC, INC. THIS DOCUMENT SHALL NOT BE DISCLOSED, IN WHOLE OR PART, TO ANY UNAUTHORIZED PERSON OR ENTITY NOR REPRODUCED, TRANSFERRED OR INCORPORATED IN ANY OTHER PROJECT IN ANY MANNER WITHOUT THE EXPRESS WRITTEN CONSENT OF SAMTEC, INC.</p>	<p>520 PARK EAST BLVD., NEW ALBANY, IN 47150 PHONE: 812-944-6733 FAX: 812-948-5047 e-Mail: info@SAMTEC.com code 53322</p>

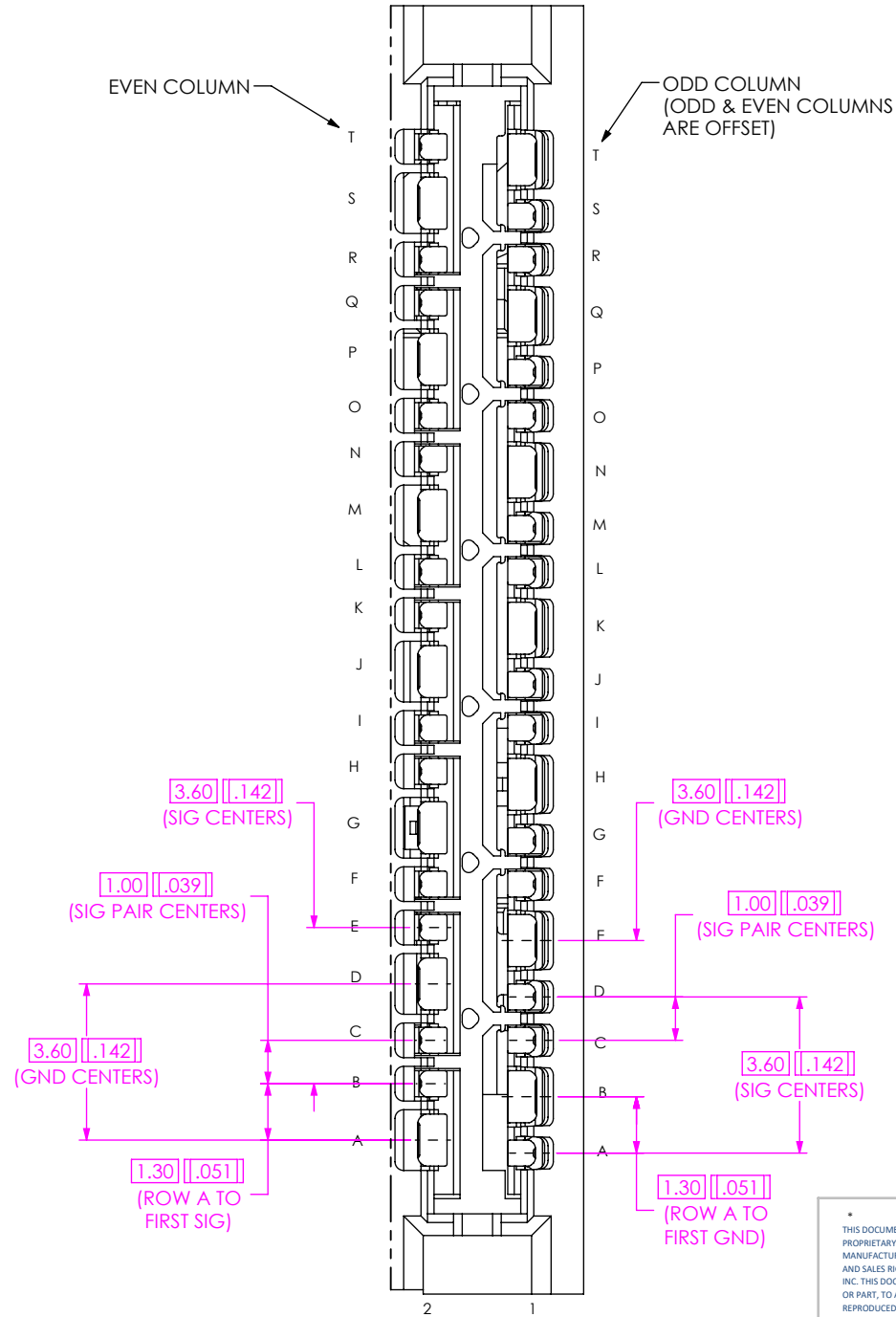

EVEN COLUMN

ODD COLUMN
(ODD & EVEN COLUMNS
ARE OFFSET)

DETAIL 'A'
SCALE 6 : 1

PROPRIETARY NOTE
THIS DOCUMENT CONTAINS CONFIDENTIAL AND PROPRIETARY INFORMATION AND ALL DESIGN, MANUFACTURING, REPRODUCTION, USE, PATENT RIGHTS AND SALES RIGHTS ARE EXPRESSLY RESERVED BY SAMTEC, INC. THIS DOCUMENT SHALL NOT BE DISCLOSED, IN WHOLE OR PART, TO ANY UNAUTHORIZED PERSON OR ENTITY NOR REPRODUCED, TRANSFERRED OR INCORPORATED IN ANY OTHER PROJECT IN ANY MANNER WITHOUT THE EXPRESS WRITTEN CONSENT OF SAMTEC, INC.

DO NOT SCALE DRAWING

SHEET SCALE: 2:1



520 PARK EAST BLVD. NEW ALBANY, IN 47150
PHONE: 812-944-6733 FAX: 812-948-5047
e-Mail info@SAMTEC.com code 55322

DESCRIPTION:
EXAMAX™ RIGHT ANGLE RECEPTACLE ASSEMBLY

DWG. NO.
EBTF-6-XX-2.0-X-RA-X-X-X

BY: J. BROWNING 11/19/2014 SHEET 2 OF 5

TOP SURFACE OF DAUGHTERCARD

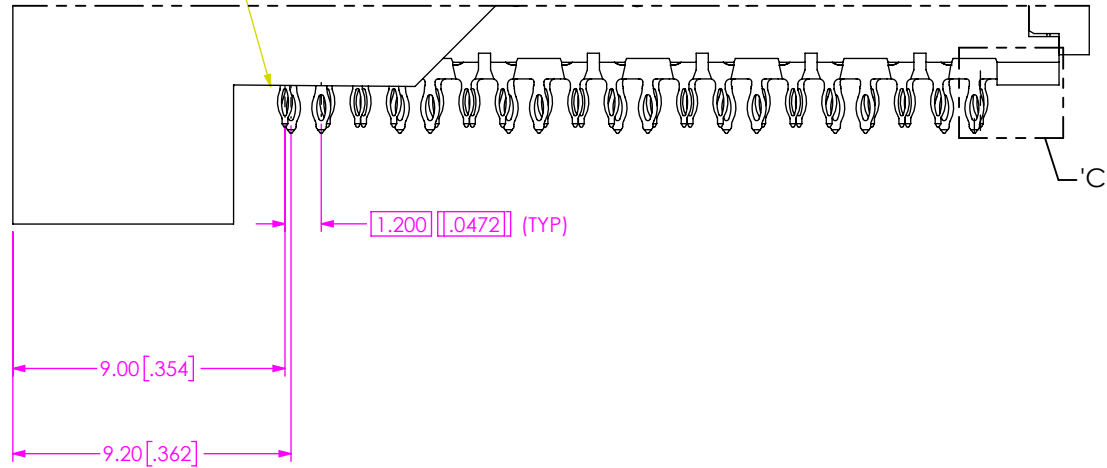

DETAIL 'B'
SCALE 4 : 1

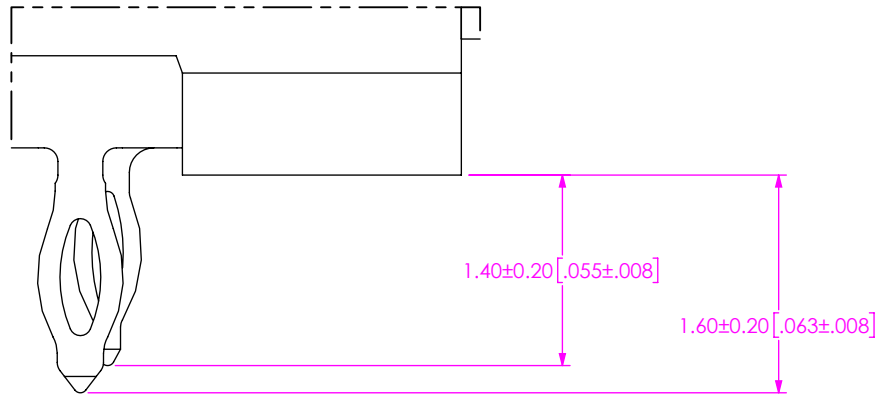

DETAIL 'C'
SCALE 18 : 1

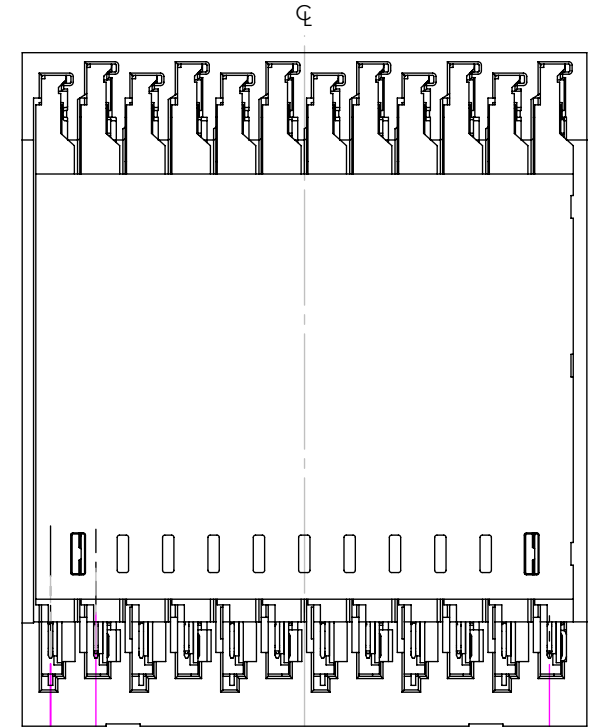

BACK VIEW

PROPRIETARY NOTE
THIS DOCUMENT CONTAINS CONFIDENTIAL AND PROPRIETARY INFORMATION AND ALL DESIGN, MANUFACTURING, REPRODUCTION, USE, PATENT RIGHTS AND SALES RIGHTS ARE EXPRESSLY RESERVED BY SAMTEC, INC. THIS DOCUMENT SHALL NOT BE DISCLOSED, IN WHOLE OR PART, TO ANY UNAUTHORIZED PERSON OR ENTITY NOR REPRODUCED, TRANSFERRED OR INCORPORATED IN ANY OTHER PROJECT IN ANY MANNER WITHOUT THE EXPRESS WRITTEN CONSENT OF SAMTEC, INC.

DO NOT SCALE DRAWING

SHEET SCALE: 3:1

samtec

520 PARK EAST BLVD, NEW ALBANY, IN 47150
PHONE: 812-944-6733 FAX: 812-948-5047
e-Mail info@SAMTEC.com code 55322

DESCRIPTION:
EXAMAX™ RIGHT ANGLE RECEPTACLE ASSEMBLY

DWG. NO.
EBTF-6-XX-2.0-X-RA-X-X-X

BY: J. BROWNING 11/19/2014 SHEET 3 OF 5

TABLE 2			
COLUMNS	"D"	"E"	
-06	18.85 [0.742]	9.20	[0.362]
-08	22.85 [0.900]	11.20	[0.441]
-10	26.85 [1.057]	13.20	[0.520]
-12	30.85 [1.215]	15.20	[0.598]

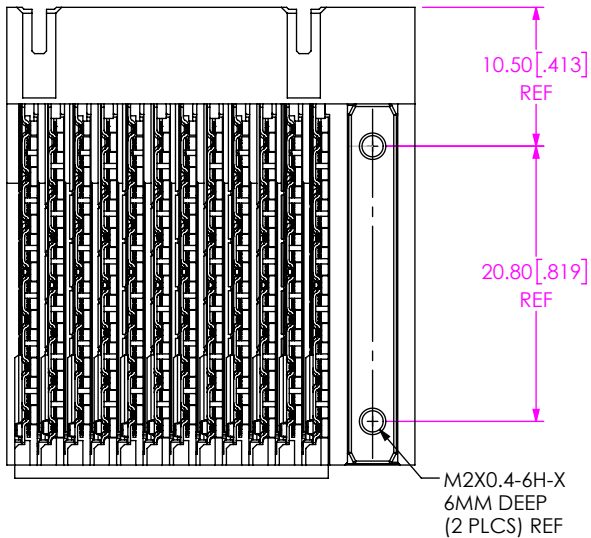
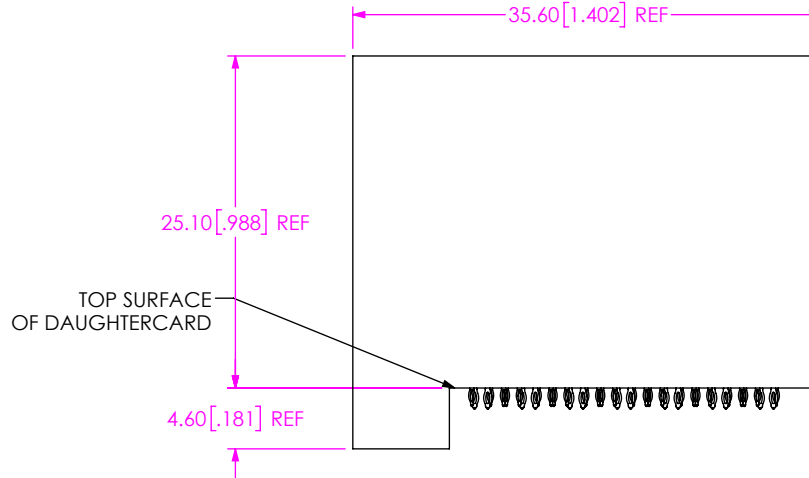
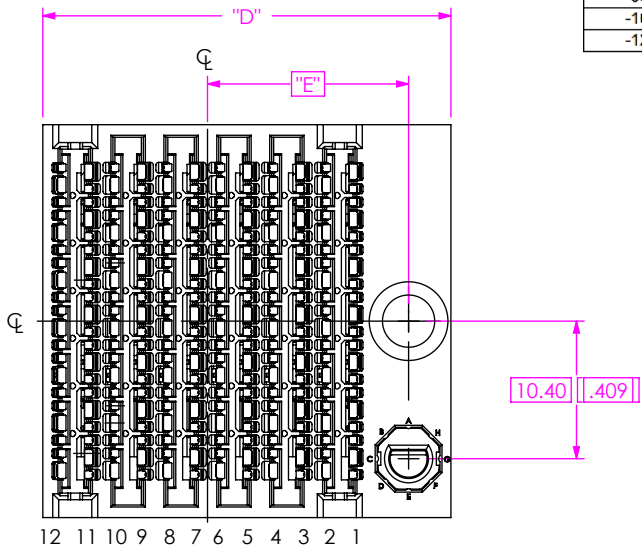

FIG 5
RIGHT GUIDANCE
EBTF-6-12-2.0-X-RA-X-R-A SHOWN
(DIFFERENT AS SHOWN, OTHERWISE SAME AS FIG 1)

KEYING POSITION TABLE

		KEYING							
		-A	-B	-C	-D	-E	-F	-G	-H
-R / -L									

PROPRIETARY NOTE
THIS DOCUMENT CONTAINS CONFIDENTIAL AND PROPRIETARY INFORMATION AND ALL DESIGN, MANUFACTURING, REPRODUCTION, USE, PATENT RIGHTS AND SALES RIGHTS ARE EXPRESSLY RESERVED BY SAMTEC, INC. THIS DOCUMENT SHALL NOT BE DISCLOSED, IN WHOLE OR PART, TO ANY UNAUTHORIZED PERSON OR ENTITY NOR REPRODUCED, TRANSFERRED OR INCORPORATED IN ANY OTHER PROJECT IN ANY MANNER WITHOUT THE EXPRESS WRITTEN CONSENT OF SAMTEC, INC.

DO NOT SCALE DRAWING

SHEET SCALE: 1.75:1



520 PARK EAST BLVD. NEW ALBANY, IN 47150
PHONE: 812-944-6733 FAX: 812-948-5047
e-Mail info@SAMTEC.com code 55322

DESCRIPTION:
EXAMAX™ RIGHT ANGLE RECEPTACLE ASSEMBLY

DWG. NO.
EBTF-6-XX-2.0-X-RA-X-X-X

BY: J. BROWNING 11/19/2014 SHEET 4 OF 5

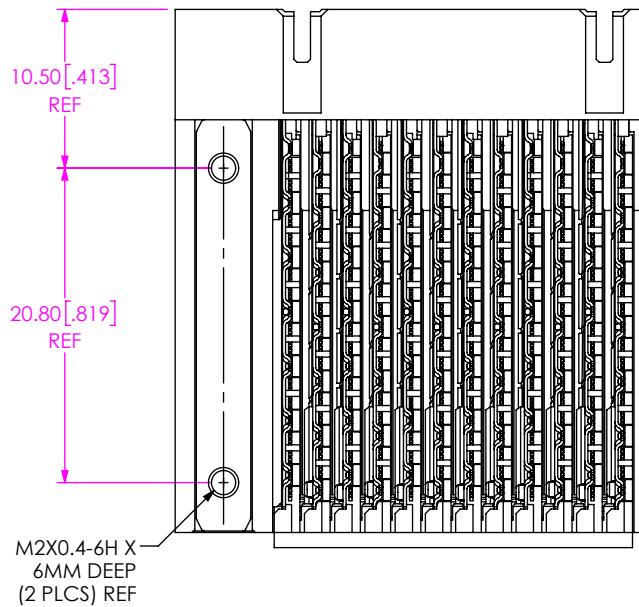
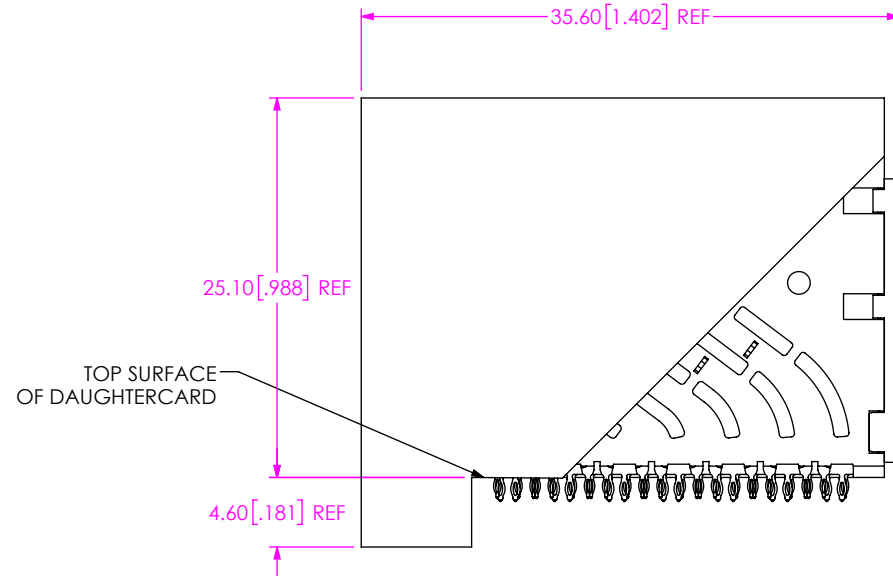
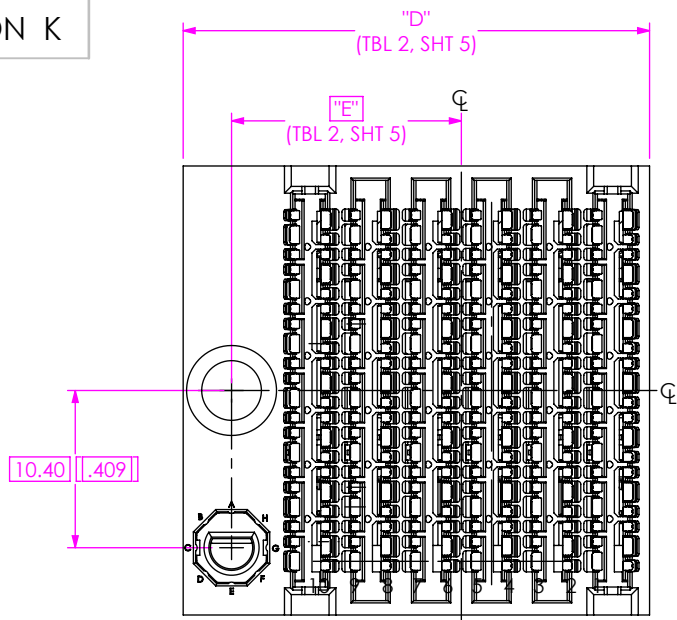

FIG 6
LEFT GUIDANCE
EBTF-6-12-2.0-X-RA-X-L-A SHOWN
(DIFFERENT AS SHOWN, OTHERWISE SAME AS FIG 5)

PROPRIETARY NOTE
THIS DOCUMENT CONTAINS CONFIDENTIAL AND PROPRIETARY INFORMATION AND ALL DESIGN, MANUFACTURING, REPRODUCTION, USE, PATENT RIGHTS AND SALES RIGHTS ARE EXPRESSLY RESERVED BY SAMTEC, INC. THIS DOCUMENT SHALL NOT BE DISCLOSED, IN WHOLE OR PART, TO ANY UNAUTHORIZED PERSON OR ENTITY NOR REPRODUCED, TRANSFERRED OR INCORPORATED IN ANY OTHER PROJECT IN ANY MANNER WITHOUT THE EXPRESS WRITTEN CONSENT OF SAMTEC, INC.

DO NOT SCALE DRAWING

SHEET SCALE: 2:1



520 PARK EAST BLVD, NEW ALBANY, IN 47150
PHONE: 812-944-6733 FAX: 812-948-5047
e-Mail info@SAMTEC.com code 55322

DESCRIPTION:
EXAMAX™ RIGHT ANGLE RECEPTACLE ASSEMBLY

DWG. NO.
EBTF-6-XX-2.0-X-RA-X-X-X

BY: J. BROWNING 11/19/2014 SHEET 5 OF 5