

DTA04



Motor thermistor relay



Benefits

- **High operating safety.** The thresholds are determined by the Motor PTC. Beyond the specified temperature the output stops the motor/s.
- **Save time and costs.** There is no need to connect other additional and expensive controllers.
- **Ensure continuous production process in your plant.** This type of controller allows limitation of false alarms which may be the cause of useless interruptions of production systems.
- **Two outputs.** The 2 outputs provide, besides interrupting the the Motor supply, an additional signal for a lamp, PC or PLC.
- **Bi-colour front LED.** These devices indicate alarms for temperature and PTC.

Description

DTA04 is a motor thermistor monitoring relay. Through the motor internal PTC or PTCs the DTA detects when one or more motor windings are exceeding the maximum operating winding temperature.

The PTC type installed in the motor is different according to the motor insulation temperature. The temperature triggering threshold is determined by the PTC Type.

The relay is equipped with 2 outputs which operate in a complementary mode.

The DTA04 can be set to operate as MANUAL or AUTO reset.

When set to manual, the front LED will notify when the motor temperature is back to normal avoiding to try to restore operation uselessly.

Applications

This product is extremely suitable for pumps temperature monitoring. It can be useful in all applications where motors are used especially where overloads are frequent and may cause motor damages: pumping stations, water treatment, conveyors, material handling, HVAC, chillers. etc.

Structure

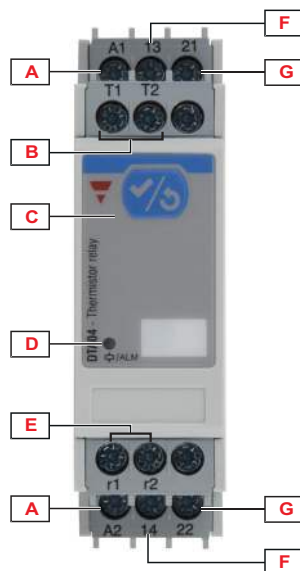

Element	Component	Function
A	Power Supply terminals	A1 (+ or L) A2 (- or N)
B	PTC input	Up to 6 PTCs in series can be connected
C	TEST / RESET pushbutton	When no overtemperature alarm is present, this double function pushbutton, operates as TEST by simulating the PTC overtemperature: motor stops as long as pushbutton is pressed, as soon as pushbutton is released the normal operation is restored. The pushbutton operates as RESET when the motor had been stopped by overtemperature, the setting is for MANUAL reset and the LED shows the "Ready for reset" situation.
D	Information LED	Green ON steady: no alarm Red ON steady: over-temperature alarm Fast Red blinking: open circuit PTC Slow Red blinking: short-circuit Red and Green alternate: ready for reset
E	Remote RESET pushbutton terminals	To configure the device as Autoreset they shall be jumpered
F	Output 1 terminals	SPST electromechanical relay. During normal operation the contact is closed, it opens when an alarm is triggered
G	Output 2 terminals	SPST Electromechanical relay. Normally open contact, it closes when an alarm is triggered

Features

General

Material	PA66 or Noryl
Assembly	DIN rail mounting (According to EN 50022)
Protection grade	IP20
Weight	150 g
Terminals	Screw terminals. AWG30 to AWG14 (0.05 mm ² to 2.08 mm ²) stranded or solid

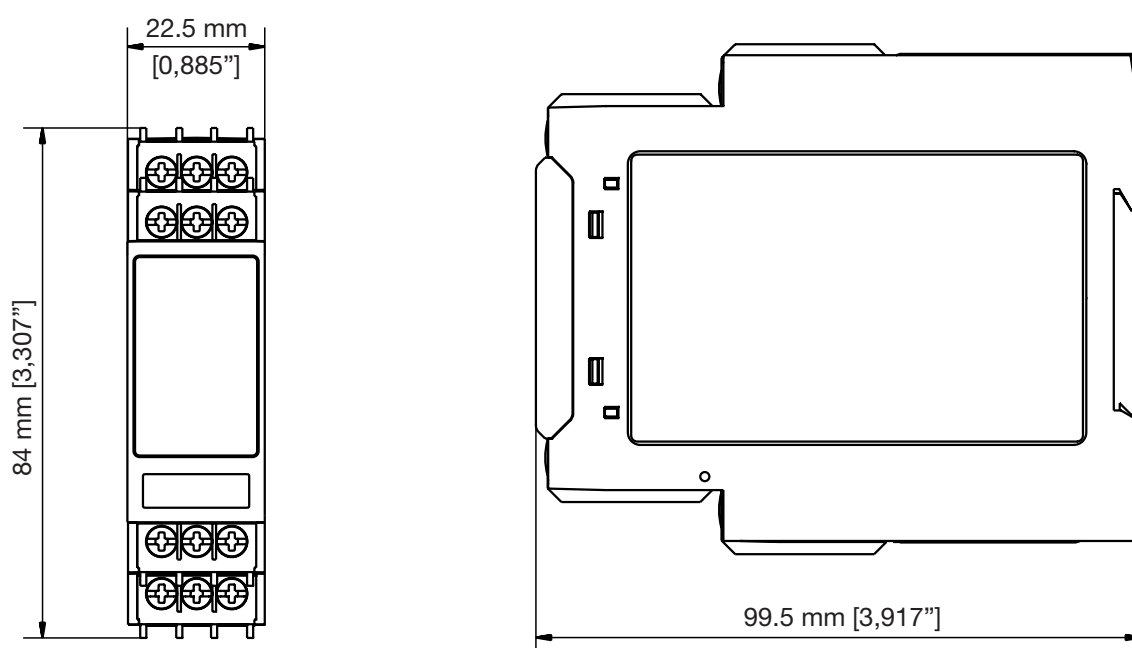

Power supply

Power supply	18 to 265 Vac/Vdc: 45 to 65 Hz, or dc
Consumption	3VA (AC supply) / 1.5W (DC supply)

Environmental

Working temperature	-25° C to 60° C (-13° F to 140° F)
Storage temperature	-40° C to 80° C (-40° F to 176° F)
Relative humidity	5-95% non condensing
Pollution degree	2
Operating max altitude	2000 m amsl (6560ft)
Salinity	No saline environment
UV resistance	No UV exposure

Compatibility and conformity

Standard compliance	EN60255-6
Approvals	 (UL 508, CSA 22.2,)
CE Marking	L.V. Directive EN60947-5-1, EMC Directive EN 60947-8

Inputs

Measuring ranges	
Resistance measuring	Input from a series of 1 to 6 PTC according to EN44081 or IEC34-11-2
Cable length	Max. 600m (wire 1.5mm ²) or 200m (wire 0.5mm ²)

Alarm detection	
Over-temperature trip	> 3600 Ω
Over-temperature reset	< 1580 Ω
Short-circuit protection	14 Ω (reset 16 Ω)
Open circuit detection	20 k Ω (reset < 18 k Ω)
Switching frequency	< 1Hz
Refresh time	500 ms

Outputs

Type	2 x SPST NO electromechanical relay
Logic Output 1 Output 2	De-energized on alarm Energized on alarm
Contact rating	NEMA B 300 240 Vac AC1 8 A @ 250 Vac DC12 5 A @ 24 Vdc AC15 2.5 A @ 250 Vac DC13 2.5 A @ 24 Vdc

Insulation

Basic Insulation	
Inputs to output 1	2.5kVrms, 4kV impulse 1.2/50us
Inputs to output 2	2.5kVrms, 4kV impulse 1.2/50us
Inputs to supply	2.5kVrms, 4kV impulse 1.2/50us
Output 1 to supply	2.5kVrms, 4kV impulse 1.2/50us
Output 2 to supply	2.5kVrms, 4kV impulse 1.2/50us
Output 1 to output 2	2.5kVrms, 4kV impulse 1.2/50us

Operating diagram

When the temperature of one of the PTCs in series is exceeded output relays will both switch: relay 1 is de-energized and output relay 2 is energised. The LED is ON red.

When the motor normal temperature is restored, if the DTA04 is wired as "Auto reset", the operation is restarted automatically.

If the DTA04 is wired as manual reset when the normal motor temperature is restored the LED starts blinking alternatively red and green indicating it is ready for reset. When the front or the remote RESET buttons are pressed the operation starts again. The LED turns to green and the output relays switch back to original position.

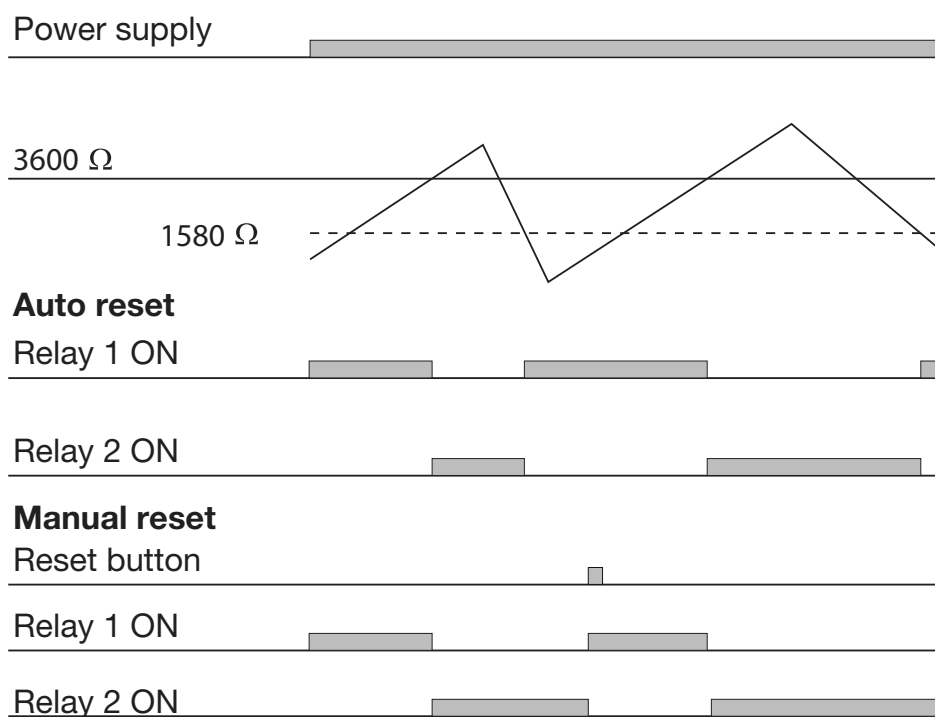

Connection Diagrams

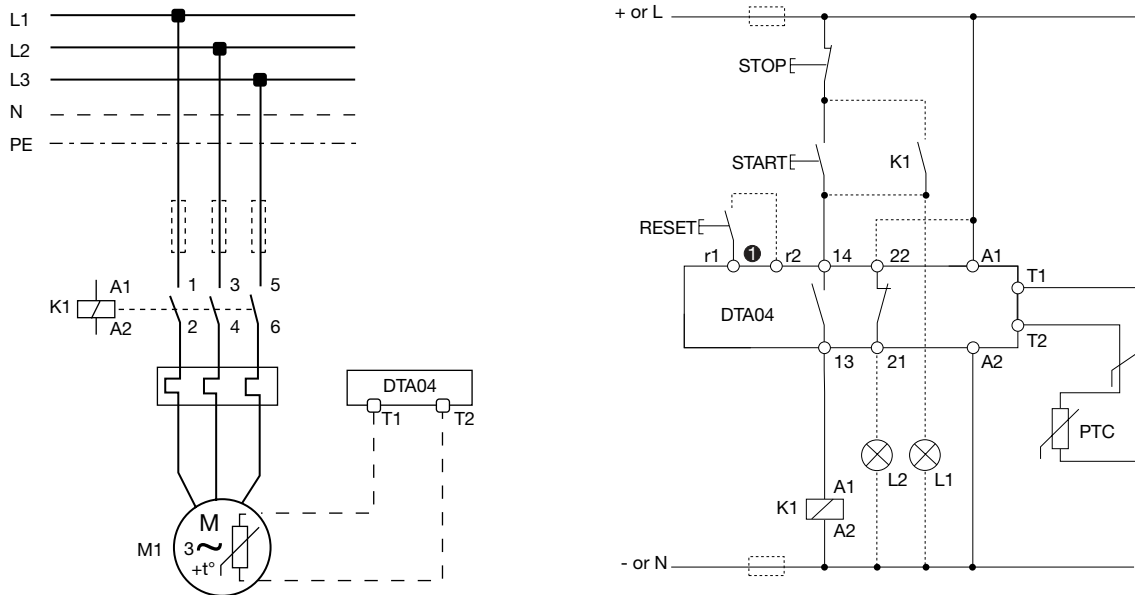

Code	Description
K1	Main contactor
START	Machine start pushbutton
STOP	Machine stop pushbutton
RESET	Remote reset button
L1	Green Lamp (OK)
❶	For Auto Reset operation r1 and r2 shall be jumpered

References

Order code



DTA04DM24

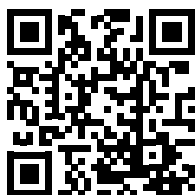

COPYRIGHT ©2016
Content subject to change. Download the PDF: www.productselection.net