

SIGN	DATE	DESCRIPTION	APPROVER
THIS IS CAD DRAWING, DO NOT REVISE MANUALLY!!!			

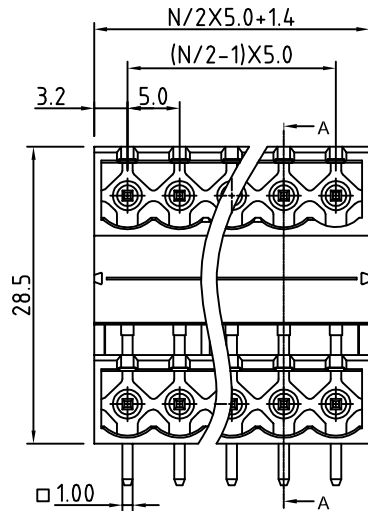

N=NUMBER OF POLES

P.C.B LAYOUT

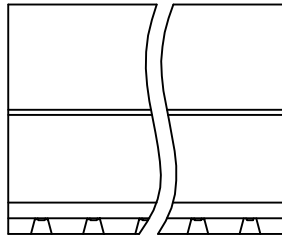
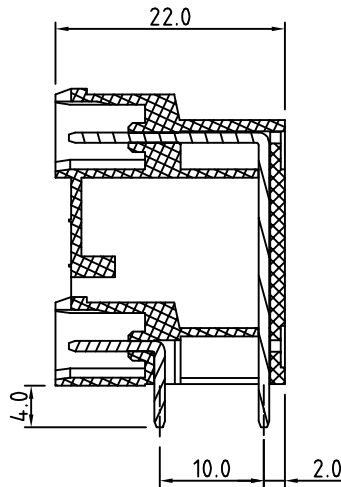
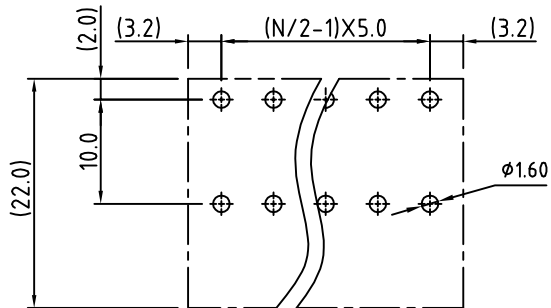

SEC A-A

Material

- Terminal body (Contact pin): Brass Whit Tin plated
- Insulator (housing): Thermoplastic (UL94V-0)

Electrical cULus

- Voltage rating: 300VAC
- Current rating: 20A
- Withstanding Voltage: 1.6KV
- Operating temperature: -30°C to +105°C
- Soldering temperature: 250°C±10°C/5 Sec
- Safety Approval: cULus

RoHS Compliant

PART NUMBER:

OSTVLXX7151

No. of Poles

- 04: 2x02 Poles
- 06: 2x03 Poles
- :
- 48 2x24 Poles

COLOR

- 0: Black
- 5: Green (Standard)
- 6: Blue
- 8: Grey



THESE DRAWINGS AND SPECIFICATIONS ARE THE PROPERTY OF ON-SHORE TECHNOLOGY, INC. AND SHALL NOT BE REPRODUCED, COPIED OR USED IN ANY MANNER WITHOUT THE PRIOR WRITTEN CONSENT OF ON-SHORE TECHNOLOGY, INC.

TITLE		OSTVL-5.0mm Series closed right-angle 2x2p-2x24p			
PART NO.	OSTVLXX7151	DWG NO.	OSTVLXX7151.DWG		
APPROVED	CHECKED	DESIGNED	DRAWN	CUST NO.	Tolerance
Shi Jun 2006.10.23	Marvin 2006.10.23	Marvin 2006.10.23	Marvin 2006.10.23		X. ±0.50
				UNIT: mm	X.X ±0.30
				SCALE: NONE	X.XX ±0.10
				SHEET: 01/01	X° ±1°
				REV.: D	