

Component Image & Dimension

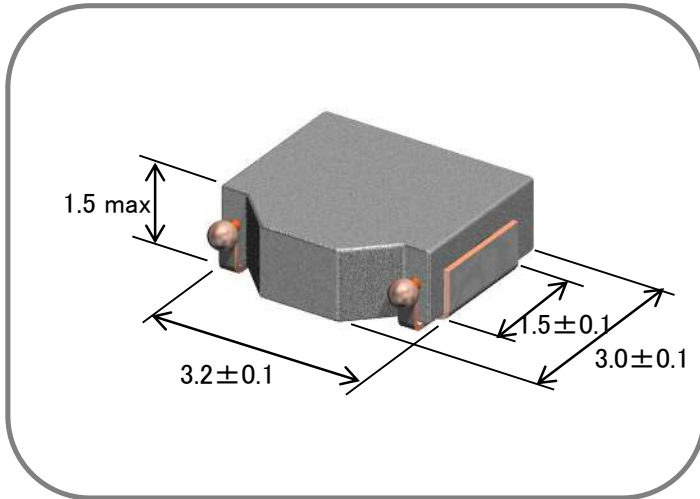

Features

- a) Small Footprint and Low Profile Design :
Footprint : 3.2 x 3.0 mm Typ.
Height : 1.5mm Max.
- b) High Power Handling Capability :
Small Copper Loss
Using Large Saturation Induction of Fe- based metals
- c) Flat inductance performance over temperature based on the high curie temperature of the iron powder core material.
- d) Automatic Mounting in Tape&Reel Package.

Applications

Note Book & Mobile Computer, VRM, Cellular Phone, HDD, Car accessories etc.

Electrical Specification (Provisional value)

TDK Identification	Inductance		Test Freq. (kHz)	DC Resistance		Rated DC Current		
	at 0A (uH)	Tol. (%)		Spec. (m-Ohm)	Typ. (m-Ohm)	Idc 1 (A) max.	(A) typ.	Idc 2 (A) typ.
SPM3015T- R47M-CA	0.47	+/-20%	100	34.5 max	31.4	6.1	8.1	4.3
SPM3015T- 1R0M-CA	1.0	+/-20%	100	52.9 max	48.1	5.1	6.8	3.5
SPM3015T- 1R5M-CA	1.5	+/-20%	100	73.1 max	66.4	3.5	4.7	3.0
SPM3015T- 2R2M-CA	2.2	+/-20%	100	97.4 max	88.5	3.0	4.0	2.6
SPM3015T- 3R3M-CA	3.3	+/-20%	100	151.9 max	138.0	2.4	3.2	2.0
SPM3015T- 4R7M-CA	4.7	+/-20%	100	218.2 max	198.3	2.1	2.8	1.8

Note. Idc 1 : Based on the inductance change.(-30% Reduction from Nominal L Value)

Idc 2 : Based on the self temperature rise. (+40 deg typ.)

Operating Temperature Range: -40 °C ~ +125 °C (including self temperature rise)

Caution: Please contact our sales person when you consider organic solvent or aqueous cleaning.

Inductance vs. DC Superposition

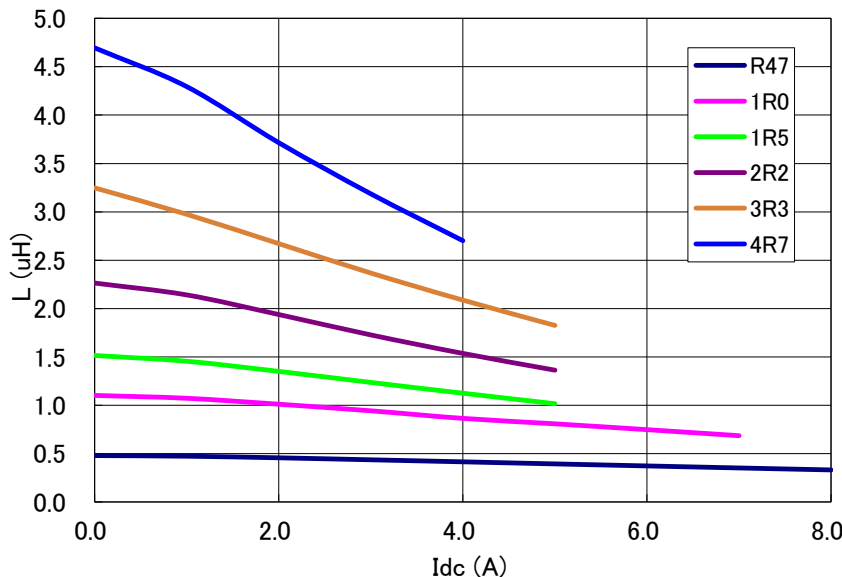

Recommended pad layout

