

Evaluation kit environment for L62xx family of dual brush DC and stepper motor drivers based on STM32 Nucleo

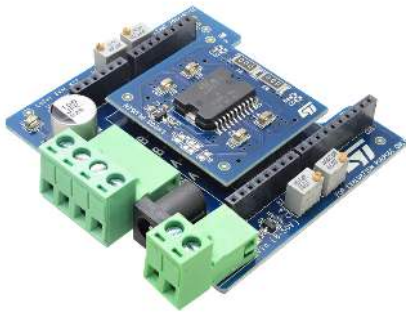

Features

- Voltage range from 8 V to 52 V
- Phase current up to 2.8 A r.m.s (with L6205, L6206, L6207 and L6208 devices) or 1.4 A r.m.s. (with L6225, L6226, L6227 and L6228 devices)
- Easy interchangeable plug-in boards for quick evaluation of the whole stepper and brush DC drivers of the L62xx family
- Programmable high-side overcurrent protection (L6206 and L6226 devices)
- Programmable OFF-time of the PWM current control (L6207, L6227, L6208 and L6228 devices)
- Compatible with Arduino UNO R3 connector
- RoHS compliant

Description

The [EVL62XX-MAIN](#) is an expansion board that can host small [EVL62XX-PLUG](#) plug-in boards for quick and easy evaluation of brush DC and stepper motor drivers of the L62xx family.

These boards provide an affordable and easy-to-use solution to drive dual brush DC and bipolar stepper motors in association with the evaluation software STSPIN Studio.

The EVL62XX-MAIN is compatible with the Arduino UNO R3 connector.

Product status link
EVL62XX-MAIN
EVL6205-PLUG
EVL6206-PLUG
EVL6207-PLUG
EVL6208-PLUG
EVL6225-PLUG
EVL6226-PLUG
EVL6227-PLUG
EVL6228-PLUG

1 Schematic diagrams

Figure 1. EVL62XX-MAIN

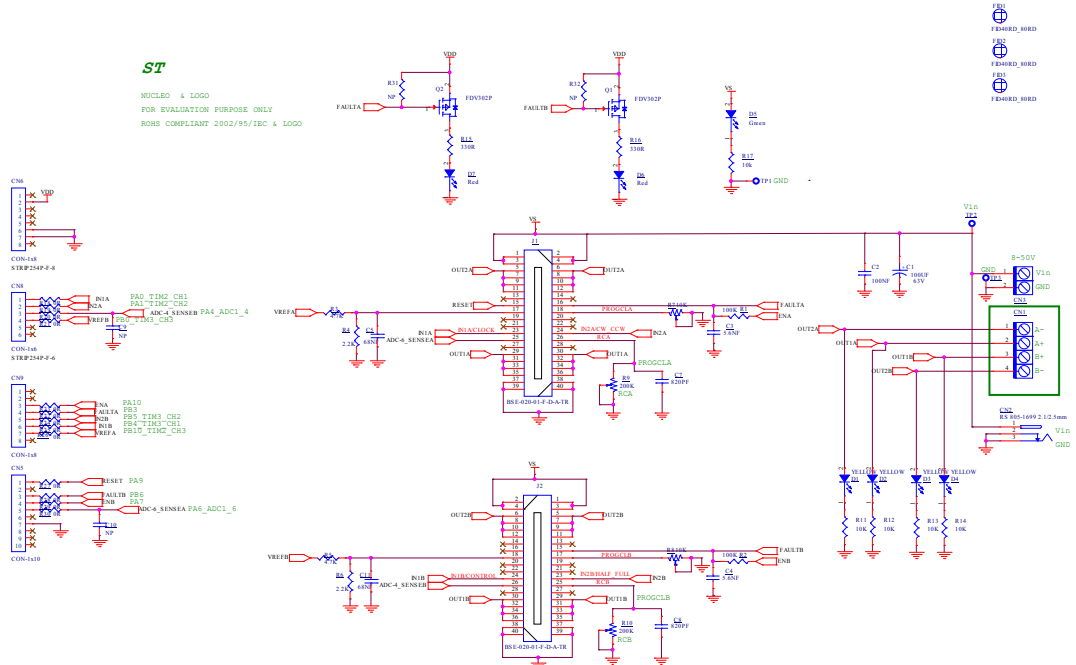

Figure 2. EVL6205-PLUG

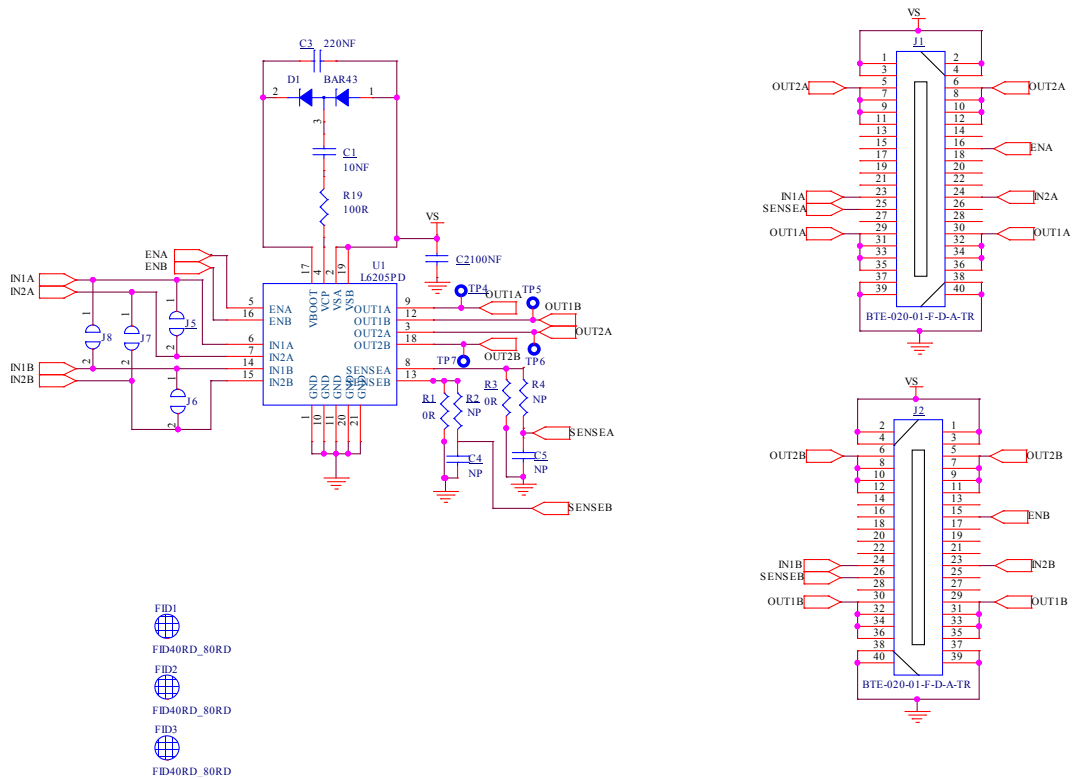

Figure 3. EVL6206-PLUG

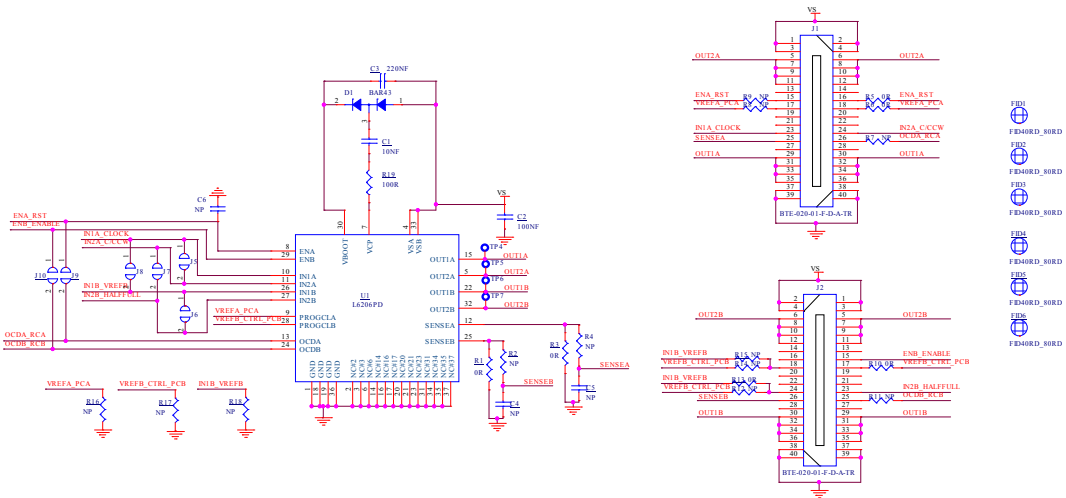

Figure 4. EVL6207-PLUG

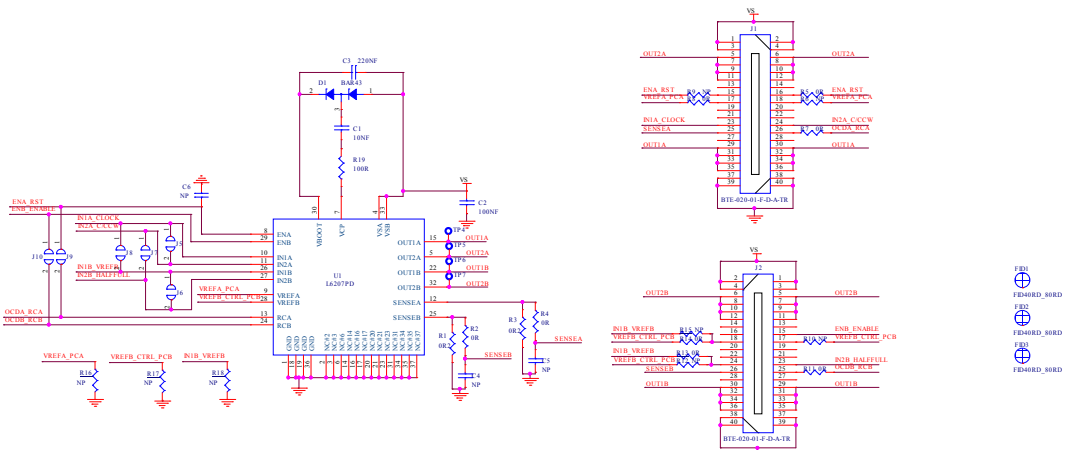

Figure 5. EVL6208-PLUG

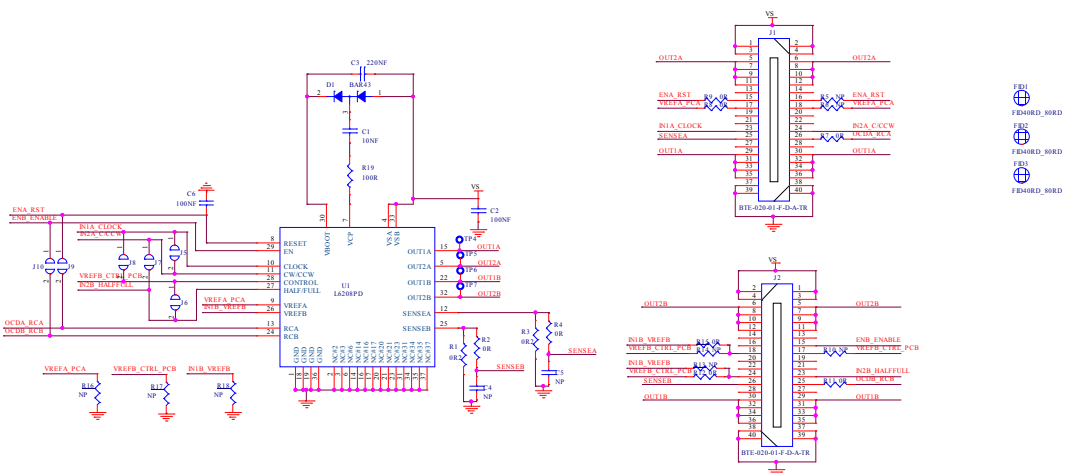

Figure 6. EVL6225-PLUG

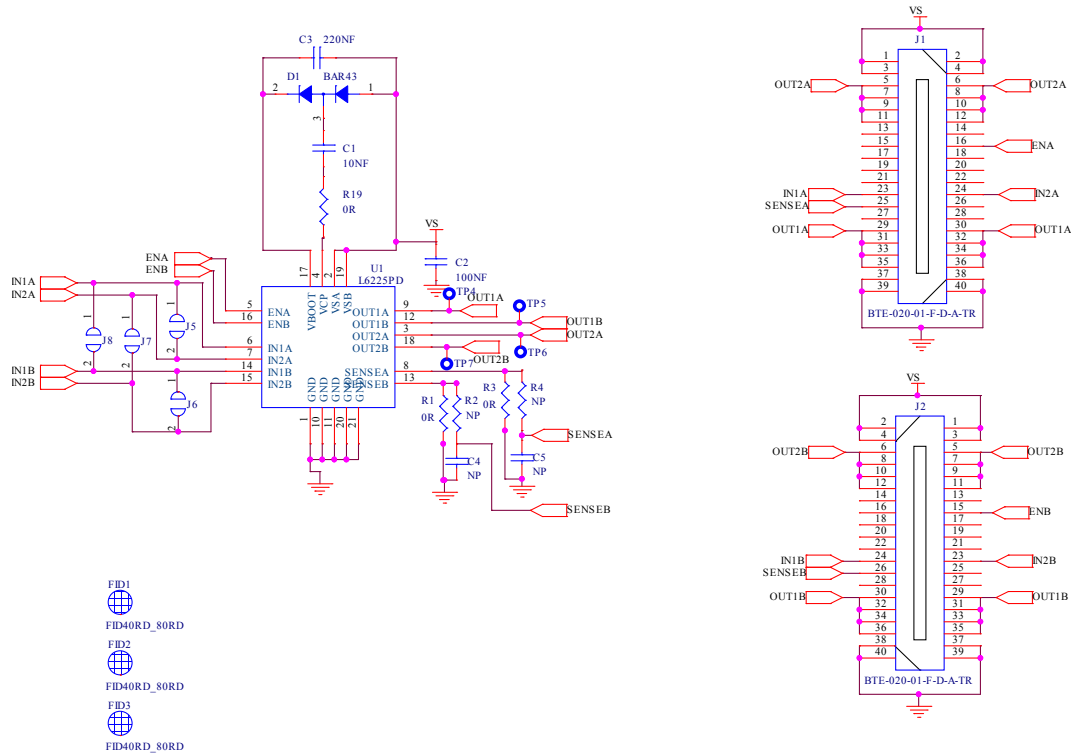

Figure 7. EVL6226-PLUG

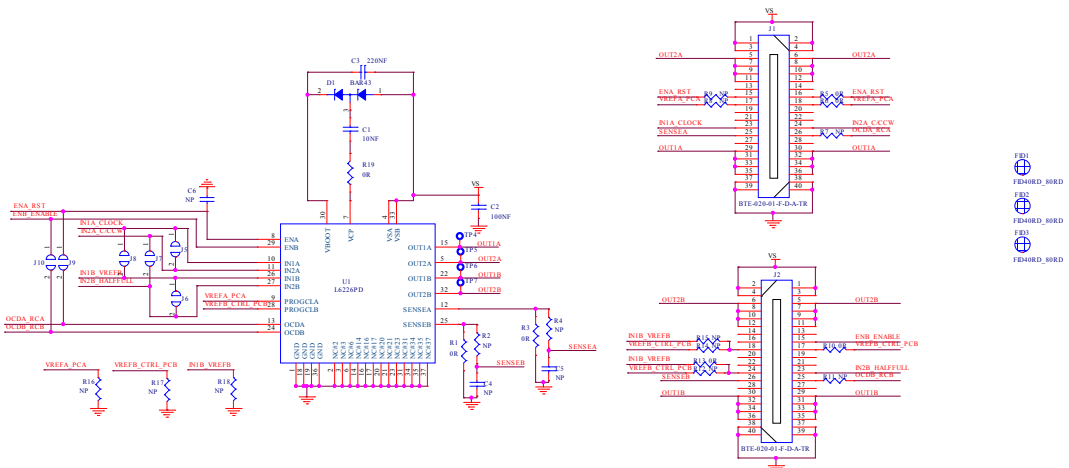

Figure 8. EVL6227-PLUG

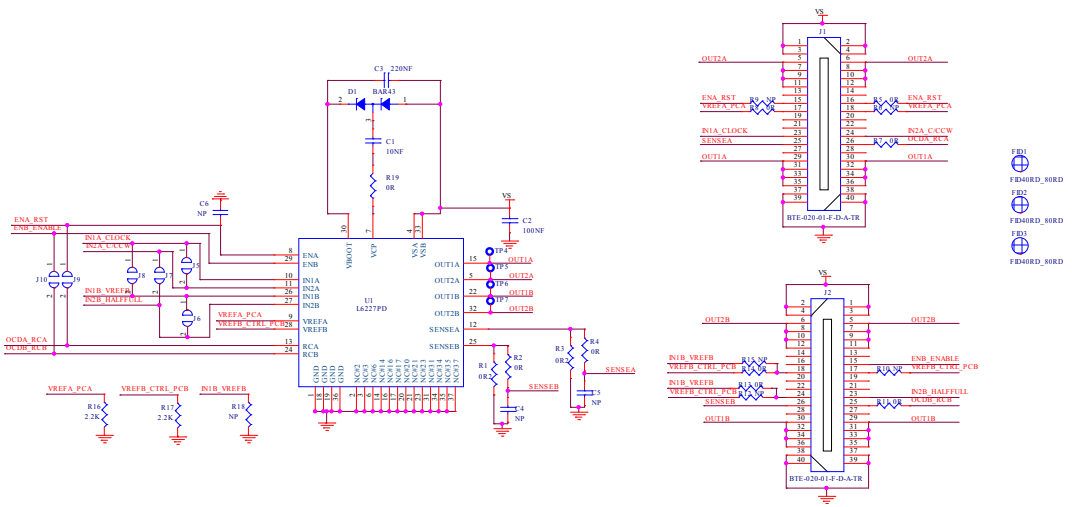
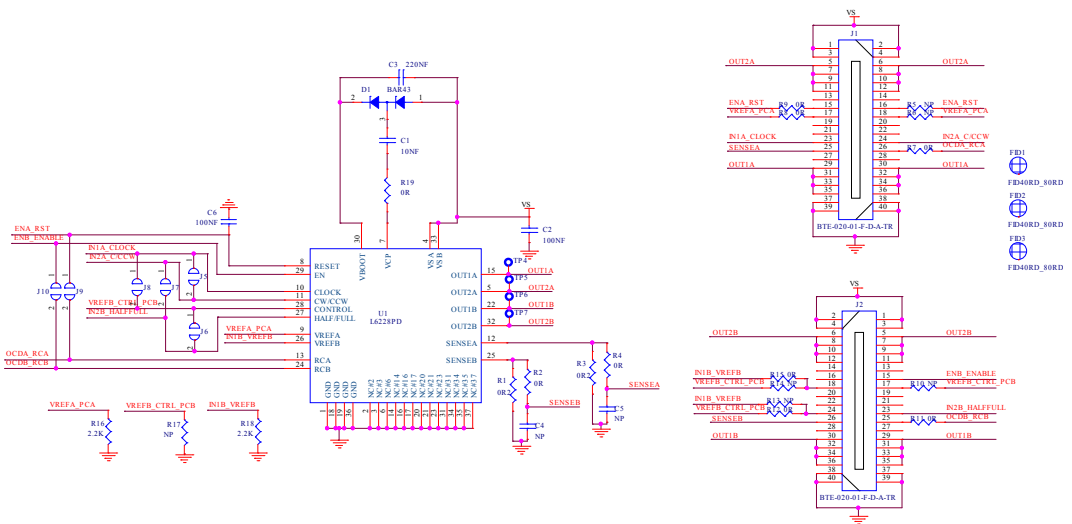

Figure 9. EVL6228-PLUG



Revision history

Table 1. Document revision history

Date	Version	Changes
01-Jul-2021	1	Initial release.



Contents

1 Schematic diagrams	2
Revision history	6
Contents	7

IMPORTANT NOTICE – PLEASE READ CAREFULLY

STMicroelectronics NV and its subsidiaries (“ST”) reserve the right to make changes, corrections, enhancements, modifications, and improvements to ST products and/or to this document at any time without notice. Purchasers should obtain the latest relevant information on ST products before placing orders. ST products are sold pursuant to ST’s terms and conditions of sale in place at the time of order acknowledgement.

Purchasers are solely responsible for the choice, selection, and use of ST products and ST assumes no liability for application assistance or the design of Purchasers’ products.

No license, express or implied, to any intellectual property right is granted by ST herein.

Resale of ST products with provisions different from the information set forth herein shall void any warranty granted by ST for such product.

ST and the ST logo are trademarks of ST. For additional information about ST trademarks, please refer to www.st.com/trademarks. All other product or service names are the property of their respective owners.

Information in this document supersedes and replaces information previously supplied in any prior versions of this document.

© 2021 STMicroelectronics – All rights reserved