

This document is the property of Amphenol Corporation and is delivered on the express condition that it is not to be disclosed, reproduced or used, in whole or in part, for manufacture or sale by anyone other than Amphenol Corporation without its prior consent, & that no right is granted to disclose or to use any information in this document.

CUSTOMER DRAWING

REVISIONS				
SYM	ECN	DESCRIPTION	DATE	APPROVED
3	CDXXXX	ADD PCB KEEP-OUT ZONE	Jun.09,2020	YH
4	CDXXXX	OPTIMIZED LATCH DESIGN	Sep.28,2020	YH
5	CD2387	DETAILED THE PN SYSTEM	Dec.22,2020	YH

NOTE:

- MATERIAL:**
HOUSING: HIGH TEMPERATURE THERMOPLASTIC; BLACK UL94-V0;HALOGEN FREE
CONTACT: COPPER ALLOY
BOARDLOCK: SPCC
- PLATING:**
CONTACT: MATING AREA: SEE PLATING SPEC OVER 1.27-2.54 UM NICKEL UNDERPLATED
SOLDER AREA: 2.54 UM MIN TIN OVER 1.27-2.54 UM NICKEL UNDERPLATED
BOARDLOCK: 2.54UM MIN TIN OVER 1.27-2.54UM NICKEL UNDERPLATED
- ELECTRICAL PERFORMANCE:**
RATED CURRENT FOR SIGNAL PIN: 0.7A/PIN;
RATED CURRENT FOR POWER PIN: 1.1A/PIN(A2/A3/A9/A10/B1/B2/B3/B8,TOTAL 8PIN).
- MATERIAL IS COMPLIANT TO RoHS
- TRANSMISSION SPEED:**
PCIe GEN 4/16Gbps : OPEN PIN FIELD DESIGN
PCIe GEN 5/32Gbps : CONFORM TO PCIe CEM SPECIFICATION
- MOISTURE SENSITIVITY LEVEL:1.
- ORDERING PART NUMBER: REFER TO THE PART NUMBER SYSTEM

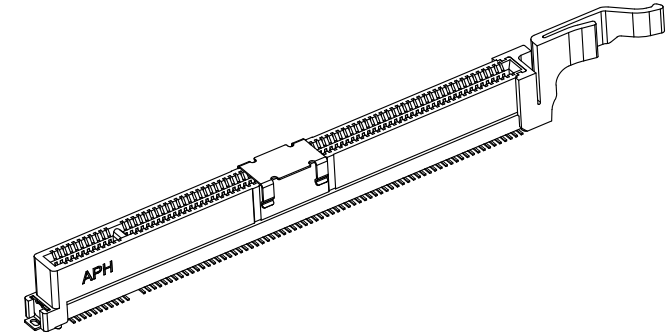

VIEW WITH CAP

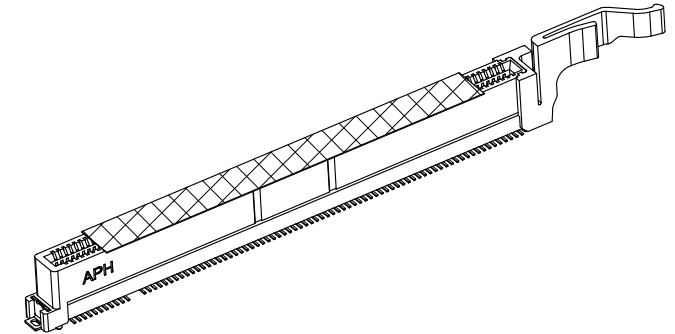

VIEW WITH MYLAR

PART NUMBER SYSTEM

CEE0164X1140XX X

PIN COUNT

164

CAP & MYLAR

0 CAP

1 MYLAR

PACKING TRAY

0 322.6x135.9MM;T2.0MM

PLATING SPEC

1 0.76um (30u'') Au

2 0.38um (15u'')Au

3 GOLD FLASH

4 GXT

TRANSMISSION SPEED

0 PCIe GEN5 / 32Gbps

1 PCIe GEN4 / 16Gbps

SOLDER TAIL LENGTH

2 STD TAIL

3 SHORTER TAIL



UNLESS OTHERWISE SPECIFIED TOLERANCES U.S. METRIC .X +/- 0.25 .XX +/- 0.20 .XXX +/- 0.15 FRACTIONS +/- ANGLES +/- 5° FOR MATERIALS AND FINISHES SEE NOTES	APPROVAL		DATE	Amphenol TITLE Cool Edge Connector 1.0mm pitch;PCIe X16;32&16G SIZE DRAWING NO. A3 C CEE0164X1140XXX SCALE NONE SHEET 1 OF 5
	DRAWN	Jun.Fan	Dec.22,2020	
	CHECKED			
	APPROVED			
REMOVE SHARP EDGES	ANGLE OF PROJECTION			
DIMENSIONS				
U.S. INCHES				
METRIC (mm)				

This document is the property of Amphenol Corporation and is delivered on the express condition that it is not to be disclosed, reproduced or used, in whole or in part, for manufacture or sale by anyone other than Amphenol Corporation without its prior consent, & that no right is granted to disclose or to use any information in this document.

CUSTOMER DRAWING

REVISIONS				
SYM	ECN	DESCRIPTION	DATE	APPROVED

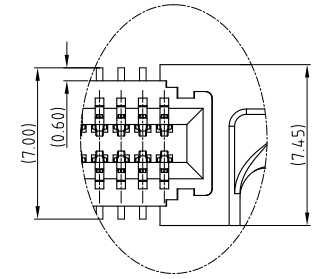
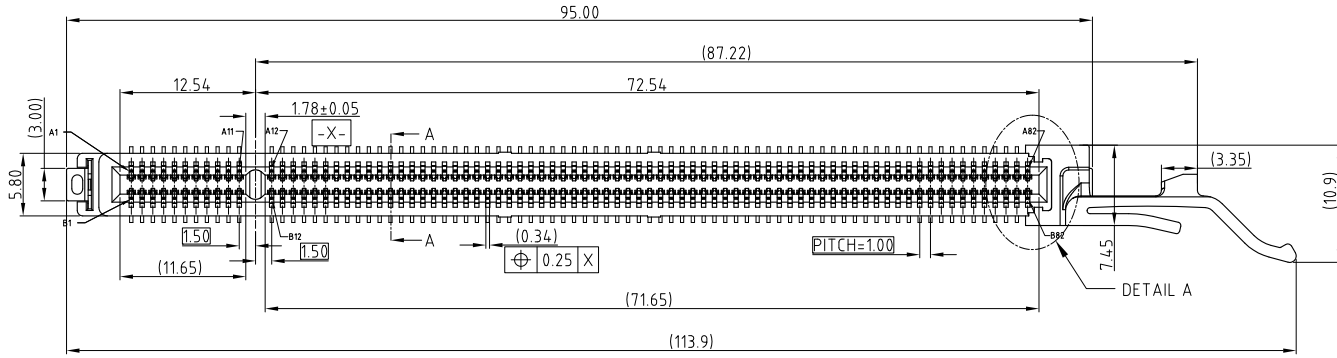

DETAIL A
SCALE 2:1
(STD TAIL)

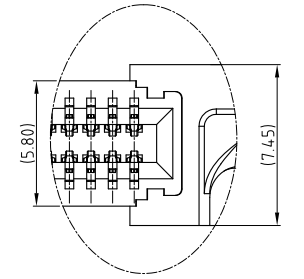

DETAIL A
SCALE 2:1
(SHORTER TAIL)

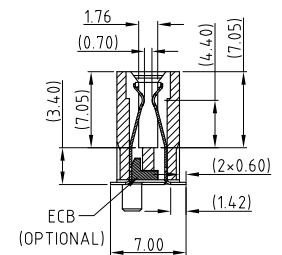
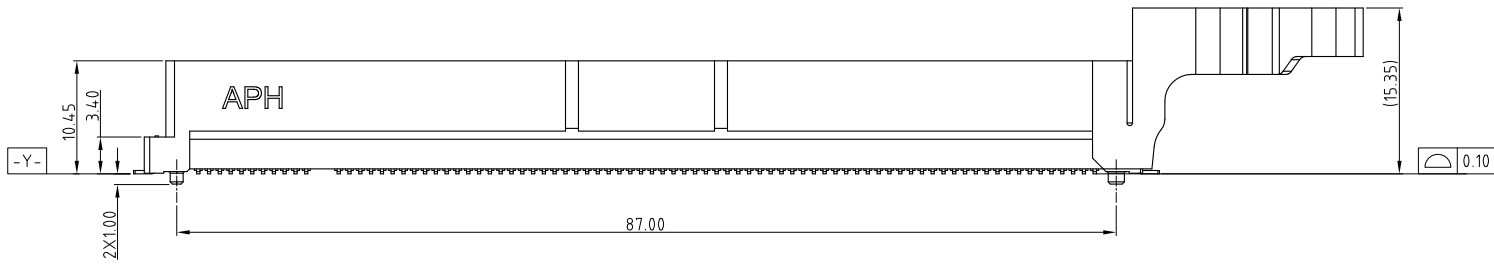

SECTION A-A
(STD TAIL)

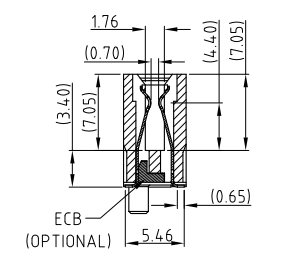

SECTION A-A
(SHORTER TAIL)

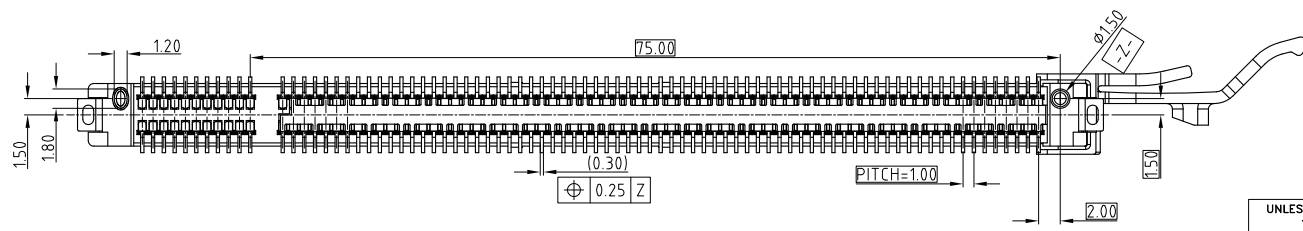

UNLESS OTHERWISE SPECIFIED TOLERANCES

	U.S.	METRIC
.X	+/-	0.25
.XX	+/-	0.20
.XXX	+/-	0.15
FRACTIONS	+/-	5'
ANGLES	+/-	5'

FOR MATERIALS AND FINISHES SEE NOTES

REMOVE SHARP EDGES	ANGLE OF PROJECTION
DIMENSIONS	
—U.S.—	INCHES
(METRIC)	(mm)

APPROVAL	DATE
DRAWN Jun.Fan	Dec.22,2020
CHECKED	
APPROVED	
DRAWING FILE :	
INTERNAL_DRAWING_CEE_C_CEE0164X1140XXX	

Amphenol		
TITLE Cool Edge Connector		
1.0mm pitch;PCle X16;32&16G		
SIZE	DRAWING NO.	REV.
A3	C CEE0164X1140XXX	6
SCALE	NONE	SHEET 2 OF 5

This document is the property of Amphenol Corporation and is delivered on the express condition that it is not to be disclosed, reproduced or used, in whole or in part, for manufacture or sale by anyone other than Amphenol Corporation without its prior consent, & that no right is granted to disclose or to use any information in this document.

CUSTOMER DRAWING

REVISIONS				
SYM	ECN	DESCRIPTION	DATE	APPROVED

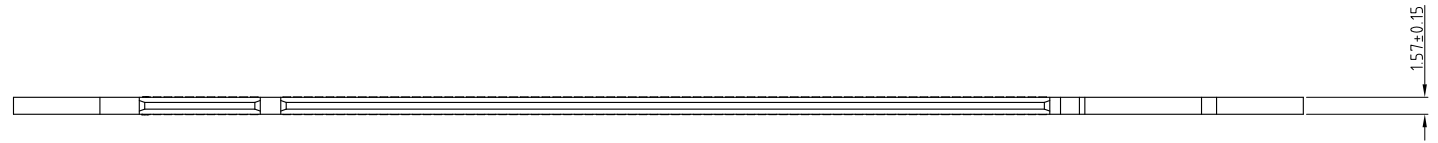
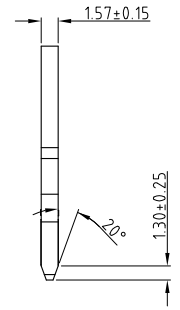
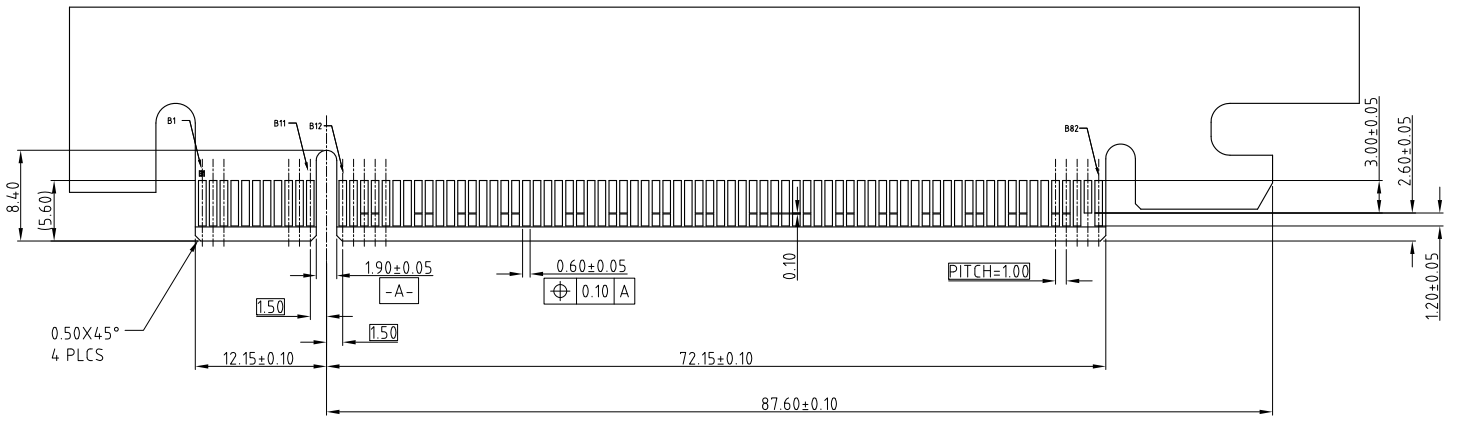

NOTE 8:
GND PIN DEFINITION

SIDE A GND PIN	A12,A15,A18,A20,A23,A24,A27,A28,A31,A34,A37, A38,A41,A42,A45,A46,A49,A51,A54,A55,A58,A59, A62,A63,A66,A67,A70,A71,A74,A75,A78,A79,A82
SIDE B GND PIN	B13,B16,B18,B21,B22,B25,B26,B29,B32,B35,B36,B39, B40,B43,B44,B47,B49,B52,B53,B56,B57,B60,B61,B64, B65,B68,B69,B72,B73,B76,B77,B80

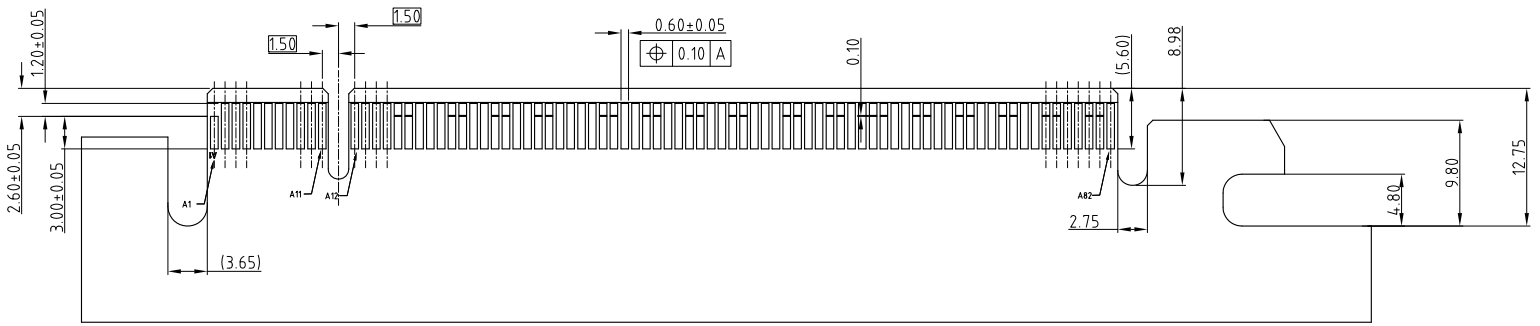

RECOMMENDED LAY OUT FOR MATING CARD, THICKNESS=1.57mm
GENERAL TOLERANCE ±0.05



UNLESS OTHERWISE SPECIFIED TOLERANCES	
U.S.	METRIC
.X +/-	0.10
.XX +/-	0.05
.XXX +/-	0.03
FRACTIONS +/-	0.03
ANGLES +/-	5°

APPROVAL		DATE
DRAWN	Jun.Fan	Dec.22,2020
CHECKED		
APPROVED		
DRAWING FILE :		
INTERNAL_DRAWING\CEV_C_CEE0164X1140XXX		
REMOVE SHARP EDGES		
DIMENSIONS		
—U.S.—	INCHES	
(METRIC)	(mm)	
ANGLE OF PROJECTION		

Amphenol		
TITLE Cool Edge Connector		
1.0mm pitch; PCIe X16; 32&16G		
SIZE	DRAWING NO.	REV.
A3	C CEE0164X1140XXX	6
SCALE	NONE	SHEET 3 OF 5

This document is the property of Amphenol Corporation and is delivered on the express condition that it is not to be disclosed, reproduced or used, in whole or in part, for manufacture or sale by anyone other than Amphenol Corporation without its prior consent, & that no right is granted to disclose or to use any information in this document.

CUSTOMER DRAWING

REVISIONS				
SYM	ECN	DESCRIPTION	DATE	APPROVED

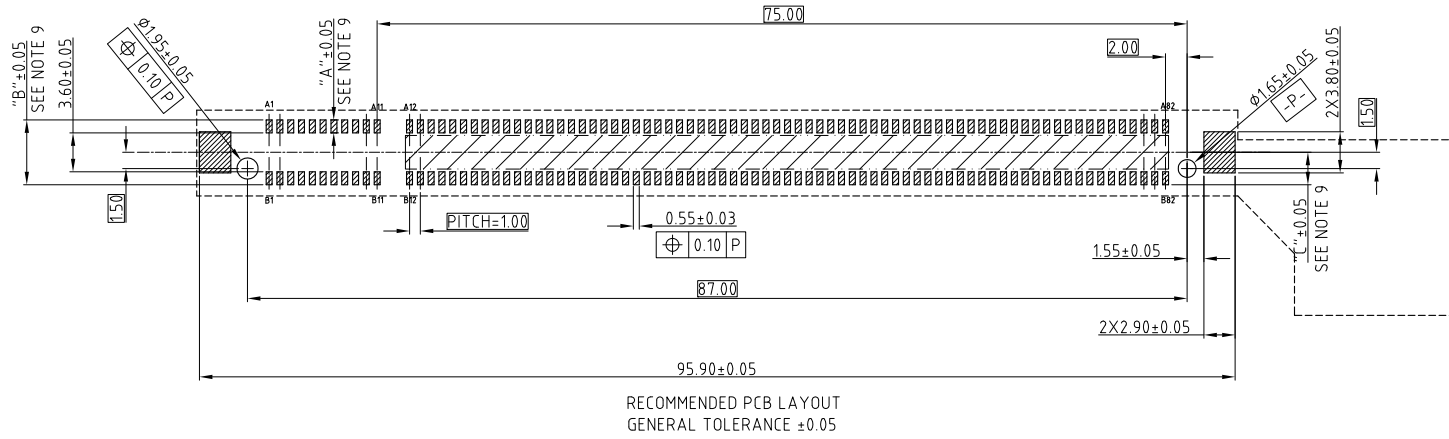

NOTE 9:
RECOMMENDED PCB DIMENSION FOR DIFFERENT SOLDER TAIL

	A	B	C	D
SHORTER TAIL	1.20	6.00	3.00	6.55
STD TAIL	1.90	7.40	3.70	7.95

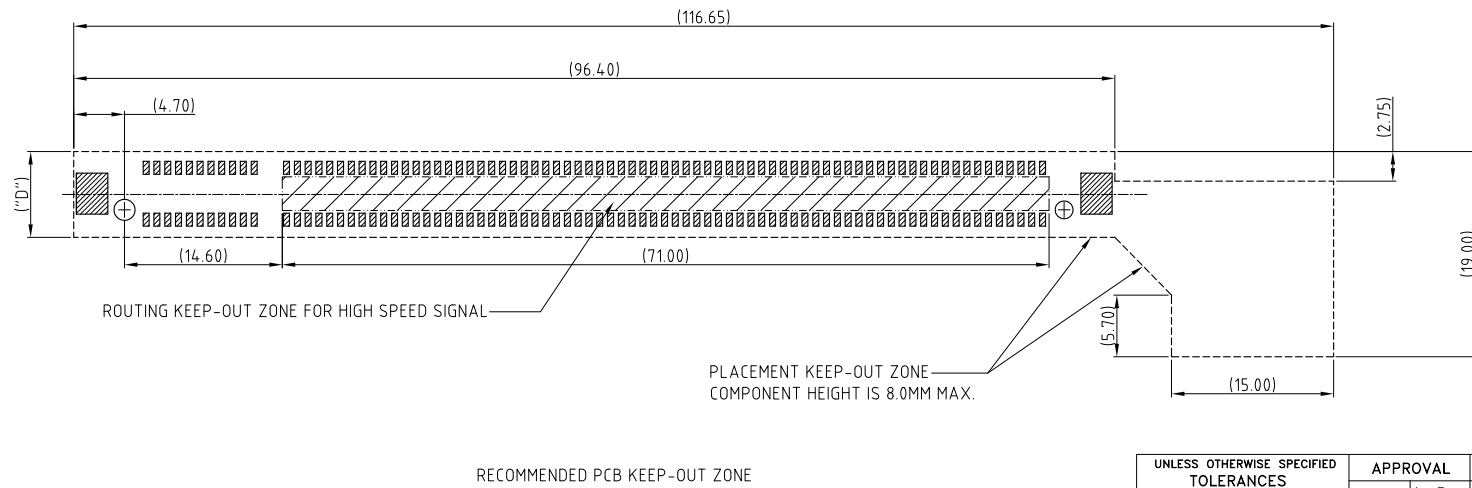

UNLESS OTHERWISE SPECIFIED TOLERANCES

	U.S.	METRIC
X	+/-	0.10
.XX	+/-	0.05
.XXX	+/-	0.03
FRACTIONS	+/-	
ANGLES	+/-	5°

FOR MATERIALS AND FINISHES SEE NOTES

REMOVE SHARP EDGES	ANGLE OF PROJECTION
DIMENSIONS	
—U.S.—	INCHES
(METRIC)	(mm)

APPROVAL	DATE
DRAWN Jun.Fan	Dec.22,2020
CHECKED	
APPROVED	
DRAWING FILE :	
INTERNAL_DRAWING\CEV_C_CEE0164X1140XXX	

Amphenol		
TITLE Cool Edge Connector		
1.0mm pitch;PCle X16;32&16G		
SIZE	DRAWING NO.	REV.
A3	C CEE0164X1140XXX	6
SCALE	NONE	SHEET 4 OF 5



This document is the property of Amphenol Corporation and is delivered on the express condition that it is not to be disclosed, reproduced or used, in whole or in part, for manufacture or sale by anyone other than Amphenol Corporation without its prior consent, & that no right is granted to disclose or to use any information in this document.

CUSTOMER DRAWING

REVISIONS				
SYM	ECN	DESCRIPTION	DATE	APPROVED

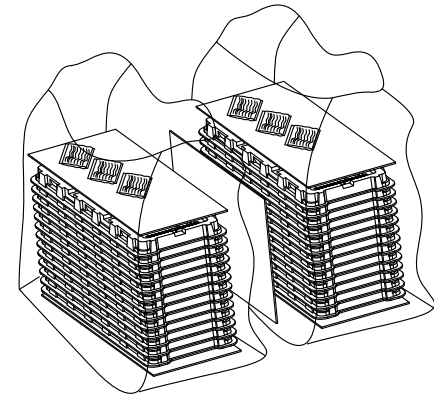
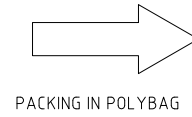
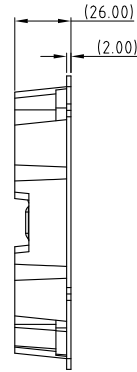
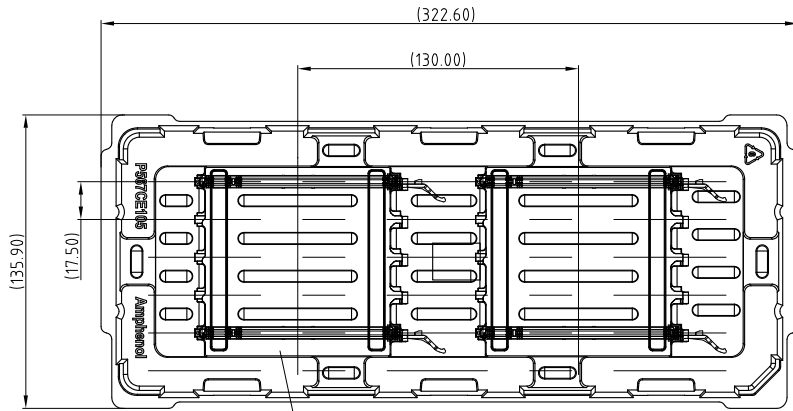

PUT INTO CARTON

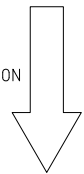

NOTE:

1. TRAY MATERIAL:
ANTI-STATIC PS ,BLACK,T=2.00±0.05MM
2. PACKING TRAY SIZE (L×W) :322.6×135.9MM
3. PACKING QTY: 10PCS / TRAY
160PCS / CARTON

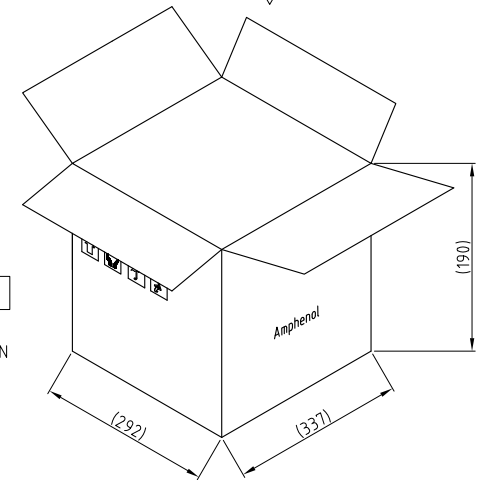
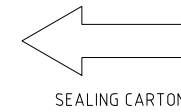
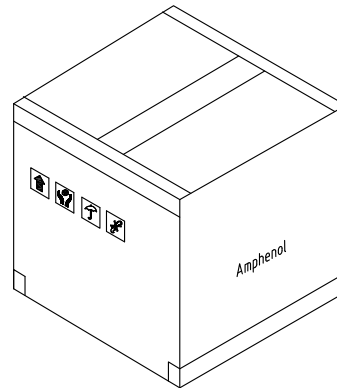

PACKING TRAY
0 322.6×135.9MM;T2.0MM



UNLESS OTHERWISE SPECIFIED TOLERANCES	
U.S.	METRIC
.X +/-	3.0
.XX +/-	2.0
.XXX +/-	/
FRACTIONS +/-	/
ANGLES +/-	5°
FOR MATERIALS AND FINISHES SEE NOTES	
REMOVE SHARP EDGES	
DIMENSIONS	
—U.S.—	INCHES
(METRIC)	(mm)

APPROVAL	DATE
DRAWN Jun.Fan	Dec.22,2020
CHECKED	
APPROVED	
DRAWING FILE :	
INTERNAL_DRAWING\CEV_C_CEE0164X1140XXX	
ANGLE OF PROJECTION	

Amphenol		
TITLE Cool Edge Connector		
1.0mm pitch;PCIe X16;32&16G		
SIZE	DRAWING NO.	REV.
A3	C CEE0164X1140XXX	6
SCALE	NONE	SHEET 5 OF 5