



Embedded Storage

**FerriSSD<sup>®</sup> Module**

**SATA Solid-State Drive Bx Series**

**Datasheet**

(Simplified Edition)

**Revision 1.7**

**Dec 2018**

## Document Confidentiality Statement

The information contained in these documents is confidential, privileged and only for the information of the intended recipient and should not be disclosed to any other person. It may not be used, published or redistributed in whole, or in part, nor many any of the information contained therein be disclosed without the prior written consent of Silicon Motion, Inc. and its affiliates (collectively "SMI").

The recipient hereby agrees that reading of this datasheet is strictly limited to her/him as authorized by SMI. If any statement, notice, requirement and/or disclaimer set forth hereunder is unacceptable, the recipient shall return this document to SMI's contact window without any delay or it is deemed to be agreed and accepted by the recipient and her/his representing companies, incorporations, or any legal entity of these statements, notices, requirements and/or disclaimers.

## IMPORTANT NOTICE

INFORMATION IN THIS DOCUMENT IS PROVIDED IN CONNECTION WITH PRODUCTS OF SILICON MOTION, INC. AND ITS AFFILIATES (COLLECTIVELY "SMI"). ALL PRODUCT, PRODUCT SPECIFICATIONS AND DATA ARE SUBJECT TO CHANGE WITHOUT NOTICE TO IMPROVE RELIABILITY, FUNCTION OR DESIGN OR OTHERWISE. NO LICENSE, EXPRESS OR IMPLIED, BY ESTOPPEL OR OTHERWISE, TO ANY INTELLECTUAL PROPERTY RIGHTS IS GRANTED BY THIS DOCUMENT. EXCEPT AS PROVIDED IN SMI'S TERMS AND CONDITIONS OF SALE FOR SUCH PRODUCTS, SMI ASSUMES NO LIABILITY WHATSOEVER, AND SMI DISCLAIMS ANY EXPRESS OR IMPLIED WARRANTY, RELATING TO SALE AND/OR USE OF SMI PRODUCTS INCLUDING LIABILITY OR WARRANTIES FOR FITNESS FOR A PARTICULAR PURPOSE, MERCHANTABILITY, OR INFRINGEMENT OF ANY PATENT, COPYRIGHT OR OTHER INTELLECTUAL PROPERTY RIGHT.

SMI, its agents, and employees, and all persons acting on its or their behalf, disclaim any and all liability for any errors, inaccuracies or incompleteness contained in any datasheet or in any other disclosure relating to any product.

Statements regarding the suitability of products for certain types of applications are based on SMI's knowledge of typical requirements that are often placed on SMI's products in generic applications. Such statements are not binding statements about the suitability of products for a particular application. It is customer's responsibility to validate that a particular product with the properties described in the product specification and/or datasheet is suitable for use in a particular application.

SMI products are not intended for use in medical, life saving, life sustaining, critical control or safety systems, or in nuclear facility applications. SMI may make changes to specifications and product descriptions at any time, without notice. SMI may have patents or pending patent applications, trademarks, copyrights, or other intellectual property rights that relate to the presented subject matter. The furnishing of documents and other materials and information does not constitute any license, express or implied, by estoppel or otherwise, to any such patents, trademarks, copyrights, or other intellectual property rights. The information in this document is furnished for informational use only, is subject to change without notice, and should not be construed as a commitment by SMI. SMI assumes no responsibility or liability for any errors or inaccuracies that may appear in this document or any software that may be provided in association with this document. Except as permitted by the permitted use abovementioned, no part of this document may be reproduced, stored in a retrieval system, or transmitted in any form or by any means without the express written consent of SMI. Contact your local SMI sales office or your distributor to obtain the latest specifications and before placing your product order.

Silicon Motion and Silicon Motion logo are registered trademarks of SMI and/or its affiliates. Other brand names mentioned herein are for identification purposes only and may be trademarks and/or registered trademarks of their respective owners.

**Revision History**

Revision	Date	Description
0.1	Mar 21, 2012	Initial release
1.0	Sep 17, 2012	Official release <ul style="list-style-type: none"> <li>• Updated the FerriSSD trademark logo, document title, and a few descriptions (1)</li> <li>• Updated non-operating and storage temperature (1.2) (5.1)</li> <li>• Added performance values</li> <li>• Updated and added commands, SMART data, and ID table (4)</li> <li>• Updated reliability data (6)</li> <li>• Updated product coding rule (7)</li> </ul>
1.1	Nov 14, 2012	Removed the wet bulb parameter from Table 12 (5.2)
1.2	Jul 31, 2013	<ul style="list-style-type: none"> <li>• Added FerriSSD Module BB Series</li> <li>• Updated SATA interface rate support and added trim command support(1.2)</li> <li>• Updated FerriSSD M297 mechanical drawing (3.2)</li> <li>• Updated FerriSSD M297 pin assignments/functions: P1, P2, P3 (3.2.1)</li> <li>• Updated FerriSSD M300 pin assignments/functions: P42, P43, P44 (3.3.2)</li> <li>• Updated part number and product coding rule (7)</li> <li>• Moved 3.1 Supply Voltage to (2.2)</li> <li>• Removed FerriSSD M25 and Error Rate definition (1.2) (3) (7.1)</li> <li>• Updated and added commands in the Comment Set Table and the note</li> <li>• Updated the ID table (Table 3) and added the notes: word 77-79, 100-103, 162, 163, 169, 222, and 255 (4.2)</li> <li>• Minor description update of Life Expectancy (6.2)</li> </ul>
1.3	Jul 31, 2014	<ul style="list-style-type: none"> <li>• Added FerriSSD M25 (1.2) (2.2) (3.1) (7.1)</li> <li>• Fixed typo of Command Set: RUF Feature Set (4.1)</li> <li>• Fixed typo of Identify Device Data: Word 218-221 (4.2)</li> <li>• Updated the reliability data (6.1) (6.2)</li> </ul>
1.4	Oct 24, 2014	<ul style="list-style-type: none"> <li>• Added FerriSSD Module BC series</li> <li>• Updated XtendFerri P/E cycle (6.2)</li> <li>• Updated the Identify Device Data : word 2, word 4 and word 5 (Table 3)</li> </ul>
1.5	Feb 13, 2015	<ul style="list-style-type: none"> <li>• Added BD series</li> <li>• Added FerriSSD M.2 form factor (1.2) (2.2) (3.4) (7.1)</li> <li>• Removed the system performance values (2.4)</li> <li>• Updated the dimensions and mechanical drawings of FerriSSD M25, M297, and M300 form factors (3.1.1) (3.2.1) (3.3.1)</li> </ul>
1.6	Jan 15, 2018	<ul style="list-style-type: none"> <li>• Updated product descriptions and key features (1.1) (1.2)</li> <li>• Added FerriSSD DOM and correspondent specifications (2.2) (3.5) (7.1)</li> </ul>
1.7	Dec 26, 2018	<ul style="list-style-type: none"> <li>• Released the simplified edition</li> <li>• Fixed the function definitions of pin S5 and S6 in FerriSSD M25, M297, and DOM (3.1.2) (3.2.2) (3.5.2)</li> </ul>

## Table of Contents

<b>1. Overview .....</b>	<b>5</b>
1.1 Product Description .....	5
1.2 Key Features .....	5
1.3 Block Diagram .....	7
<b>2. Product Specifications .....</b>	<b>8</b>
2.1 Host Interface .....	8
2.2 Supply Voltage .....	8
<b>3. Physical Specifications .....</b>	<b>9</b>
3.1 FerriSSD M25 (2.5") .....	9
3.1.1 FerriSSD M25 Mechanical Drawing .....	9
3.1.2 FerriSSD M25 Pin Assignments .....	10
3.2 FerriSSD M297 (Slim Lite) .....	11
3.2.1 FerriSSD M297 Mechanical Drawing .....	11
3.2.2 FerriSSD M297 Pin Assignments .....	12
3.3 FerriSSD M300 (mSATA) .....	13
3.3.1 FerriSSD M300 Mechanical Drawing .....	13
3.3.2 FerriSSD M300 Pin Assignments .....	15
3.4 FerriSSD M.2 .....	17
3.4.1 FerriSSD M.2 Mechanical Drawing .....	17
3.4.2 FerriSSD M.2 Pin Assignments .....	19
3.5 FerriSSD SATA DOM .....	22
3.5.1 FerriSSD DOM Mechanical Drawing .....	22
3.5.2 FerriSSD DOM Pin Assignments .....	23
<b>4. Command Sets .....</b>	<b>24</b>
4.1 Command Set .....	24
4.2 Identify Device Data .....	26
<b>5. Environmental Conditions .....</b>	<b>29</b>
5.1 Temperature .....	29
5.2 Humidity .....	29
5.3 RoHS .....	29
<b>6. Reliability .....</b>	<b>30</b>
6.1 Reliability Specifications .....	30
6.2 Endurance .....	30
6.3 Preventive Maintenance .....	30
<b>7. Ordering Information .....</b>	<b>31</b>
7.1 Product Coding Rule .....	31

# 1. Overview

## 1.1 Product Description

---

Silicon Motion leverages the industry leading technologies and experiences introduce the fully integrated FerriSSD® module in small and light form factors for consumer applications such as tablets, navigation, thin-client, as well as a variety of embedded applications.

The FerriSSD is designed optimally for a wide range of embedded applications that behaves like a SATA hard drive featuring fast access time and enhanced endurance. Without any moving mechanical parts, The FerriSSD provides a shock-protected and quiet-operating environment for mobile storage requirements. The combinations of Silicon Motion advanced technologies such as error correction, bad block management, and IntelligentScan™ monitoring application enable FerriSSD DataRefresh™ to deliver the most robust data integrity and protection in SSD storage.

With high reliability, industry-leading performance and programmable firmware, the FerriSSD is the ultimate non-volatile storage solution for today's fast-moving consumer electronics as well as industrial level applications. The FerriSSD module is available in various form factors and densities for different storage needs.

## 1.2 Key Features

---

- Host Interface
  - Industrial Standard SATA1.5Gbps / 3.0Gbps interface rate
  - SATA Device Sleep (DevSleep) and Partial/Slumber power saving modes supported
  - Supports trim command with indeterminate pattern <sup>1</sup>
- High Capacity
  - Supports unformatted capacity up to 64GB
- Small Form Factor
  - FerriSSD M25: 2.5" case
  - FerriSSD M297: Slim Lite (MO-297)
  - FerriSSD M300: mSATA (MO-300A)
  - FerriSSD M.2: M.2 SSD (type 2242)
  - FerriSSD DOM: SATA DOM (Disk On Module)
- Easy-to-Use
  - The Plug & Play device only requires format/fdisk prior to use
- Enhanced Data Reliability
  - Advanced Hardware BCH Error Correcting Code (ECC) Engine
  - StaticDataRefresh and EarlyRetirement technologies ensure the data reliability

---

<sup>1</sup> The trim command is an option.

- Robust Data Protection
  - Advanced system level protection against unstable power supply
  - Multiple data security zones
  - PowerShield and DataPhoenix technologies support power-down data protection and recovery
- SSD Status Monitoring
  - Supports Self-Monitoring, Analysis, and Reporting Technology (S.M.A.R.T.) commands
- Advanced Global Wear Leveling
  - Fully utilizes all memory blocks across management units/die(s)
  - Maximizes the SSD lifespan with low Write Amplification Index (WAI)
- Advanced Security
  - Supports ATA8 security feature set
  - Supports real time Full Disk Encryption (FDE) with Advanced Encryption Standard (AES) 128/256-bit strength<sup>2</sup>
  - Supports hardware SHA-256 and True Random Number Generator (TRNG)<sup>2</sup>
- Power Supply: 5V/3.3V<sup>3</sup>
- Temperature Range
  - Operating Temperature - Commercial : 0°C ~ 70°C
  - Operating Temperature - Industrial: -40°C ~ +85°C
  - Non-Operating and Storage Temperature: -55°C ~ +85°C

---

<sup>2</sup> The encryption function is an option. Refer to 7.1 product coding rule and FerriSSD selection guide for details.

<sup>3</sup> 5V applies to FerriSSD M25, FerriSSD M297 and FerriSSD DOM; 3.3V applies to FerriSSD M300 and FerriSSD M.2.

### 1.3 Block Diagram

Figure 1: FerriSSD Block Diagram

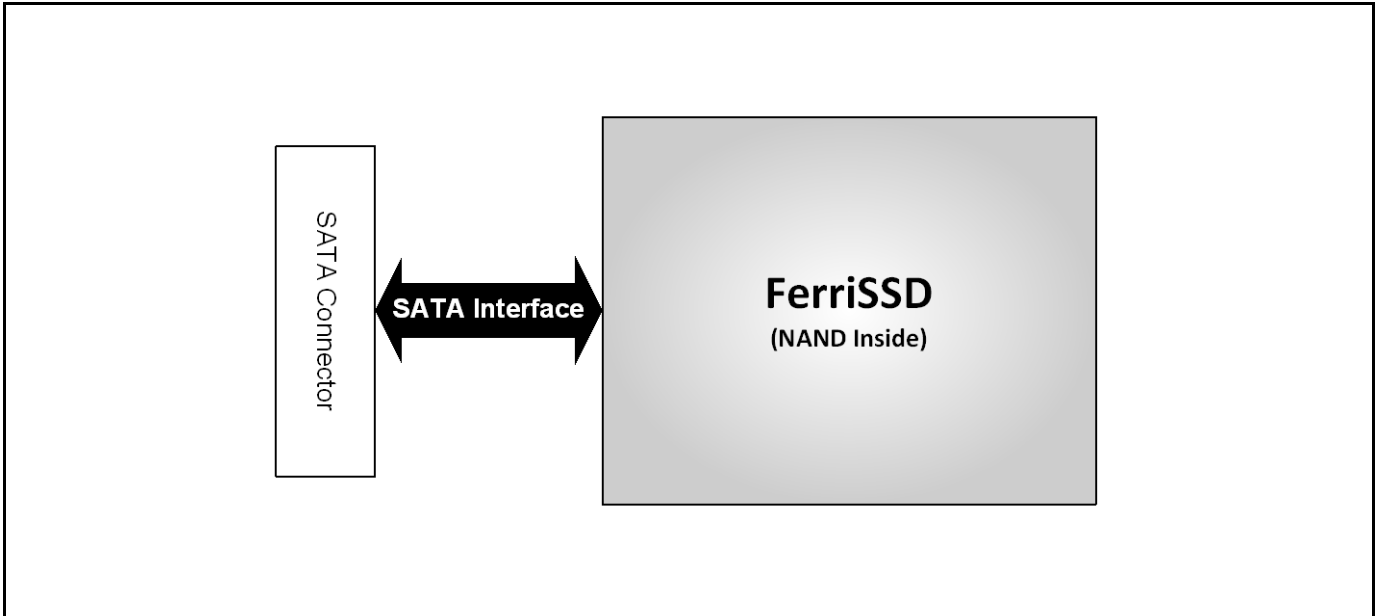

## 2. Product Specifications

### 2.1 Host Interface

---

The FerriSSD complies to the following industrial standards:

- Serial ATA Revision 2.6
- SATA 1.5/3.0Gbps interface rate
- ATA/ATAPI-8

### 2.2 Supply Voltage

---

**Table 1: FerriSSD Module Supply Voltage**

Model	Min	Typ	Max	Unit
FerriSSD M25	4.5	5	5.5	V
FerriSSD M297	4.5	5	5.5	V
FerriSSD M300	3	3.3	3.6	V
FerriSSD M.2	3.135	3.3	3.465	V
FerriSSD DOM	4.5	5	5.5	V



### 3. Physical Specifications

#### 3.1 FerriSSD M25 (2.5")

##### 3.1.1 FerriSSD M25 Mechanical Drawing

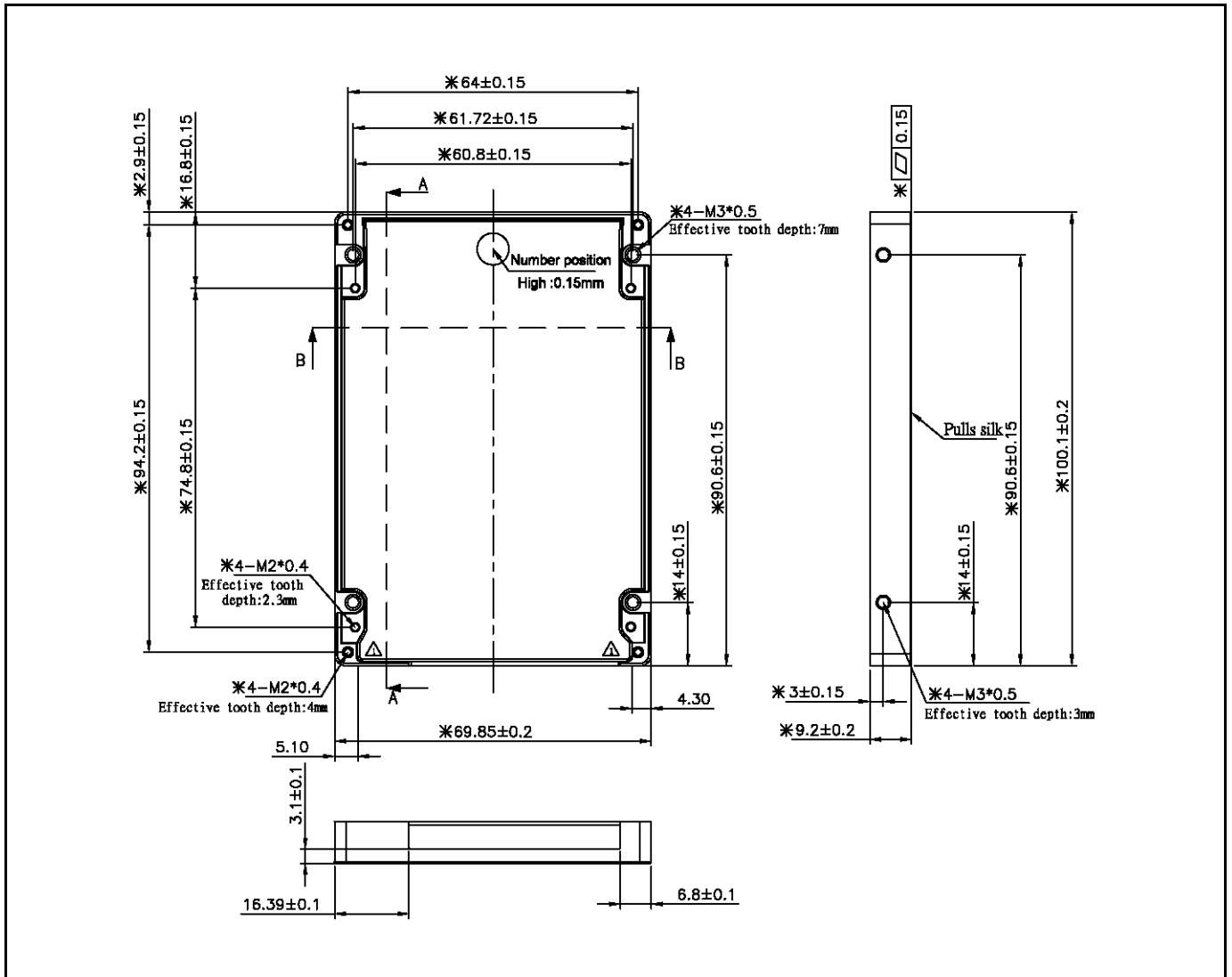

Unit: mm

**3.1.2 FerriSSD M25 Pin Assignments**

Segment	Pin	Function	Description
Signal Segment	S1	GND	
	S2	A+	RXp
	S3	A-	RXn
	S4	GND	
	S5	B-	TXn
	S6	B+	TXp
	S7	GND	
Power Segment	P1	V33	3.3V Power
	P2	V33	3.3V Power
	P3	V33	3.3V Power
	P4	GND	
	P5	GND	
	P6	GND	
	P7	5V	5V Power
	P8	5V	5V Power
	P9	5V	5V Power
	P10	GND	
	P11	DAS	Device Activity Signal
	P12	GND	
	P13	V12	12V Power
	P14	V12	12V Power
	P15	V12	12V Power

3.2 FerriSSD M297 (Slim Lite)

3.2.1 FerriSSD M297 Mechanical Drawing

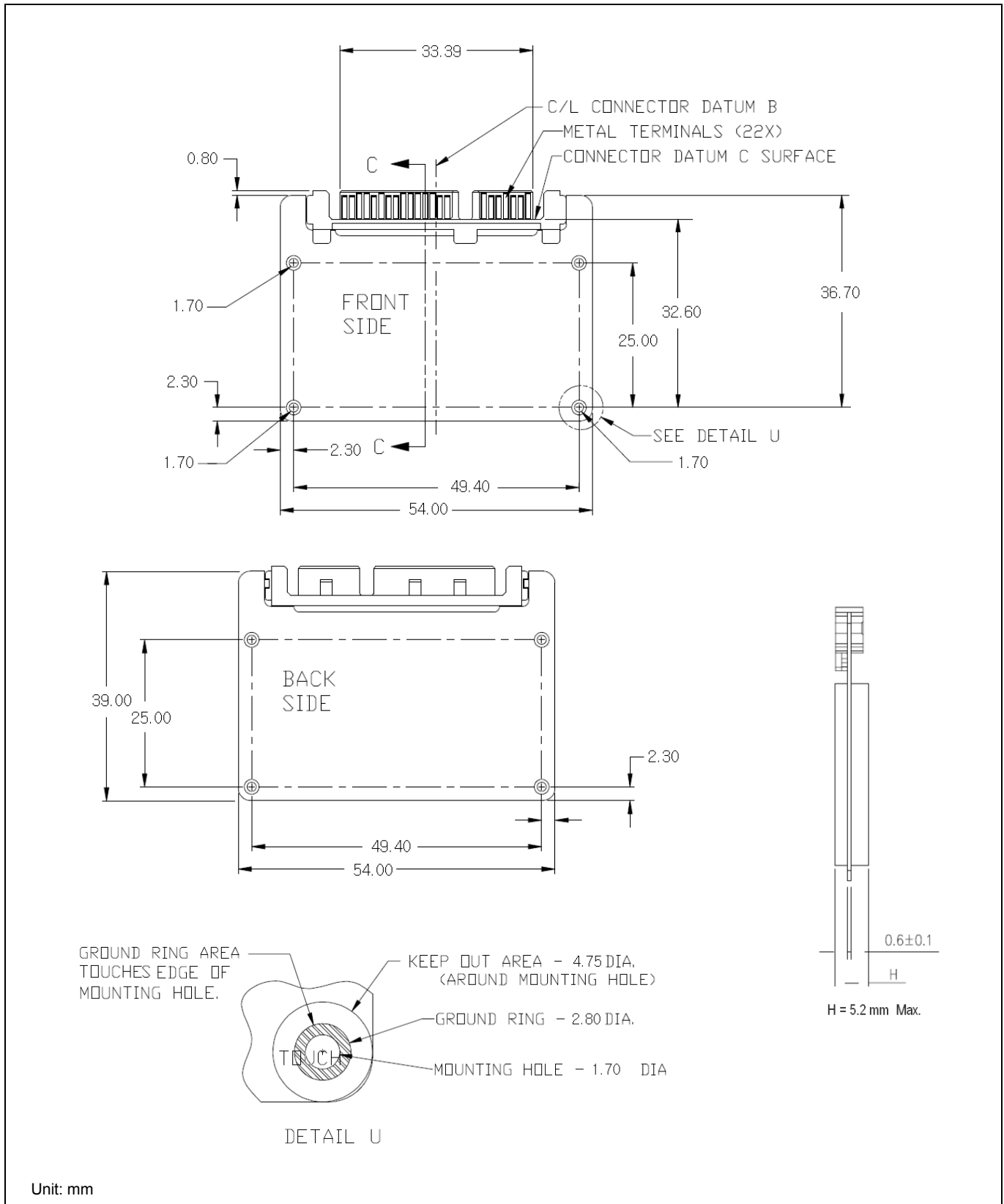

**3.2.2 FerriSSD M297 Pin Assignments**

Segment	Pin	Function	Description
Signal Segment	S1	GND	
	S2	A+	RXp
	S3	A-	RXn
	S4	GND	
	S5	B-	TXn
	S6	B+	TXp
	S7	GND	
Power Segment	P1	Retired	
	P2	Retired	
	P3	DEVSLP	SATA DEVSLP (Device Sleep) Signal
	P4	GND	
	P5	GND	
	P6	GND	
	P7	5V	5V Power
	P8	5V	5V Power
	P9	5V	5V Power
	P10	GND	
	P11	DAS	Device Activity Signal
	P12	GND	
	P13	V12	12V Power
	P14	V12	12V Power
	P15	V12	12V Power

3.3 FerriSSD M300 (mSATA)

3.3.1 FerriSSD M300 Mechanical Drawing

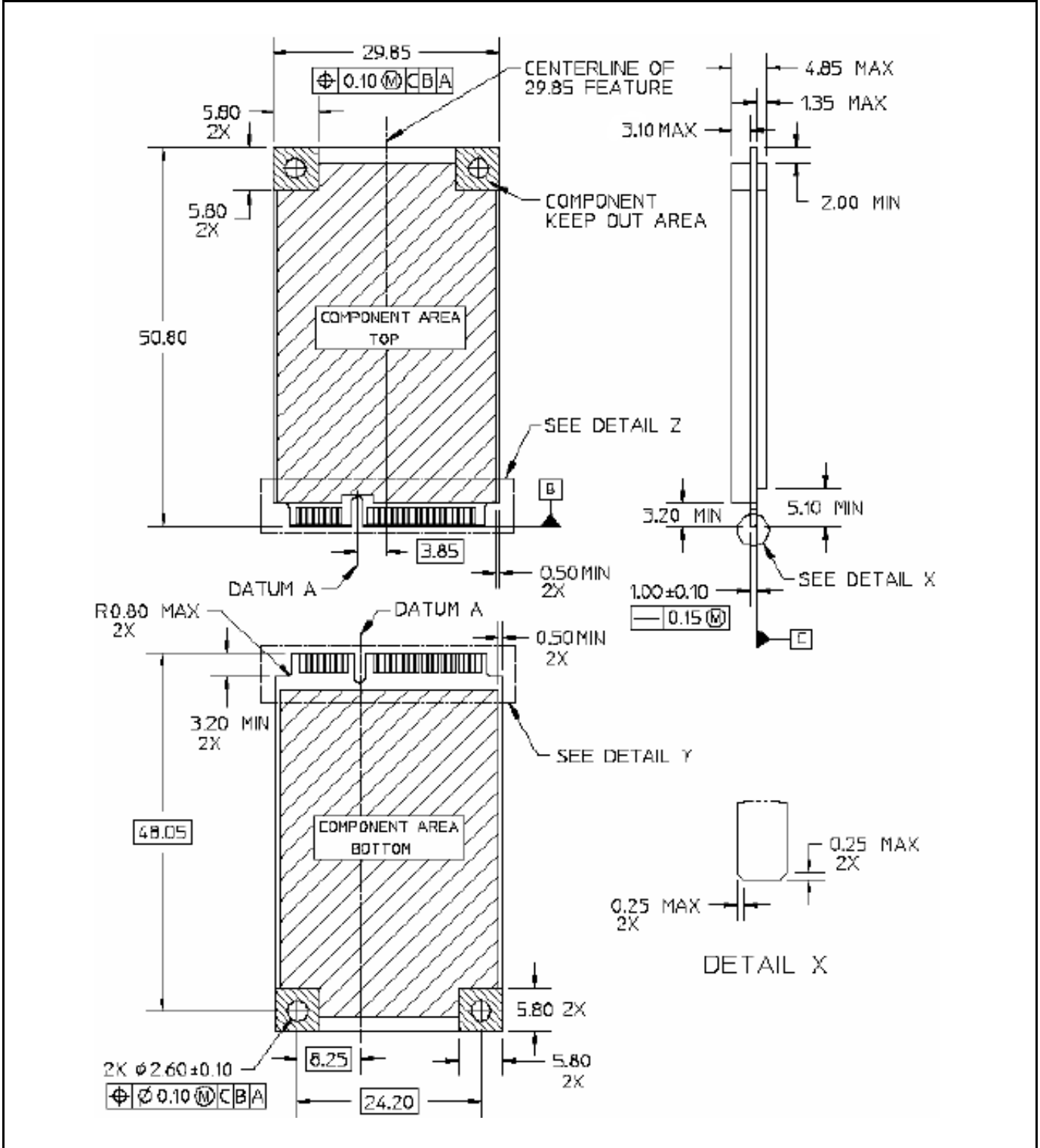

Unit: mm

Detailed Z, Y, W

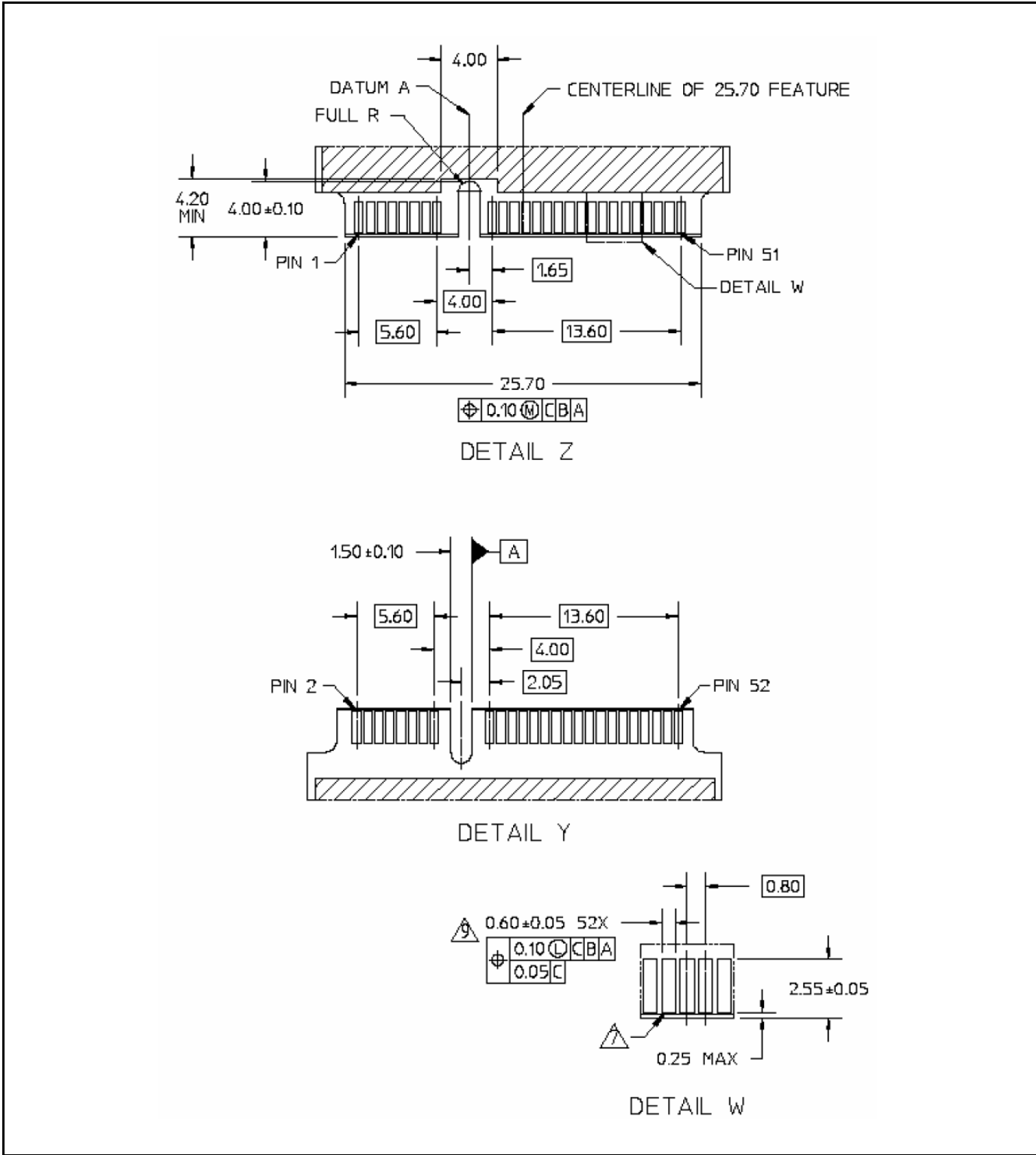

Unit: mm

**3.3.2 FerriSSD M300 Pin Assignments**

Pin	Type	Description
P1	Reserved	No Connect
P2	+3.3V	3.3V Source
P3	Reserved	No Connect
P4	GND	Return Current Path
P5	Reserved	No Connect
P6	+1.5V	1.5V Source
P7	Reserved	No Connect
P8	Reserved	No Connect
P9	GND	Return Current Path
P10	Reserved	No Connect
P11	Reserved	No Connect
P12	Reserved	No Connect
P13	Reserved	No Connect
P14	Reserved	No Connect
P15	GND	Return Current Path
P16	Reserved	No Connect
P17	Reserved	No Connect
P18	GND	Return Current Path
P19	Reserved	No Connect
P20	Reserved	No Connect
P21	GND	Return Current Path
P22	Reserved	No Connect
P23	+B	Host Receiver Differential Signal Pair
P24	+3.3V	3.3V Source
P25	-B	Host Receiver Differential Signal Pair
P26	GND	Return Current Path
P27	GND	Return Current Path
P28	+1.5V	1.5V Source
P29	GND	Return Current Path
P30	Two Wire Interface	Two Wire Interface Clock Pin 30 is intended for use as a two wire interface to read a memory device to determine device information (an example of this would be for use as SMB bus pins). This pin is not designed to be active in conjunction with the SATA signal differential pairs.
P31	-A	Host Transmitter Differential Signal Pair

Pin	Type	Description
P32	Two Wire Interface	Two Wire Interface Data Pin 32 is intended for use as a two wire interface to read a memory device to determine device information (an example of this would be for use as SMB bus pins). This pin is not designed to be active in conjunction with the SATA signal differential pairs.
P33	+A	Host Transmitter Differential Signal Pair
P34	GND	Return Current Path
P35	GND	Return Current Path
P36	Reserved	No Connect
P37	GND	Return Current Path
P38	Reserved	No Connect
P39	+3.3V	3.3V Source
P40	GND	Return Current Path
P41	+3.3V	3.3V Source
P42	Reserved	No Connect
P43	Device Type	Shall be a No Connect on mSATA Devices
P44	DEVSLP	Enter/Exit DevSleep
P45	Vendor	Vendor Specific / Manufacturing Pin (No connect on the host side)
P46	Reserved	No Connect
P47	Vendor	Vendor Specific / Manufacturing Pin (No connect on the host side)
P48	+1.5V	1.5V Source
P49	DA/DSS	Device Activity Signal / Disable Staggered Spin-up
P50	GND	Return Current Path
P51	Presence Detection	Shall be pulled to GND by device (Presence detection pin provided for tamper proof functionality)
P52	+3.3V	3.3V Source



**3.4 FerriSSD M.2**

**3.4.1 FerriSSD M.2 Mechanical Drawing**

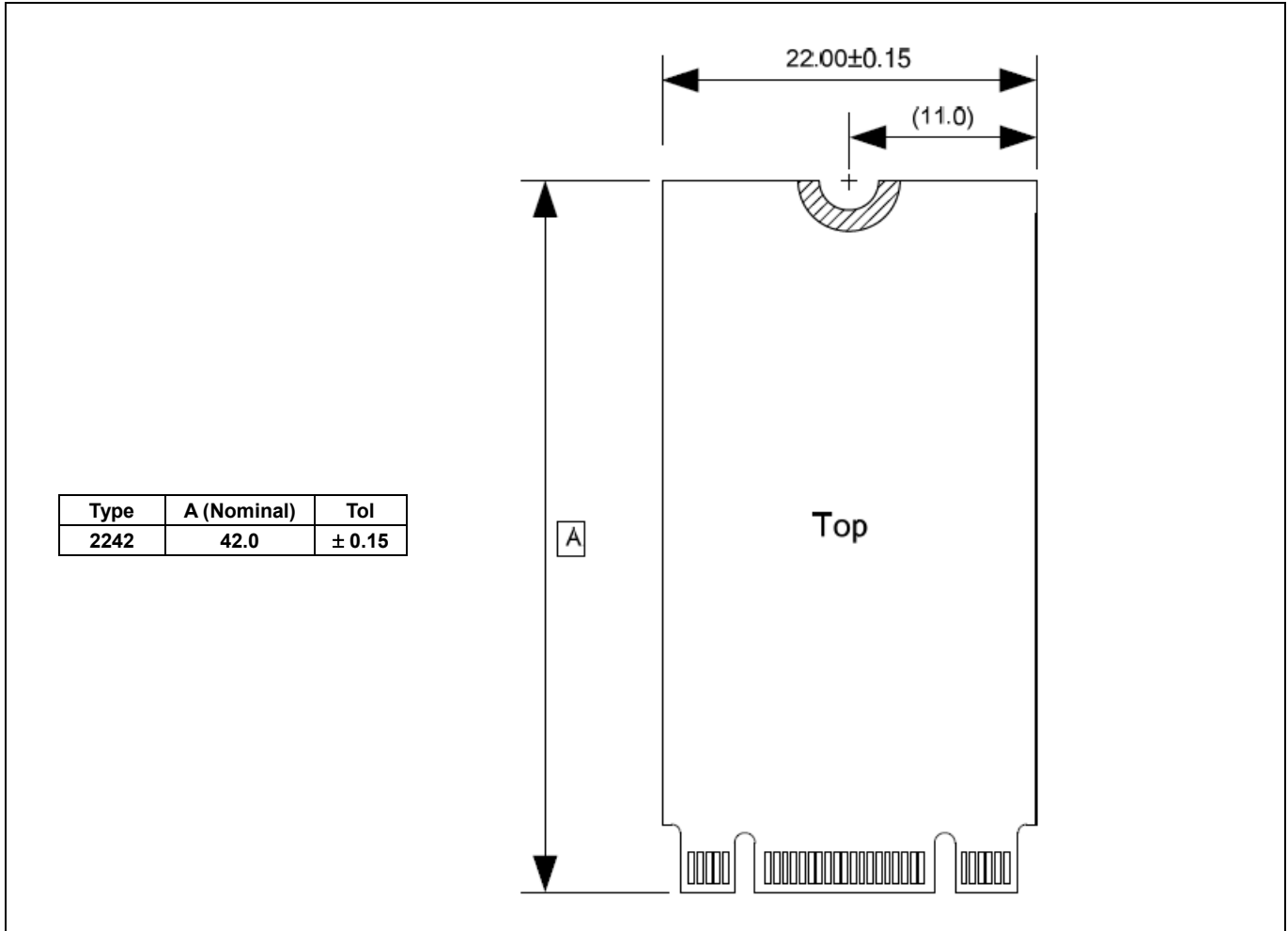

All dimensions in mm

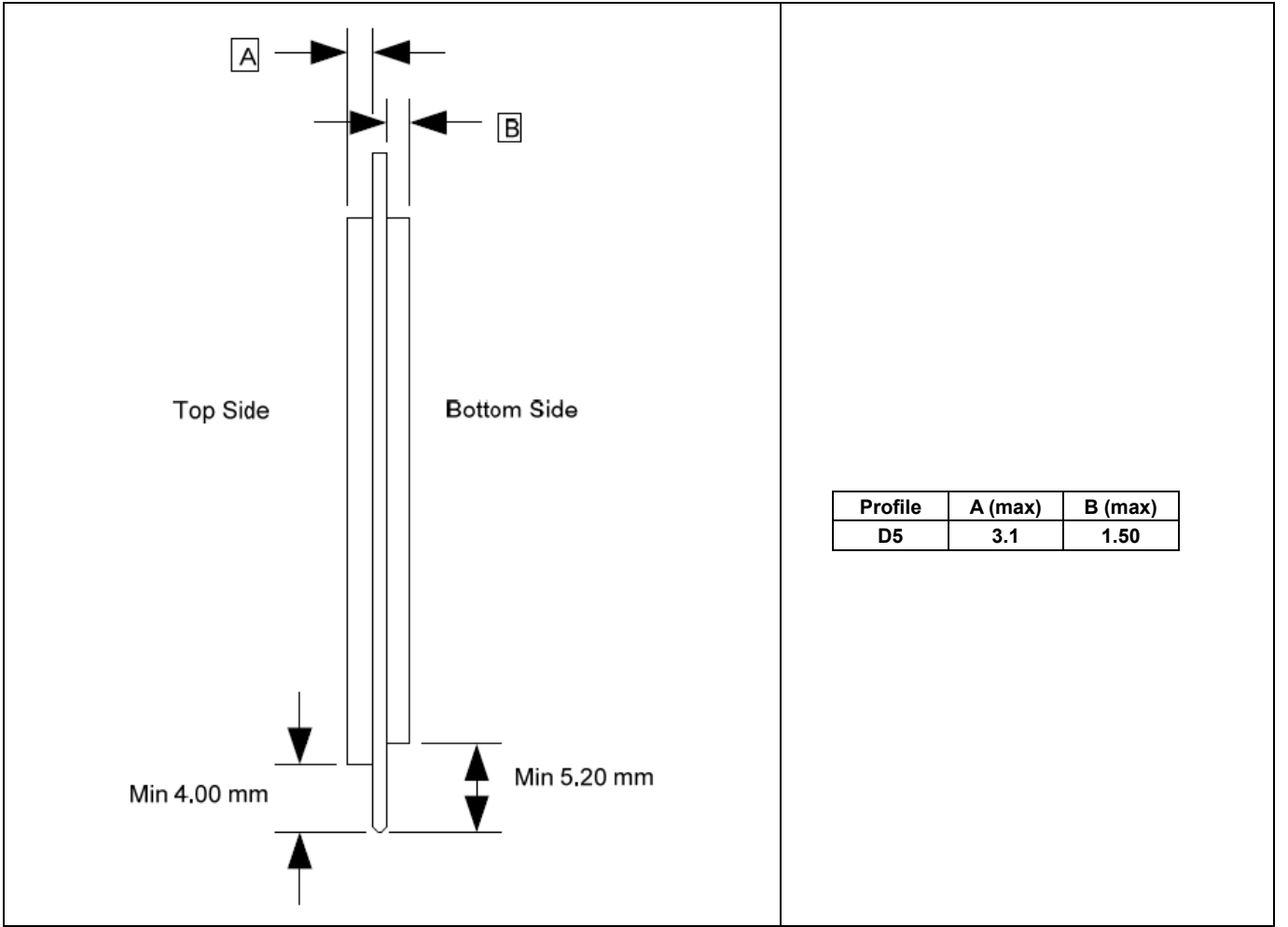

**3.4.2 FerriSSD M.2 Pin Assignments**

Pin	Type	Description
1	CONFIG_3	Shall be a No connect on SATA M.2 devices
2	3.3V	Supply pin, 3.3V
3	GND	Ground
4	3.3V	Supply pin, 3.3V
5	No connect	No connect
6	Not Available	No connect (used for other purposes)
7	Not Available	No connect (used for other purposes)
8	Not Available	No connect (used for other purposes)
9	No connect	No connect
10	DAS/DSS	Device Activity Signal / Disable Staggered Spinup
11	No connect	No connect (used for other purposes)
12	(removed for key)	Mechanical notch B
13	(removed for key)	Mechanical notch B
14	(removed for key)	Mechanical notch B
15	(removed for key)	Mechanical notch B
16	(removed for key)	Mechanical notch B
17	(removed for key)	Mechanical notch B
18	(removed for key)	Mechanical notch B
19	(removed for key)	Mechanical notch B
20	Not Available	No connect (used for other purposes)
21	CONFIG_0	Shall be a No connect on SATA M.2 devices
22	Not available	No connect (used for other purposes)
23	Not available	No connect (used for other purposes)
24	Not available	No connect (used for other purposes)
25	Not available	No connect (used for other purposes)
26	Not available	No connect (used for other purposes)
27	GND	Ground
28	Not available	No connect (used for other purposes)
29	Not available	No connect (used for other purposes)
30	Not available	No connect (used for other purposes)
31	Not available	No connect (used for other purposes)
32	Not available	No connect (used for other purposes)
33	GND	Ground
34	Not available	No connect (used for other purposes)
35	Not available	No connect (used for other purposes)

Pin	Type	Description
36	Not available	No connect (used for other purposes)
37	Not available	No connect (used for other purposes)
38	DEVSLP	Device Sleep, input. If driven high the host is informing the SSD to enter a low power state.
39	GND	Ground
40	Not available	No connect (used for other purposes)
41	SATA-B+	Host receiver differential signal pair
42	na	No connect (used for other purposes)
43	SATA-B-	Host receiver differential signal pair
44	Not available	No connect (used for other purposes)
45	GND	Ground
46	Not available	No connect (used for other purposes)
47	SATA-A-	Host transmitter differential signal pair
48	Not available	No connect (used for other purposes)
49	SATA-A+	Host transmitter differential signal pair
50	Not available	No connect (used for other purposes)
51	GND	Ground
52	Not available	No connect (used for other purposes)
53	Not available	No connect (used for other purposes)
54	Not available	No connect (used for other purposes)
55	Not available	No connect (used for other purposes)
56	MFG1	Manufacturing pin. Use determined by vendor. <sup>1</sup>
57	GND	Ground
58	MFG2	Manufacturing pin. Use determined by vendor. <sup>1</sup>
59	(removed for key)	Mechanical notch M
60	(removed for key)	Mechanical notch M
61	(removed for key)	Mechanical notch M
62	(removed for key)	Mechanical notch M
63	(removed for key)	Mechanical notch M
64	(removed for key)	Mechanical notch M
65	(removed for key)	Mechanical notch M
66	(removed for key)	Mechanical notch M
67	Not available	No connect (used for other purposes)
68	Not available	No connect (used for other purposes)
69	CONFIG_1	Shall be a No connect on SATA M.2 devices
70	3.3V	Supply pin, 3.3V

**Note**<sup>1</sup> : No connect on a host.

Pin	Type	Description
71	GND	Ground
72	3.3V	Supply pin, 3.3V
73	GND	Ground
74	3.3V	Supply pin, 3.3V
75	CONFIG_2	Shall be a No connect on SATA M.2 devices

3.5 FerriSSD SATA DOM

3.5.1 FerriSSD DOM Mechanical Drawing

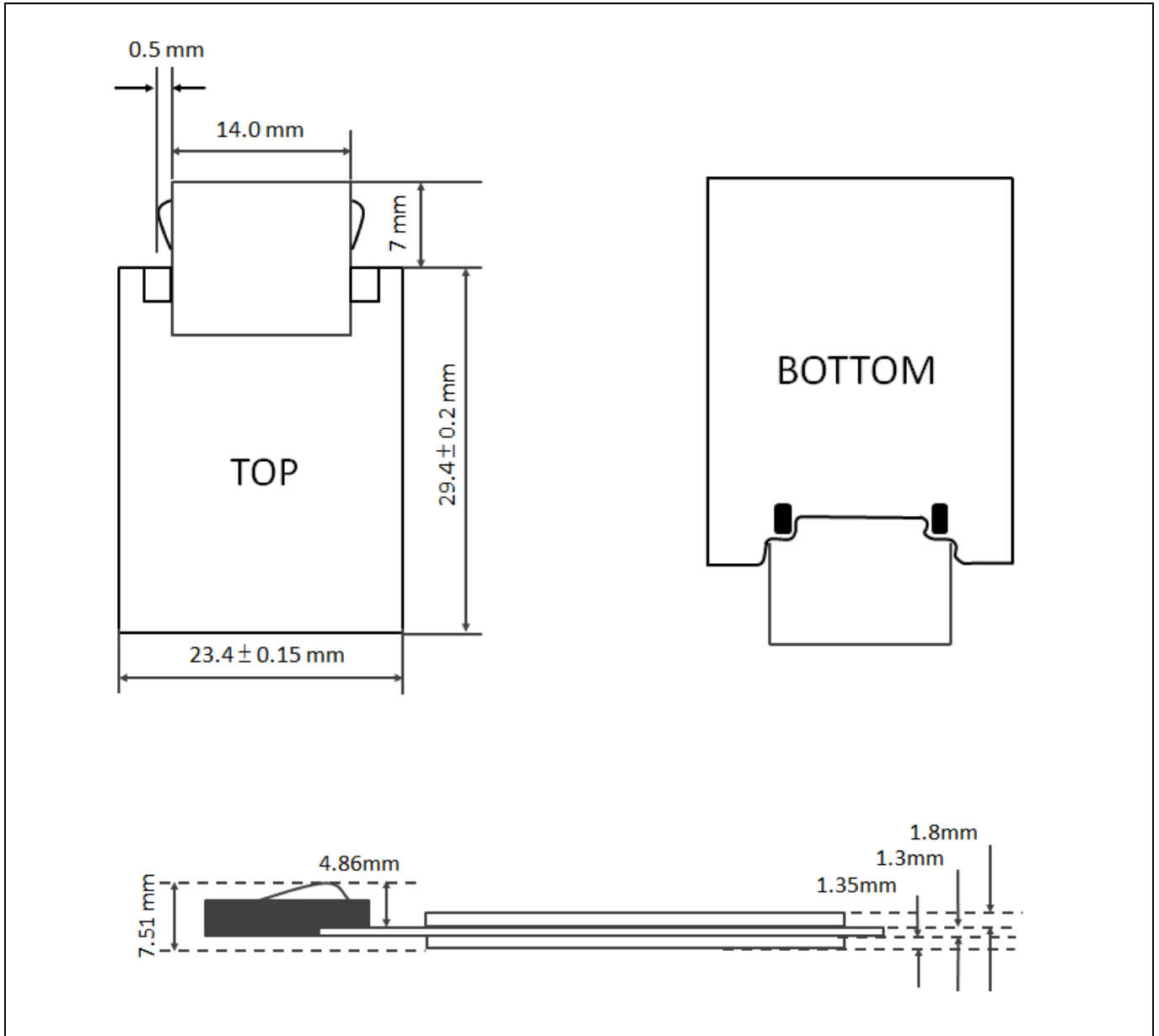

**3.5.2 FerriSSD DOM Pin Assignments**

Segment	Pin	Function	Description
Signal Segment	S1	GND	
	S2	A+	RXp
	S3	A-	RXn
	S4	GND	
	S5	B-	TXn
	S6	B+	TXp
	S7	GND	
Power Segment	P1	5V	5V Power
	P2	GND	

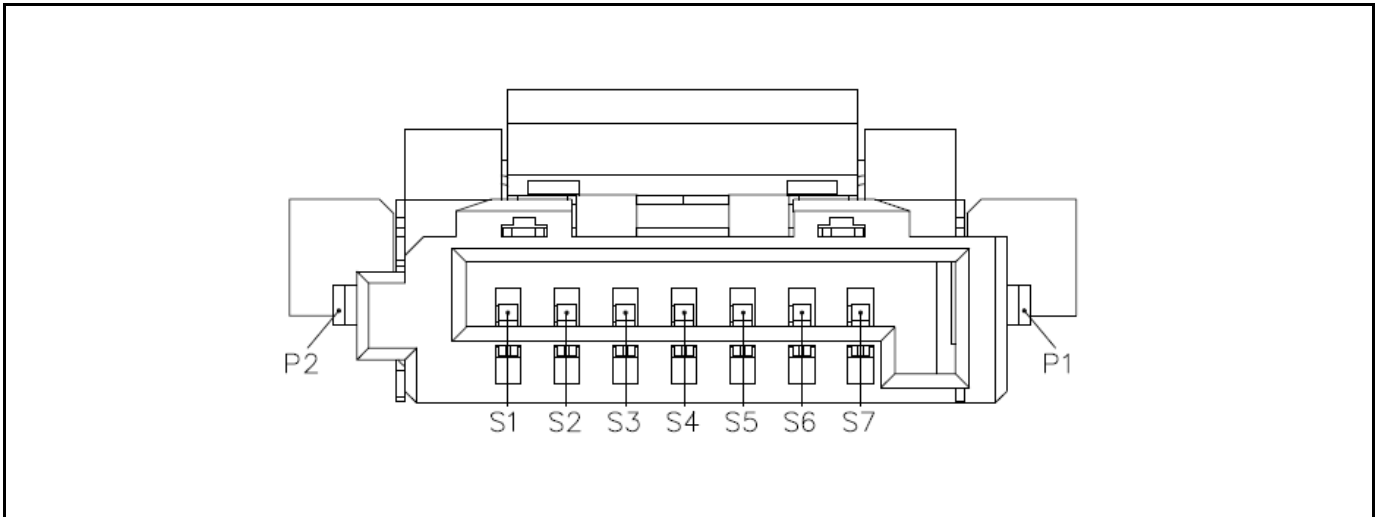
**Pin-Out on FerriSSD SATA DOM**

## 4. Command Sets

### 4.1 Command Set

**Table 2: Command Set**

Command Set	Command	Command Code	Protocol
General Feature Set	Execute Drive Diagnostic	90h	Device diagnostic
	Flush Cache	E7h	Non-data
	Identify Device	ECh	PIO data-in
	Initial Drive Parameters	91h	Non-data
	NOP	00h	Non-data
	Read Buffer	E4h	PIO data-in
	Read DMA	C8h	DMA
	Read Multiple	C4h	PIO data-in
	Read Sector(s)	20h	PIO data-in
	Read Verify Sector(s)	40h or 41h	Non-data
	Set Feature	EFh	Non-data
	Set Multiple Mode	C6h	Non-data
	Write Buffer	E8h	PIO data-out
	Write DMA	CAh	DMA
	Write Multiple	C5h	PIO data-out
Write Sector(s)	30h	PIO data-out	
Power Management Feature Set	Check Power Mode	E5h or 98h	Non-data
	Idle	E3h or 97h	Non-data
	Idle Immediate	E1h or 95h	Non-data
	Sleep	E6h or 99h	Non-data
	Standby	E2h or 96h	Non-data
	Standby Immediate	E0h or 94h	Non-data
Security Mode Feature Set	Security Set Password	F1h	PIO data-out
	Security Unlock	F2h	PIO data-out
	Security Erase Prepare	F3h	Non-data
	Security Erase Unit	F4h	PIO data-out
	Security Freeze Lock	F5h	Non-data
	Security Disable Password	F6h	PIO data-out



Command Set	Command	Command Code	Protocol
Host Protected Area Feature Set	Read Native Max Address	F8h	Non-data
	Set Max Address	F9h	Non-data
	Set Max Set Password	F9h	PIO data-out
	Set Max Lock	F9h	Non-data
	Set Max Freeze Lock	F9h	Non-data
	Set Max Unlock	F9h	PIO data-out
48-bit Address Feature Set <sup>1</sup>	Flush Cache Ext	EAh	Non-data
	Read Sector(s) Ext	24h	PIO data-in
	Read DMA Ext	25h	DMA
	Read Multiple Ext	29h	PIO data-in
	Read Native Max Address Ext	27h	Non-data
	Read Verify Sector(s) Ext	42h	Non-data
	Set Max Address Ext	37h	Non-data
	Write DMA Ext	35h	DMA
	Write DMA FUA Ext	3Dh	DMA
	Write Multiple Ext	39h	PIO data-out
	Write Multiple FUA Ext	CEh	PIO data-out
	Write Sector(s) Ext	34h	PIO data-out
CFA Feature Set	Erase Sectors	C0h	Non-data
	Request Sense	03h	Non-data
	Set Features Enable/Disable 8-bit Transfer	EFh	Non-data
	Translate Sector	87h	PIO data-in
	Write Multiple Without Erase	CDh	PIO data-out
	Write Sectors Without Erase	38h	PIO data-out
Others	Data Set Management	06h	DMA
	Seek	70h	Non-data
	Wear Level	F5h	Non-data

**Note<sup>1</sup>:** By default the 48-bit Address feature set is supported only in the models of 16GB storage capacity and above. This feature can be an option for small capacities if customers have the need.

## 4.2 Identify Device Data

The Identify Device command enables the host to receive parameter information from the FerriSSD. This command has the same protocol as the Read Sector(s) command. The parameter words in the buffer have the arrangement and meanings defined in the following table.

**Table 3: ID Table**

Word	F / V	Default Value	Description
0	F	044Ah	General configuration
1	X	XXXXh	Default number of cylinders
2	V	C837h	Specific configuration
3	X	00XXh	Default number of heads
4	X	0000h	Retired
5	X	0000h	Retired
6	F	XXXXh	Default number of sectors per track
7 - 8	V	XXXXh	Number of sectors per card (Word 7 = MSW, Word 8 = LSW)
9	X	0000h	Obsolete
10 - 19	F	XXXXh	Serial number in ASCII (Right justified)
20	X	0002h	Obsolete
21	X	0002h	Obsolete
22	X	0000h	Obsolete
23 - 26	F	XXXXh	Firmware revision in ASCII. Big Endian Byte Order in Word.
27 - 46	F	XXXXh	Model number in ASCII (Left justified). Big Endian Byte Order in Word.
47	F	8001h	Maximum number of sectors on Read/Write Multiple command
48	F	0000h	Reserved
49	F	0F00h	Capabilities
50	F	4000h	Capabilities
51	F	0200h	PIO data transfer cycle timing mode
52	X	0000h	Obsolete
53	F	0007h	Field validity
54	X	XXXXh	Current numbers of cylinders
55	X	XXXXh	Current numbers of heads
56	X	XXXXh	Current sectors per track
57 - 58	X	XXXXh	Current capacity in sectors (LBAs) (Word 57 = LSW, Word 58 = MSW)
59	F	0100h	Multiple sector setting
60 - 61	F	XXXXh	Total number of sectors addressable in LBA Mode

Word	F / V	Default Value	Description
62	X	0000h	Reserved
63	F	0007h	Multiword DMA transfer Supports MDMA Mode 0, 1 and 2
64	F	0003h	Advanced PIO modes supported
65	F	0078h	Minimum Multiword DMA transfer cycle time per word
66	F	0078h	Recommended Multiword DMA transfer cycle time
67	F	0078h	Minimum PIO transfer cycle time without flow control
68	F	0078h	Minimum PIO transfer cycle time with IORDY flow control
69 - 75	F	0000h	Reserved
76	F	0006h	Serial ATA capabilities Supports Serial ATA Gen1 and Gen2
77	F	0000h	Serial ATA Additional capabilities
78	F	0148h	Serial ATA features supported • Supports Device Sleep (option) • Supports software settings preservation (option) • Device supports initiating power management
79	V	XXXXh	Serial ATA features enabled
80	F	03FCh	Major version number (ATA8-ACS2)
81	F	0000h	Minor version number
82	F	742Bh	Command sets supported 0
83	F	7500h	Command sets supported 1
84	F	4002h	Command sets supported 2
85 - 87	V	XXXXh	Command set/feature enabled
88	V	007Fh	Ultra DMA mode supported and selected
89	F	0003h	Time required for Security erase unit completion
90	F	0000h	Time required for Enhanced security erase unit completion
91	V	0000h	Current Advanced power management value
92	V	FFFEh	Master Password Revision Code
93 - 99	V	0000h	Reserved
100 - 103	V	XXXXh	Maximum user LBA for 48-bit Address feature set
104 - 127	V	0000h	Reserved
128	V	0001h	Security status
129 - 159	X	0000h	Vendor unique bytes
160	F	0000h	Power requirement description
161 - 168	X	0000h	Reserved
169	F	0001h	Data Set Management supported (option)
170 - 216	V	0000h	Reserved
217	F	0100h	Non-rotating media (SSD)

Word	F / V	Default Value	Description
218 - 221	X	0000h	Reserved
222	F	101Fh	Transport major revision (SATA Rev 2.6)
223 - 254	X	0000h	Reserved
255	X	XXXXh	Integrity word

**Notes:**

1. F = content (byte) is fixed and does not change.
2. V = content (byte) is variable and may change depending on the state of the device or the commands executed by the device.
3. X = content (byte) is vendor specific and may be fixed or variable.

## 5. Environmental Conditions

### 5.1 Temperature

**Table 4: FerriSSD Module Temperature Support**

Parameter	Specifications
Operating Temperature	0°C ~ 70°C for the commercial version -40°C ~ +85°C for the industrial version
Non-Operating Temperature	-55°C to +85°C
Storage Temperature	-55°C to +85°C

### 5.2 Humidity

**Table 5: FerriSSD Module Humidity Support**

Parameter	Specifications
<b>Operating Humidity</b>	
Humidity	5% to 95% (Non condensation)
<b>Non-Operating Humidity</b>	
Humidity (Non condensation)	5% to 95%
Maximum Relative Humidity Gradient	20% per hour

### 5.3 RoHS

Directive of the European Parliament and of the Council on the Restriction of the Use of Certain Hazardous Substances in Electrical and Electronic Equipment, 2002/95/EC, January 2003. (RoHS Directive).

## 6. Reliability

### 6.1 Reliability Specifications

---

**Table 6: Reliability Specifications**

Type	UBER	MTBF
CommercialFerri	1 sector in $10^{16}$ bits read, max	1,200,000 hours
XtendFerri	1 sector in $10^{16}$ bits read, max	2,000,000 hours
EnterpriseFerri	1 sector in $10^{16}$ bits read, max	2,000,000 hours

**Notes:**

1. UBER: Uncorrectable bit error rate will not exceed one sector in the specified number of bits read. Refer to the JEDEC SSD specifications for detailed definition.
2. Mean Time Between Failure is estimated based on FIT value. FIT (Failure in Time) test is conducted at SMI internal test lab with SMI RDT (Reliability Demonstration Test).

### 6.2 Endurance

---

- CommercialFerri: 2,500 P/E cycles
- XtendFerri: 20,000 P/E cycles
- EnterpriseFerri: 50,000 P/E cycles

### 6.3 Preventive Maintenance

---

No preventive maintenance is required.

## 7. Ordering Information

### 7.1 Product Coding Rule

**Table 7: Product Code Definitions**

Example: M B 6 3 1 G X 8 □ BA □	
M	Module
B	Form Factor <ul style="list-style-type: none"> <li>• A = FerriSSD M25 (2.5" case)</li> <li>• B = FerriSSD M297 (half-slim)</li> <li>• C = FerriSSD M300 (mSATA)</li> <li>• D = FerriSSD M.2 (22 x 42 mm)</li> <li>• S = FerriSSD DOM (Type S)</li> </ul>
6	Ferri Family
3	Type / Interface <ul style="list-style-type: none"> <li>• 1 = CommercialFerri / SATA</li> <li>• 3 = EnterpriseFerri / SATA</li> <li>• 5 = XtendFerri / SATA</li> </ul>
1	Encryption Function <ul style="list-style-type: none"> <li>• 1 = Standard</li> <li>• 2 = Encryption Enabled</li> </ul>
G	Package: MCM TFBGA
X	Operating Temperature <ul style="list-style-type: none"> <li>• X = 0°C ~ 70°C (C-temp)</li> <li>• E = -40°C ~ +85°C (I-temp)</li> </ul>
8	Capacity <ul style="list-style-type: none"> <li>• 1 = 1GB</li> <li>• 2 = 2GB</li> <li>• 4 = 4GB</li> <li>• 8 = 8GB</li> <li>• A = 16GB</li> <li>• B = 32GB</li> <li>• C = 64GB</li> </ul>
□	PCB Revision
BA/BB/BC/BD	Product Revision
□	BOM Version

Note: Refer to the FerriSSD Product Selection Guide for valid ordering numbers.