

注記 NOTES

- △ 接点部までの嵌合長さ。  
LENGTH TO CONTACT POINT.
- 2. 使用材料 MATERIAL  
ハウジング : 46ナイロン, UL94V-0  
HOUSING : 46NYLON, UL94V-0  
アクチュエータ : PPS, UL94V-0  
ACTUATOR : PPS, UL94V-0  
ターミナル : リン青銅 (t=0.25)  
TERMINAL : PHOS-BRO.(t=0.25)  
メッキ : 錫ビスマスメッキ 1. 0マイクロメートル以上  
PLATING : TIN-BISMUTH 1.0 MICROMETER MINIMUM  
メッキ : ニッケル下地 1. 0マイクロメートル以上  
PLATING : NICKEL(UNDER PLATING) 1.0 MICROMETER MINIMUM  
金具 : 銅合金 (t=0.25)  
FITTING NAIL : COPPER ALLOY (t=0.25)  
メッキ : 錫メッキ 1. 0マイクロメートル以上  
PLATING : TIN 1.0 MICROMETER MINIMUM  
メッキ : ニッケル下地 1. 0マイクロメートル以上  
PLATING : NICKEL(UNDER PLATING) 1.0 MICROMETER MINIMUM
- △ 3. パターンはくり止め用金具  
FITTING NAIL FOR PREVENTION OF PEELING OF P.C.B.PATTERN.
- 4. エンボステープ梱包時は、アクチュエータがロックした状態とする。  
WHEN CONNECTOR IS SHIPPED, ACTUATOR SHOULD BE LOCKED.
- △ 5. FPC挿入深さ。  
INSERTION DEPTH OF FPC
- △ 6. パターン書き込み禁止エリア。  
NO FOOT PRINT AREA.
- 7. 本製品は 5 2 2 7 1 - \* \* 9 0 の鉛フリー品である。  
THIS PRODUCT IS LEAD FREE OF 52271-\*\*90
- △ 8. テール及び金具の平坦度は、0.15以下とする。  
TAIL AND NAIL COPLANARITY TO BE 0.15 MAXIMUM.

35	31.2	29	52271-3079	30
34	30.2	28	52271-2979	29
33	29.2	27	52271-2879	28
32	28.2	26	52271-2779	27
31	27.2	25	52271-2679	26
30	26.2	24	52271-2579	25
29.0	25.2	23	52271-2479	24
28.0	24.2	22	52271-2379	23
27.0	23.2	21	52271-2279	22
26.0	22.2	20	52271-2179	21
25.0	21.2	19	52271-2079	20
24.0	20.2	18	52271-1979	19
23.0	19.2	17	52271-1879	18
22.0	18.2	16	52271-1779	17
21.0	17.2	15	52271-1679	16
20.0	16.2	14	52271-1579	15
19.0	15.2	13	52271-1479	14
18.0	14.2	12	52271-1379	13
17.0	13.2	11	52271-1279	12
16.0	12.2	10	52271-1179	11
15.0	11.2	9	52271-1079	10
14.0	10.2	8	52271-0979	9
13.0	9.2	7	52271-0879	8
12.0	8.2	6	52271-0779	7
11.0	7.2	5	52271-0679	6
10.0	6.2	4	52271-0579	5
9.00	5.2	3	52271-0479	4
C	B	A	EMBOSSED PACKAGE	CKT No.
			Order No.	

THIS DRAWING CONTAINS INFORMATION THAT IS PROPRIETARY TO MOLEX ELECTRONIC TECHNOLOGIES, LLC AND SHOULD NOT BE USED WITHOUT WRITTEN PERMISSION						
DIMENSION UNITS <b>mm</b>	SCALE <b>8:1</b>	CURRENT REV DESC:				
GENERAL TOLERANCES (UNLESS SPECIFIED)		<p style="text-align: center;"><b>molex</b></p> <p style="text-align: center;">1.0 FPC CONN ZIF SMT (BOTTOM CONTACT) -LEAD FREE-</p> <p style="text-align: center;">PRODUCT CUSTOMER DRAWING</p>				
ANGULAR TOL	± 3.0 °					
4 PLACES	± 0.2					
3 PLACES	± 0.2					
2 PLACES	± 0.2					
1 PLACE	± 0.25					
0 PLACES	± 0.3					
DRAFT WHERE APPLICABLE MUST REMAIN WITHIN DIMENSIONS	THIRD ANGLE PROJECTION	DRAWING	SERIES	MATERIAL NUMBER	CUSTOMER	SHEET NUMBER
		A3-SIZE	52271	SEE TABLE	GENERAL MARKET	1 OF 2



NOTES

- 製品番号 52271-\*\*-19 の梱包状態はアクチュエータがロックした状態とする。  
IN THE PACKAGE, ACTUATOR OF PART NO. 52271-\*\*-19 SHOULD BE LOCKED RE DETAILED DIMENSIONS, SEE SD-52271-036.
- 梱包数量: 1000個/リール  
NUMBER OF CONNECTORS: 1000 PCS/REEL
- リードテープ長さ LEAD TAPE LENGTH  

トップテープ リーダー部 TOP TAPE LEADER PART	トップテープ 未接着部 TOP TAPE NON-BONDED PART
175 ±25	25 ±5
- トップテープの剥離強度: 0.1~1.3N (10~130gf) (剥離方向は下図参照)  
尚、本規格値は、出荷時に適用。(但し、輸送時に剥離が発生しない事。)  
PEELING OFF FORCE OF TOP TAPE: 0.1~1.3N (10~130gf)  
(PEELING DIRECTION AS SHOWN IN FOLLOWING FIG.)  
THIS REQUIREMENT SHOULD BE APPLIED AT SHIPMENT  
PEEL OFF SHOULD NOT BE ALLOWED, DURING TRANSPORTATION
- 材料 (MATERIAL)  
キャリアテープ (CARRIER TAPE): ポリプロピレン (POLYPROPYLENE)  
トップテープ (TOP TAPE): PET, PE, PEF  
リール (REEL): ポリスチレン (PS) <リサイクル材を含む>  
POLYSTYRENE (PS) <RECYCLE MATERIAL CONTAINED>
- 本製品は52271-\*\*-19の鉛フリー品である。  
THIS PRODUCT IS LEAD FREE OF 52271-\*\*-19.
- 本製品は乾燥剤入り、ハイバリア梱包仕様である。  
THIS PRODUCT IS HIGH BARRIER PACKAGE WITH DESICCANT.

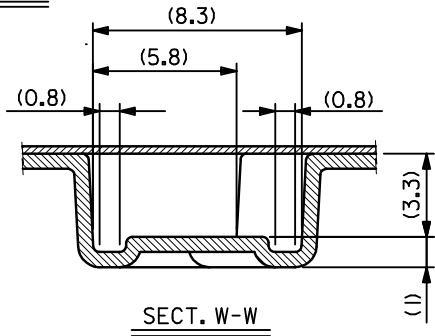
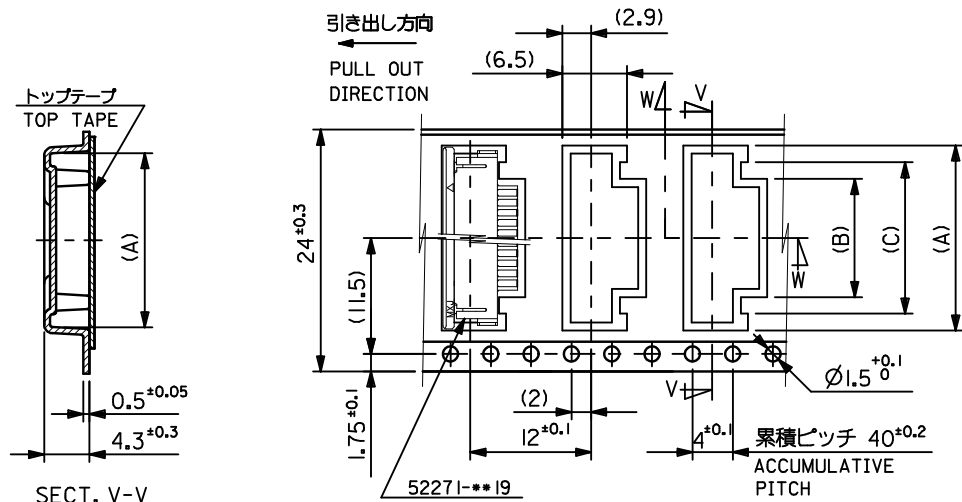
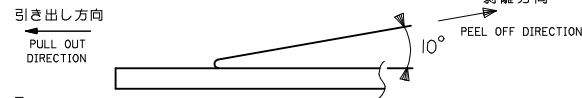
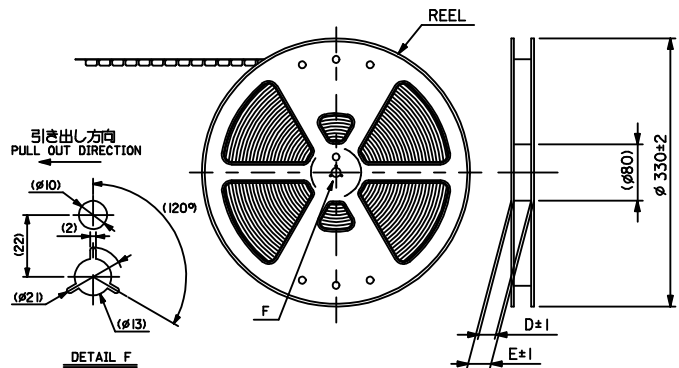

24	29.4	25.4	15	11.4	18.3	52271-1179	11
			14	10.4	17.3	-1079	10
			13	9.4	16.3	-0979	9
			12	8.4	15.3	-0879	8
			11	7.4	14.3	-0779	7
			10	6.4	13.3	-0679	6
			9	5.4	12.3	-0579	5
			8	4.4	11.3	52271-0479	4
			(C)	(B)	(A)	52271-0479	4

REVISED EC NO: J2009-2061 DRWN:TKON CHKD:HMATSUMOTO APPR:NIKI ITA	DESCRIPTION 2009/05/20 2009/05/21 2009/05/21	GENERAL TOLERANCES (UNLESS SPECIFIED)	DIMENSION STYLE MM ONLY	SCALE ---	DESIGN UNITS METRIC	THIRD ANGLE PROJECTION
		10 UNDER ±0.2	DRAWN BY H. KAWABATA	DATE 2004/03/12	TITLE EMBOSSED TAPE PACKAGE FOR 52271-**-19 -LEAD FREE-	
		10 OVER 30 UNDER ±0.25	CHECKED BY K. TOJO	DATE 2004/03/12	MOLEX INCORPORATED	
		30 OVER ±0.3	APPROVED BY M. SASAO	DATE 2004/03/12	DOCUMENT NO. SD-52271-037	
ANGULAR ±3		DRAFT WHERE APPLICABLE MUST REMAIN WITHIN DIMENSIONS	SIZE A3	THIS DRAWING CONTAINS INFORMATION THAT IS PROPRIETARY TO MOLEX INCORPORATED AND SHOULD NOT BE USED WITHOUT WRITTEN PERMISSION		

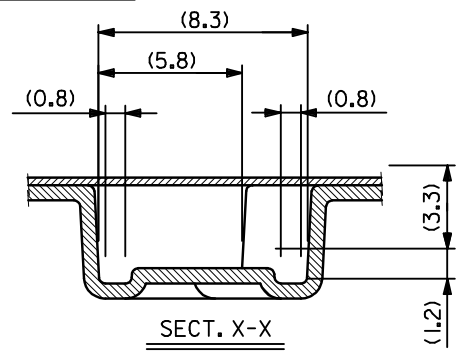
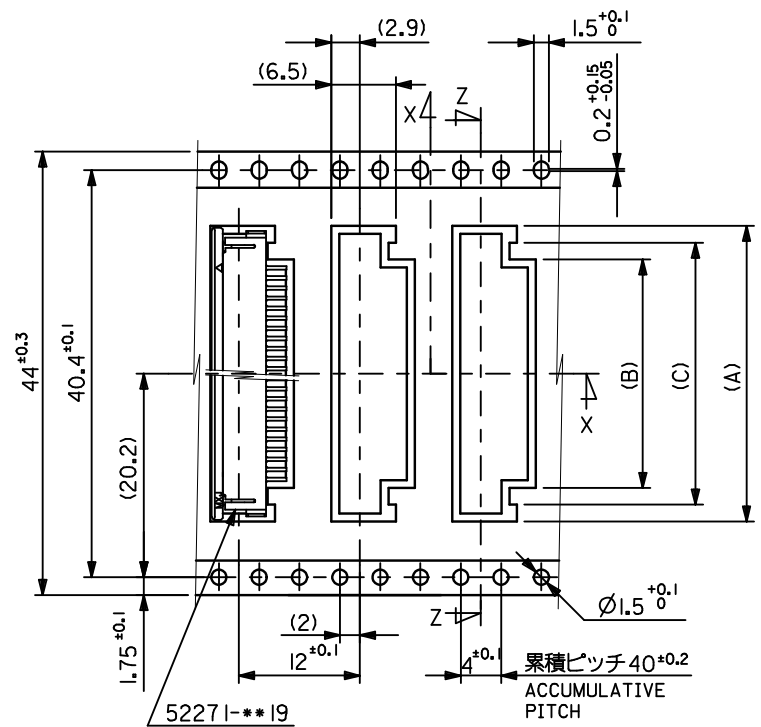
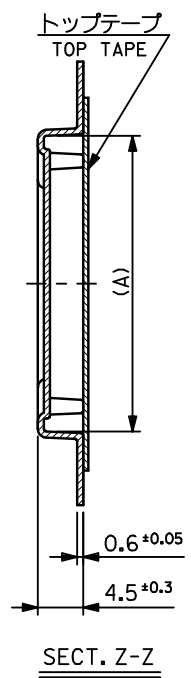
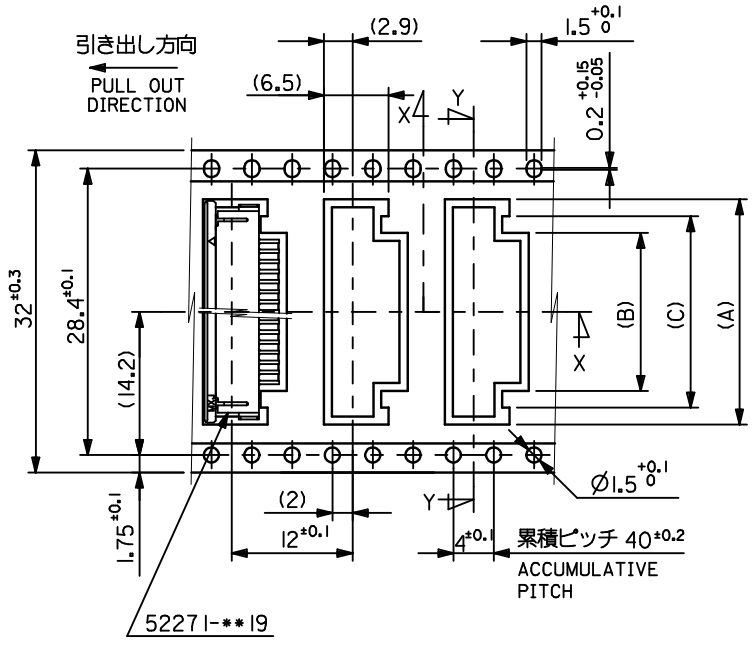
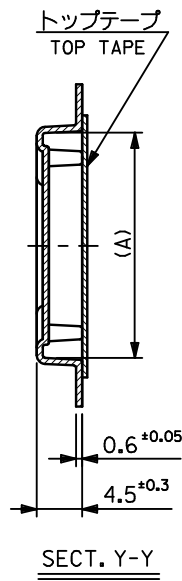

44	49.4	45.4	31	27.4	34.35	52271-2779	27
			30	26.4	33.35	-2679	26
			29	25.4	32.35	-2579	25
			28	24.4	31.35	-2479	24
			27	23.4	30.35	-2379	23
			26	22.4	29.35	-2279	22
			25	21.4	28.35	-2179	21
			24	20.4	27.35	-2079	20
			23	19.4	26.35	-1979	19
			22	18.4	25.35	-1879	18
			21	17.4	24.35	-1779	17
			20	16.4	23.35	-1679	16
			19	15.4	22.35	-1579	15
			18	14.4	21.35	-1479	14
32	37.4	33.4	17	13.4	20.35	-1379	13
			16	12.4	19.35	52271-1279	12
			(C)	(B)	(A)	MATERIAL NO.	
							電 数 CKT.

キャリアテープ幅  
CARRIER TAPE WIDTH  
fb\_frame\_A3\_J\_ME\_S  
Rev. E 2006/04/15

REVISED EC NO.: J2009-2061 DRWN:TKON 2009/05/20 CHKD:HATSUMOTO 2009/05/21 APPR:NIKI ITA 2009/05/21 REV: A	DESCRIPTION GENERAL TOLERANCES (UNLESS SPECIFIED) 10 UNDER ±0.2 10 OVER 30 UNDER ±0.25 30 OVER ±0.3 ANGULAR ±3° DRAFT WHERE APPLICABLE MUST REMAIN WITHIN DIMENSIONS	DIMENSION STYLE MM ONLY	SCALE ---	DESIGN UNITS METRIC	THIRD ANGLE PROJECTION	
		DRAWN BY H. KAWABATA	DATE 2004/03/12	TITLE EMBOSSED TAPE PACKAGE FOR 52271-**-19 -LEAD FREE-		
		CHECKED BY K. TOJO	DATE 2004/03/12	MOLEX INCORPORATED		
		APPROVED BY M. SASAO	DATE 2004/03/12	MATERIAL NO. SEE TABLE		DOCUMENT NO. SD-52271-037
SIZE A3		THIS DRAWING CONTAINS INFORMATION THAT IS PROPRIETARY TO MOLEX INCORPORATED AND SHOULD NOT BE USED WITHOUT WRITTEN PERMISSION				

52271-\*\*-79  
MODEL NO.

SHEET NO.  
2 OF 3

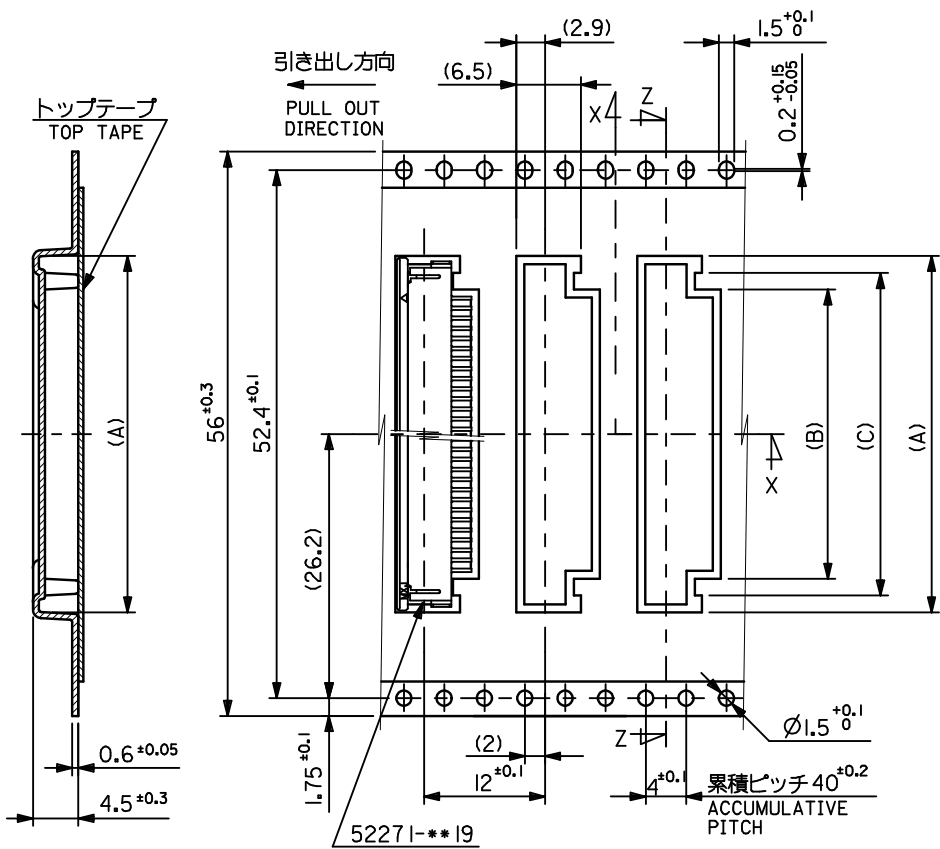

SECT. Z-Z

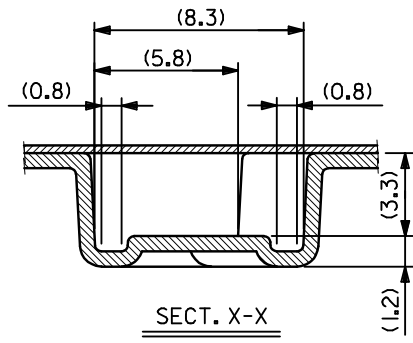

SECT. X-X

56	61.4	57.4	34	30.4	37.35	52271-3079	30
			33	29.4	36.35	52271-2979	29
			32	28.4	35.35	52271-2879	28
キャリアテープ幅 CARRIER TAPE WIDTH	E	D	(C)	(B)	(A)	MATERIAL NO.	種 数 CKT.

tb\_frame\_A3\_J\_ME\_S  
Rev. E 2006/04/15

REVISED	EC NO.: J2009-2061	2009/05/20
	DRWN:TKON	2009/05/21
	CHKD:HMATSUMOTO	2009/05/21
	APPR:NUKITA	2009/05/21
REV	DESCRIPTION	
A		

GENERAL TOLERANCES (UNLESS SPECIFIED)	
10 UNDER	±0.2
10 OVER 30 UNDER	±0.25
30 OVER	±0.3
ANGULAR ±3°	
DRAFT WHERE APPLICABLE MUST REMAIN WITHIN DIMENSIONS	

DIMENSION STYLE MM ONLY	
DRAWN BY	DATE
H. KAWABATA	2004/03/12
CHECKED BY	DATE
K. TOJO	2004/03/12
APPROVED BY	DATE
M. SASAO	2004/03/12
MATERIAL NO.	
SEE TABLE	
SIZE	
A3	

SCALE	DESIGN UNITS	THIRD ANGLE PROJECTION
---	METRIC	☉ □
MODEL NO.		52271-**-79
TITLE		
EMBOSSSED TAPE PAKEGE FOR 52271-**-19 -LEAD FREE-		
MATERIAL NO.		SHEET NO.
SEE TABLE		3 OF 3
DOCUMENT NO.		
SD-52271-037		
THIS DRAWING CONTAINS INFORMATION THAT IS PROPRIETARY TO MOLEX INCORPORATED AND SHOULD NOT BE USED WITHOUT WRITTEN PERMISSION		