

**= Dimension of coil unit =**

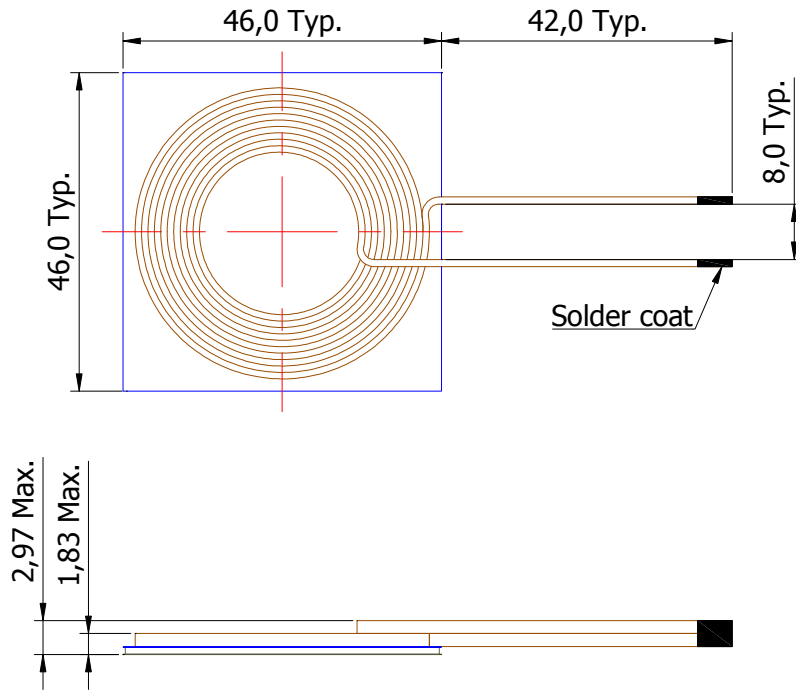

**= Coil unit Assembly=**

Unit : mm

Stack	TDK Item	Typ.	Max.
1	Coil+Resin	0.940	1.110
	Coil+Resin	0.940	1.110
2	Adhesive Tape	0.135	0.142
3	PET Tape	0.030	0.032
4	Ferrite Sheet	0.500	0.550
5	PET Tape	0.030	0.032
Total Thickness (Wire Parts)		1.64	1.83
Total Thickness (Cross Wire Parts)		2.58	2.97

**= Electrical Characteristics=**

- Ls : 7.3 uH Typ. @100kHz
- Rs : 0.07 Ω Max. @100kHz

