

LOC		DIST		REVISIONS			
P	LTR	DESCRIPTION	DATE	DNW	APVD		
T		REV PER ECO 15-016064	11-9-15	CT	CD		

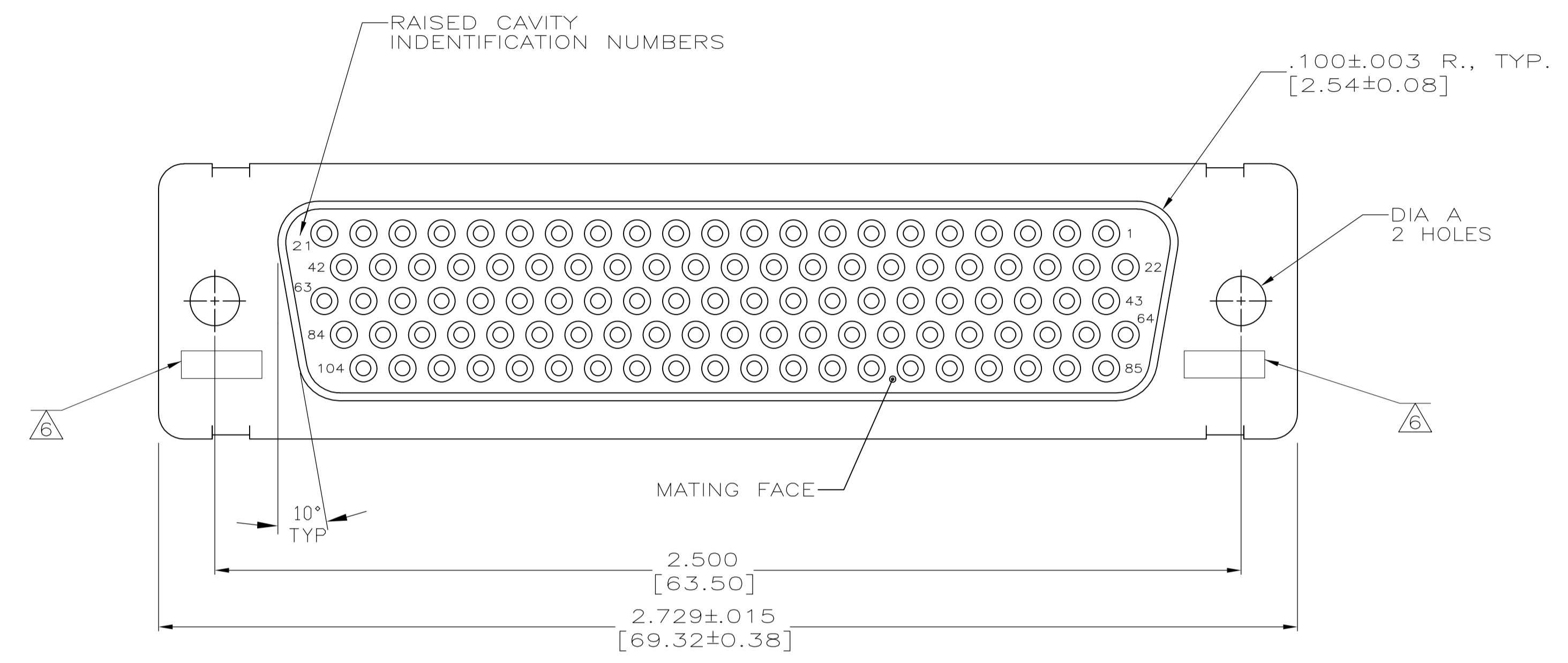

- THIS RECEPTACLE WILL MATE WITH ANY PLUG CONNECTOR WITH THE SAME INSERT ARRANGEMENT AS DEFINED BY MS14004-1.
- MAXIMUM WIRE INSULATION USED WITH THIS RCPT. IS .054 [1.37] DIA.
- Be-Cu RETENTION CLIPS ARE INCLUDED IN INSERTS.
- INSPECTION REQUIREMENTS PER R4383.
- CONNECTOR SUPPLIED WITH 115 CONTACTS, AMP PART NUMBER 206071-1. INSPECTION REQUIREMENTS PER R4383 WITHOUT TESTS FOR HIGH ALTITUDE DIELECTRIC WITHSTANDING VOLTAGE AS CALLED FOR IN TABLE II SCREENING AND TESTING.
- UL/CSA DESIGNATION STAMPED IN THIS AREA, OPTIONAL.
- SPECIAL TESTING PER GE DOCUMENT 20025720. CONNECTOR SUPPLIED WITH 114 CONTACTS, AMP P/N 206071-1.
- RESTRICTED TO CAE ELECTRONICS ONLY.
- THESE CONNECTORS ARE QUALIFIED TO GODDARD SPACE FLIGHT CENTER SPECIFICATION S-311-P-4.

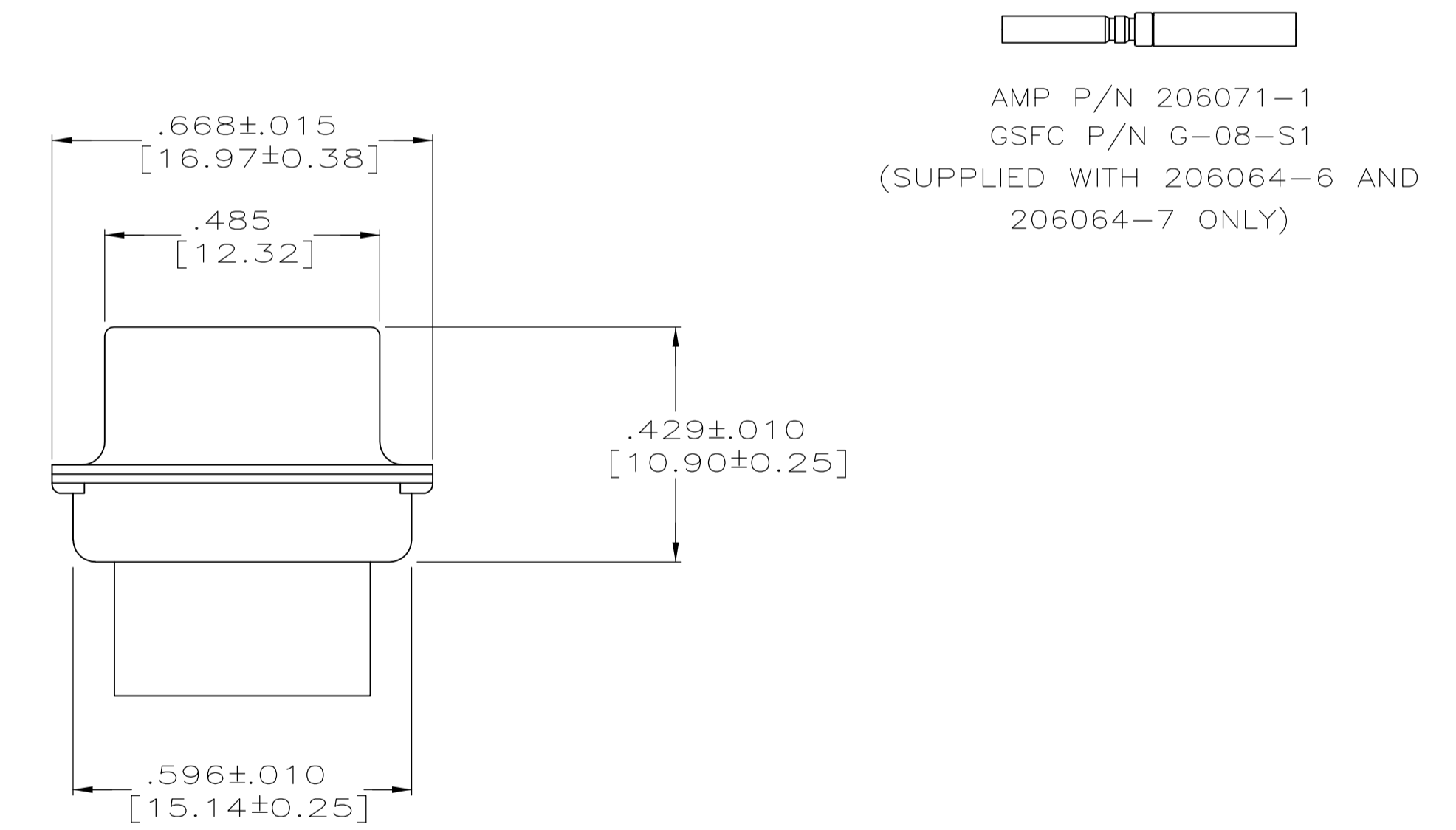
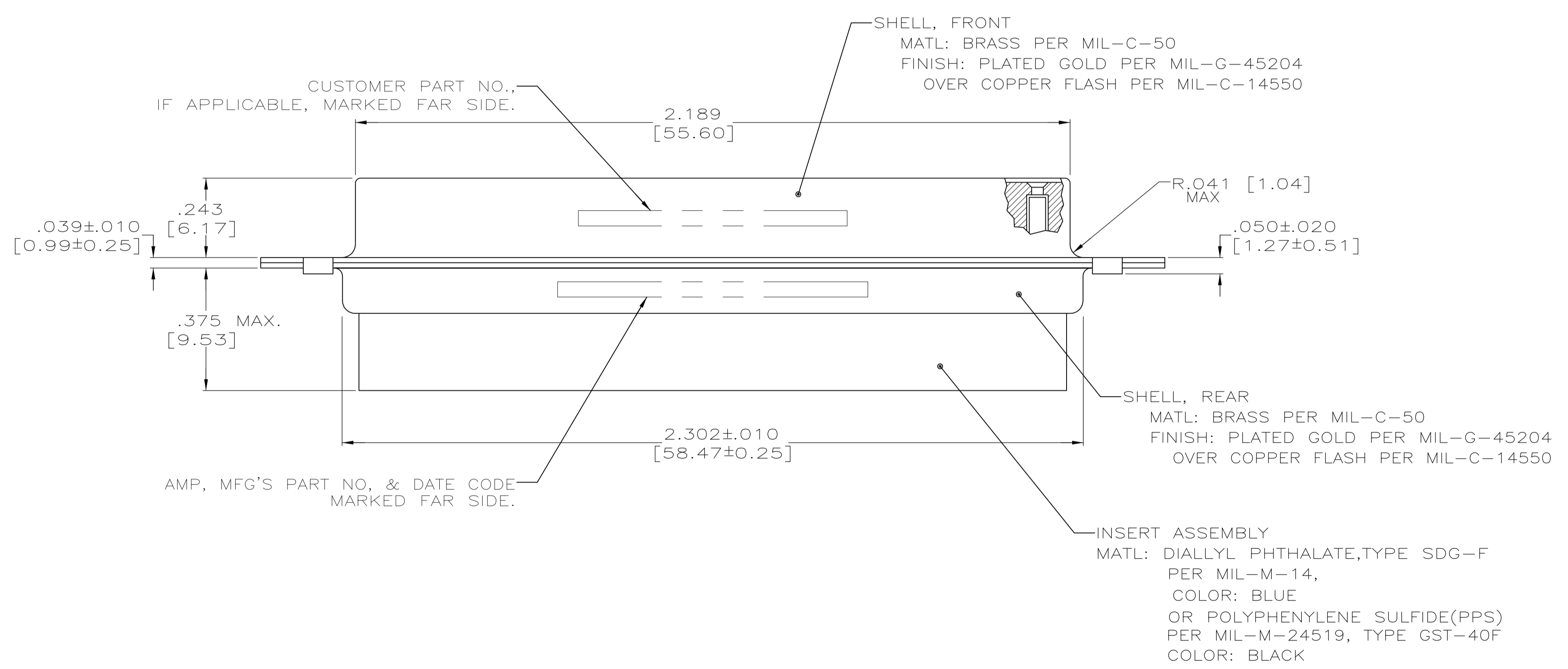

8/9	.120 [3.05]	570566-6	206065-9	206065-9
7	.120 [3.05]	311P407-6S-B-12	206065-4	206065-8
5	.120 [3.05]	20025720P1104S	206065-7	206065-7
4	.120 [3.05]	R4383P104S	206065-6	206065-6
3	.120 [3.05]	R4383P104S-2	206065-5	206065-5
2	.120 [3.05]	311P407-6S-B-12	206065-4	206065-4
1	.154 [3.91]	---	206065-3	206065-3
9	.154 [3.91]	311P407-6S-B-15	206065-2	206065-2
0	.120 [3.05]	R9259P104S	206065-1	206065-1
REMARKS	DIA A	CUSTOMER P/N ON CONNECTOR	AMP P/N ON CONNECTOR	PART NO.

THIS DRAWING IS A CONTROLLED DOCUMENT.

DTN: S. GLATFELTER 11-10-88
CHK: F. A. McDOUGLE 11-10-88
APP'D: F. A. McDOUGLE 11-10-88

NAME: AMPLIMITE NONMAGNETIC RECEPTACLE ASSEMBLY, SERIES 90, SHELL SIZE 6, 104 POSITION

APPLICATION SPEC: ---
WEIGHT: ---
CUSTOMER DRAWING

SCALE: 4:1 SHEET 1 OF 1 REV T

STE TE Connectivity