

Single Cell Li-Ion Battery Charger with Adjustable Charging Current for Portable Applications

General Description

The RT9527 is a low cost single-cell Li-ion charger for low current charge applications.

The RT9527 can be powered up from an AC adapter or USB (Universal Serial Bus) port inputs. The RT9527 enters sleep mode when VIN power is removed. The RT9527 optimizes the charging task by using a control algorithm, which includes pre-charge mode, fast-charge mode and constant voltage mode. The charging task is kept in constant voltage mode to hold the battery in a full charge condition. The charge current is adjustable via an external resistor. The internal thermal feedback circuitry regulates the die temperature to optimize the charge rate for all ambient temperatures. The RT9527 features 28V maximum rating voltages for VIN. Other features include under voltage protection and over voltage protection for the AC adapter supply.

The RT9527 is available in a WDFN-8L 2x2 package.

Ordering Information

RT9527□□

- Package Type
QW : WDFN-8L 2x2 (W-Type)
- Lead Plating System
G : Green (Halogen Free and Pb Free)

Note :

Richtek products are :

- ▶ RoHS compliant and compatible with the current requirements of IPC/JEDEC J-STD-020.
- ▶ Suitable for use in SnPb or Pb-free soldering processes.

Features

- 28V Maximum Rating for AC Adapter
- Internal Integrated Power FETs
- Adjustable Charging Current
- Programmable Safe Charge Timer
- NTC Thermistor Input
- Battery Reverse Protection
- ISET Pin Short Protection
- Charge Status Indicator
- AC Adapter Power Good Status Indicator
- End of Charge Current is 10% of Fast-Charge Current
- Under Voltage Protection
- Over Voltage Protection
- Thermal Feedback Optimized Charge Rate
- Small Thermally Enhanced 8-Lead WDFN Package
- RoHS Compliant and Halogen Free

Applications

- Cellular Phones
- Digital Cameras
- PDAs and Smart Phone
- Portable Instruments

Marking Information

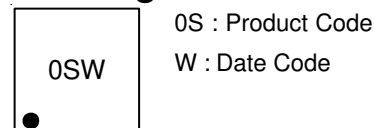

Simplified Application Circuit

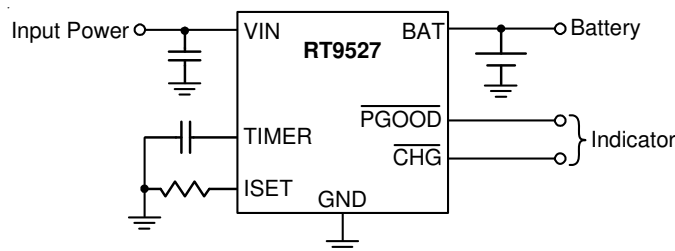

Pin Configuration

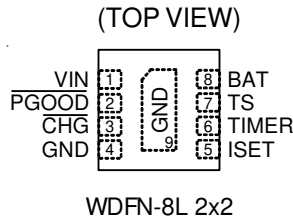

Functional Pin Description

Pin No.	Pin Name	Pin Function
1	VIN	Supply voltage input. VIN can withstand up to 28V input.
2	$\overline{\text{PGOOD}}$	Power good status output. Active-low, open-drain output.
3	$\overline{\text{CHG}}$	Charger status output. Active-low, open-drain output.
4, 9 (Exposed Pad)	GND	Ground. The exposed pad must be soldered to a large PCB and connected to GND for maximum power dissipation.
5	ISET	Charge current setting.
6	TIMER	Safe-charge timer setting.
7	TS	Temperature sense input. The TS pin connects to a battery's thermistor to determine whether the battery is too hot or too cold for charging operation. If the battery's temperature is out of range, charging is paused until it re-enters the valid range.
8	BAT	Charge current output for battery.

Functional Block Diagram

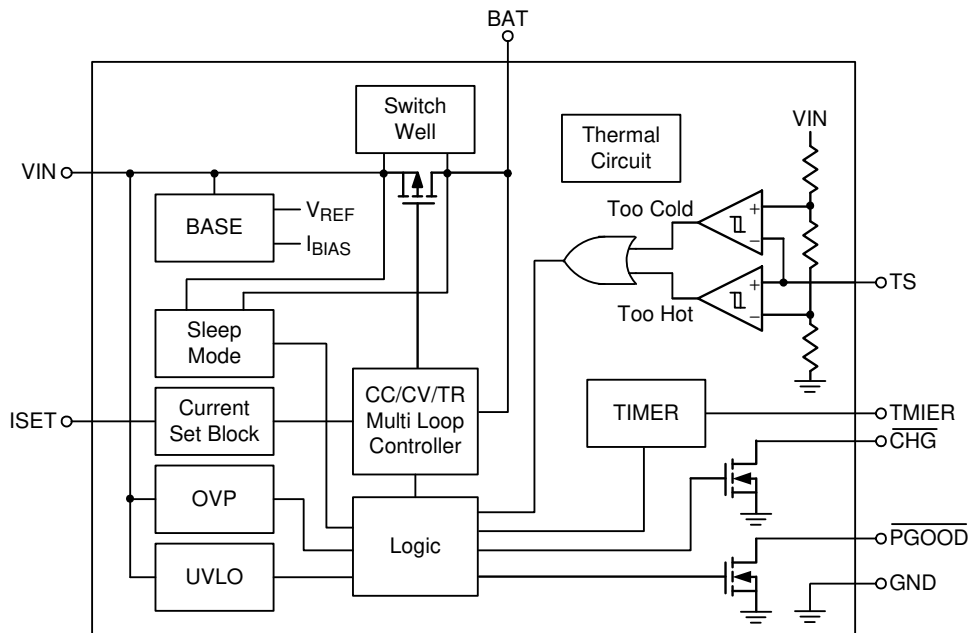

Operation

The RT9527 is a Li-ion charger that can support the input voltage range from 4.4V to 6V. It provides a wide fast-charge current setting ranging from 10mA up to 600mA.

Change Current Setting

The charging current is adjustable via an external resistor between the ISET and GND pin.

UVLO

If the input voltage (VIN) is lower than the threshold voltage $V_{UVLO} - \Delta V_{UVLO}$, the charger will stop charging until VIN is larger than V_{UVLO} .

OVP

If the input voltage (VIN) is higher than the threshold voltage V_{OVP} , the internal OVP signal will go high and the charger will stop charging until VIN is below $V_{OVP} - \Delta V_{OVP}$.

Switch Well

The switch well will choose the highest voltage between VIN and BAT to prevent the power switch from damage.

Sleep Mode

When the voltage difference between VIN and BAT is under V_{OS_L} , the charger will enter sleep mode to save the system power consumption.

CC/CV/TR Multi Loop Controller

There are constant current loop, constant voltage loop and thermal regulation loop to control the charging current.

Too Hot or Too Cold

The temperature sense input TS pin can be connected a thermistor to determine whether the battery is too hot or too cold for charging operation. If the battery's temperature is out of range, charging is paused until it re-enters the valid range.

PGOOD

The PGOOD is an open-drain output used to indicate the input voltage status. PGOOD will assert low when VIN is in the proper working range.

CHG

The CHG pin is an open-drain output. CHG will assert low when the charger starts to charge the battery and become high impedance when the termination current is reached.

TIMER

The charger contains the safety timer. When the charging time is longer than t_{PCHG} in the pre-charge mode or t_{FCHG} in the fast-charge mode, time fault happens. Then, the charger will be turned off and the CHG pin will become high impedance.

Absolute Maximum Ratings (Note 1)

• Supply Input Voltage, V_{IN} -----	-0.3V to 28V
• CHG, PGOOD, TS -----	-0.3V to 28V
• Other Pins -----	-0.3V to 6V
• Power Dissipation, $P_D @ T_A = 25^\circ\text{C}$	
WDFN-8L 2x2 -----	2.19W
• Package Thermal Resistance (Note 2)	
WDFN-8L 2x2, θ_{JA} -----	45.5°C/W
WDFN-8L 2x2, θ_{JC} -----	11.5°C/W
• Lead Temperature (Soldering, 10 sec.) -----	260°C
• Junction Temperature -----	150°C
• Storage Temperature Range -----	-65°C to 150°C
• ESD Susceptibility (Note 3)	
HBM (Human Body Model) -----	2kV

Recommended Operating Conditions (Note 4)

• Supply Input Voltage, V_{IN} -----	4.4V to 6V
• Junction Temperature Range -----	-40°C to 125°C
• Ambient Temperature Range -----	-40°C to 85°C

Electrical Characteristics

($V_{IN} = 5V$, $V_{BAT} = 4V$, $T_A = 25^\circ\text{C}$, unless otherwise specified)

Parameter	Symbol	Test Conditions	Min	Typ	Max	Unit
Supply Input						
VIN Under Voltage Lockout Threshold	V_{UVLO}	$V_{IN} = 0V$ to 5V	3.1	3.3	3.5	V
VIN Under Voltage Lockout Hysteresis	ΔV_{UVLO}	$V_{IN} = 5V$ to 0V	--	240	--	mV
VIN – BAT VOS Rising	V_{OS_H}		--	100	200	mV
VIN – BAT VOS Falling	V_{OS_L}		10	50	--	mV
VIN Standby Current	$I_{STANDBY}$	$V_{BAT} = 4.5V$	--	1	2	mA
BAT Sleep Leakage Current	I_{SLEEP}	$V_{IN} = 0V$	--	--	1	μA
Voltage Regulation						
Battery Voltage Regulation	V_{REG}	0°C to 85°C	4.158	4.2	4.242	V
Re-Charge Threshold	ΔV_{REGCHG}	Battery Regulation – Recharge Level	60	100	140	mV
VIN Power FET On-Resistance	$R_{DS(ON)}$	$I_{BAT} = 450\text{mA}$	--	0.8	--	Ω
Current Regulation						
VIN Charge Setting Range	I_{CHG}		10	--	600	mA
Fast-Charge Current Factor	K_{CHG_F1}	$I_{CHG_F1} = K_{CHG_F1} / R_{ISET}$, $I_{CHG_F1} = 10\text{mA}$ to 50mA	510	600	690	A Ω
	K_{CHG_F2}	$I_{CHG_F2} = K_{CHG_F2} / R_{ISET}$, $I_{CHG_F2} = 50\text{mA}$ to 600mA	570	600	630	

Parameter	Symbol	Test Conditions	Min	Typ	Max	Unit
Pre-Charge Current Factor	K _{CHG_P}	I _{CHG_P} = K _{CHG_P} / R _{ISET}	30	60	90	AΩ
Pre-Charge						
BAT Pre-Charge Threshold	V _{PRECH}	V _{BAT} Falling	2.7	2.8	2.9	V
BAT Pre-Charge Threshold Hysteresis	ΔV _{PRECH}		--	200	--	mV
Charge Termination						
Termination Current Ratio	I _{TERMI}	V _{BAT} > V _{PREC} , I _{CHG} < I _{TERMI} , CHG = L to H	5	10	15	%
Protection						
Thermal Regulation	T _{REG}		--	125	--	°C
Over Voltage Protection	V _{OVP}		6.2	6.5	6.8	V
Over Voltage Protect Hysteresis	ΔV _{OVP}		--	0.2	--	V
ISET Pin Short Protection	R _{SHORT}		375	500	625	Ω
NTC						
Cold Temperature Fault Threshold Voltage	V _{COLD}	Rising Threshold	60	61	62	%V _{IN}
Cold Temperature Fault Threshold Hysteresis	ΔV _{COLD}		--	2	--	%V _{IN}
Hot Temperature Fault Threshold Voltage	V _{HOT}	Falling Threshold	29	30	31	%V _{IN}
Hot Temperature Fault Threshold Hysteresis	ΔV _{HOT}		--	2	--	%V _{IN}
Timer						
Pre-Charge Fault Time	t _{PCHG}	C _{TIMER} = 1μF (1 / 8 x t _{FCHG})	1440	1800	2160	s
Fast-Charge Fault Time	t _{FCHG}	C _{TIMER} = 1μF	11520	14400	17280	s
Other						
PGOOD Pull Down Voltage	V _{PGOOD}	I _{PGOOD} = 5mA	--	200	--	mV
CHG Pull Down Voltage	V _{CHG}	I _{CHG} = 5mA	--	200	--	mV
PGOOD Deglitch Time	t _{PGOOD}	Time measured from the edge V _{IN} = 0V to 5V in 1μs to PGOOD = L	--	2	--	ms
Input Over Voltage Blanking Time	t _{OVP}		--	50	--	μs
Input Over Voltage Recovery Time	t _{OVP_R}		--	2	--	ms
Pre-Charge to Fast-Charge Deglitch Time	t _{PF}		--	25	--	ms
Fast-charge to Pre-Charge Deglitch Time	t _{FP}		--	25	--	ms
Termination Deglitch Time	t _{TERMI}		--	25	--	ms
Recharge Deglitch Time	t _{RECHG}		--	100	--	ms
Sleep Deglitch Time	t _{NO-IN}		--	25	--	ms
Pack Temperature Fault Detection Deglitch Time	t _{TS}		--	25	--	ms

- Note 1.** Stresses beyond those listed “Absolute Maximum Ratings” may cause permanent damage to the device. These are stress ratings only, and functional operation of the device at these or any other conditions beyond those indicated in the operational sections of the specifications is not implied. Exposure to absolute maximum rating conditions may affect device reliability.
- Note 2.** θ_{JA} is measured at $T_A = 25^\circ\text{C}$ on a high effective thermal conductivity four-layer test board per JEDEC 51-7. θ_{JC} is measured at the exposed pad of the package.
- Note 3.** Devices are ESD sensitive. Handling precaution is recommended.
- Note 4.** The device is not guaranteed to function outside its operating conditions.

Typical Application Circuit

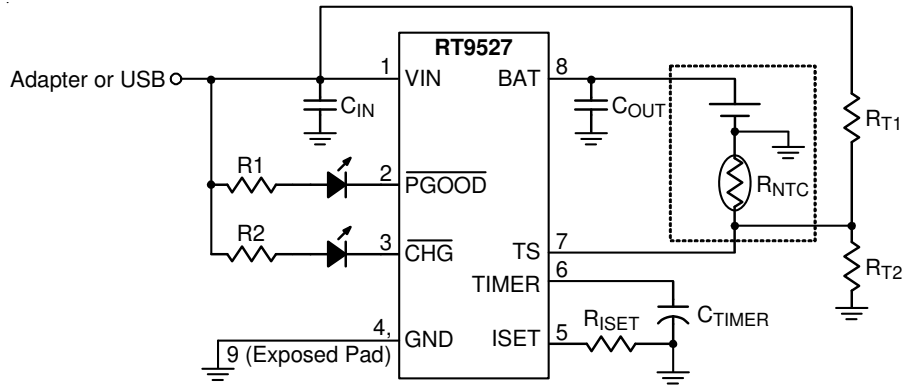

Typical Operating Characteristics

Charge On/Off Control from VIN

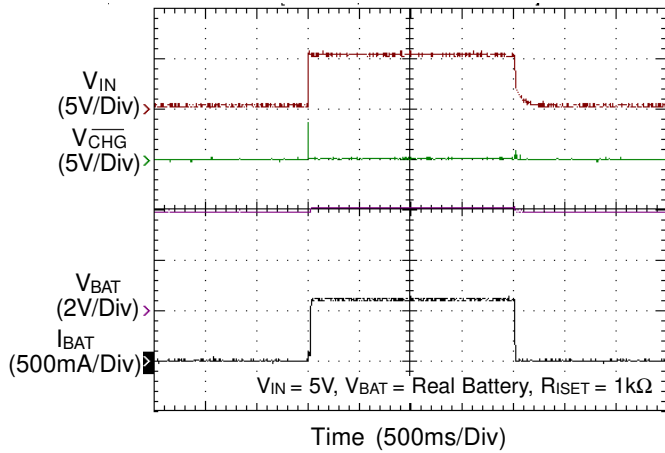

TS Inserted/Removed

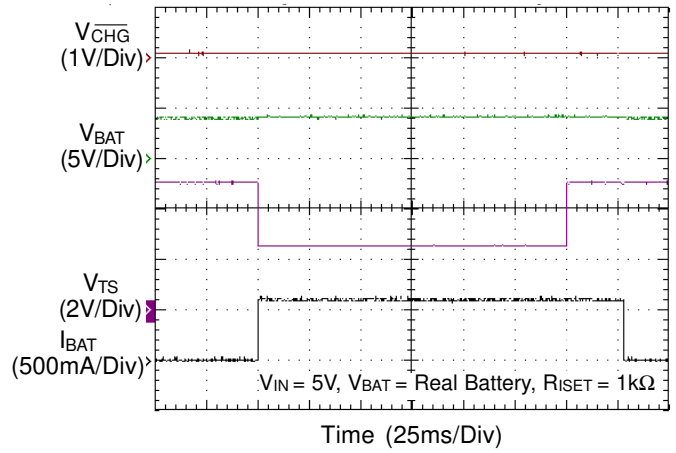

VIN Hot-Plug with NTC/Without Battery

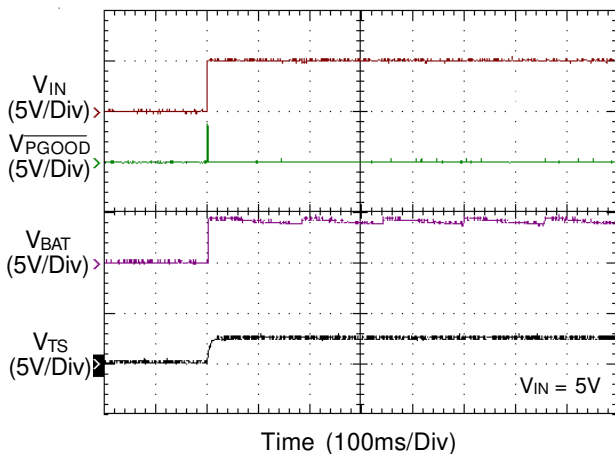

VIN Hot-Plug Without NTC/Battery

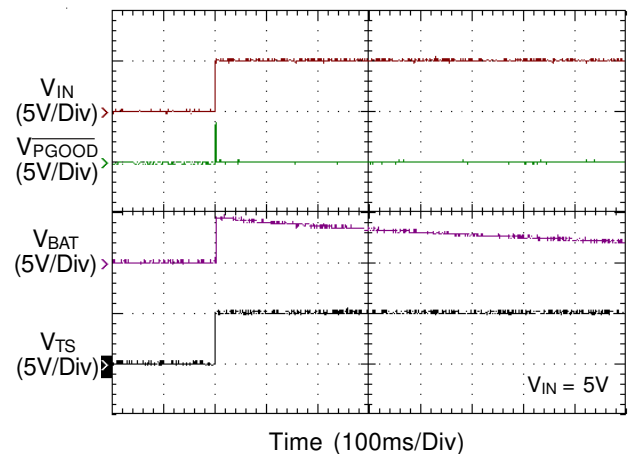

VIN Hot-Plug with NTC/Battery

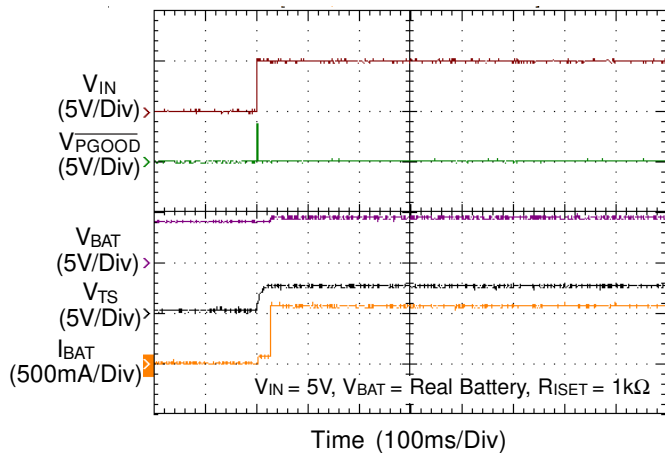

VIN Over Voltage Protection

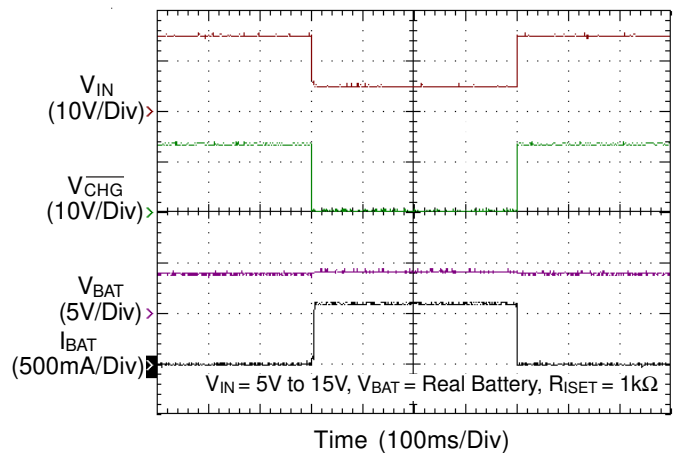

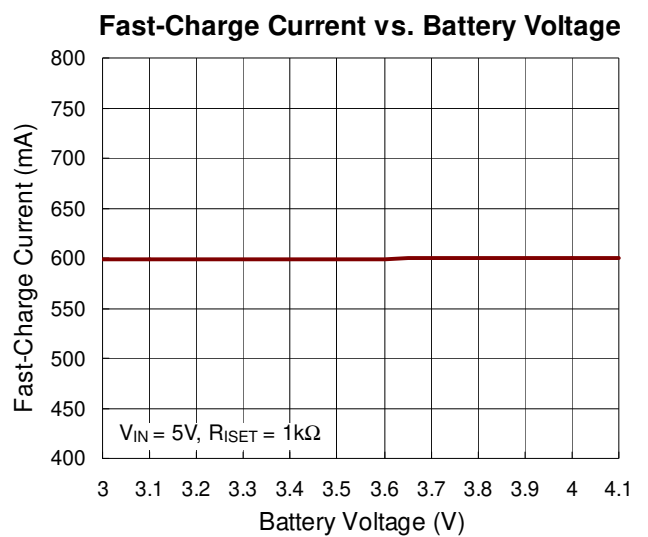
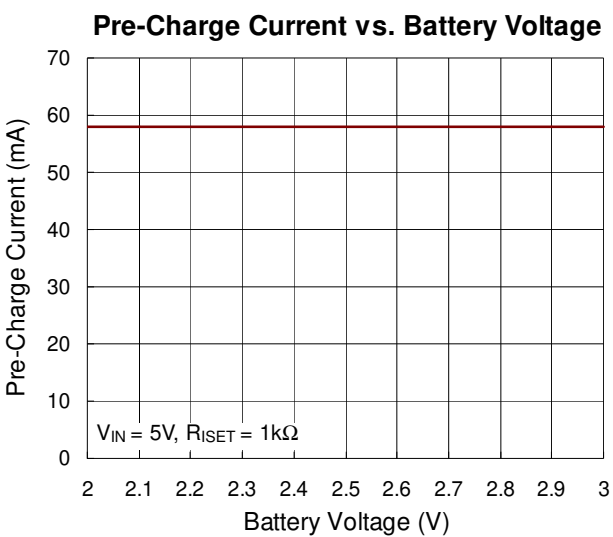
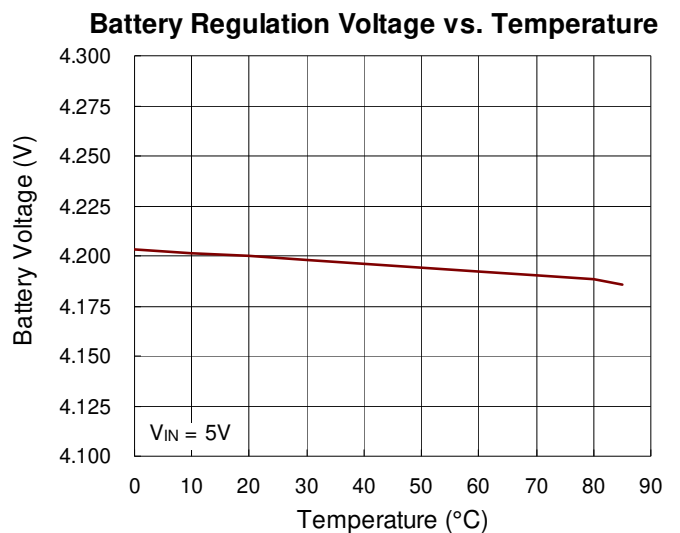
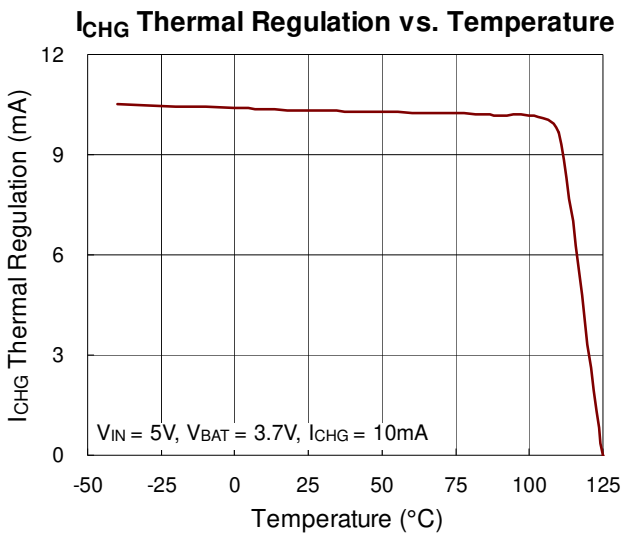
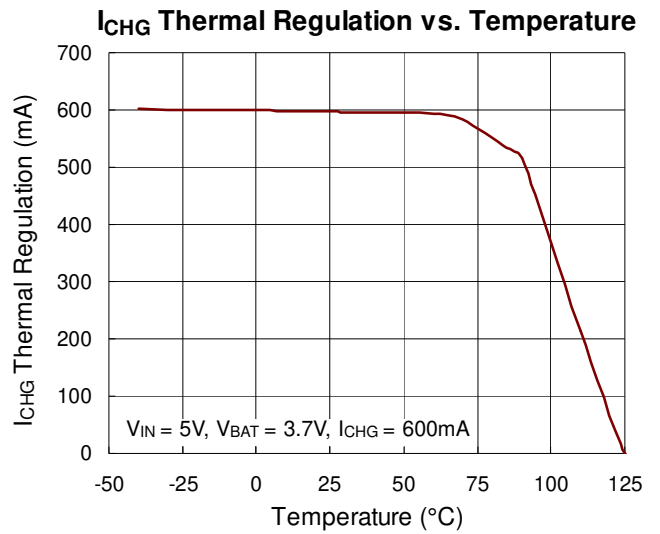
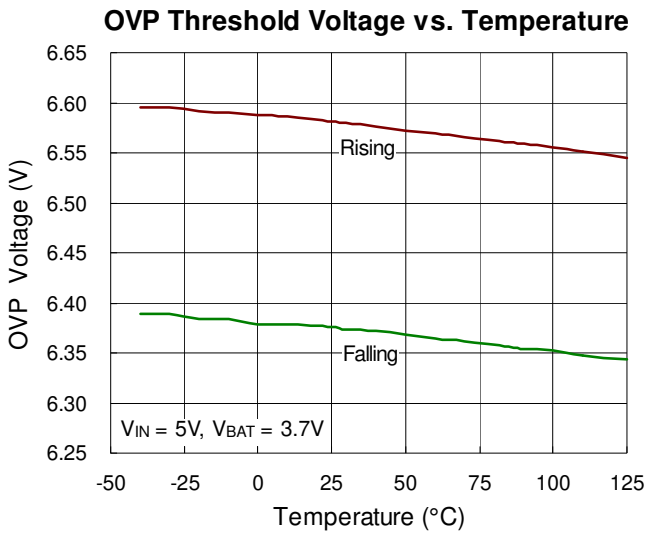

Application Information

The RT9527 is a fully integrated low cost single-cell Li-ion battery charger ideal for portable applications. The internal thermal feedback circuitry regulates the die temperature to optimize the charge rate at all ambient temperatures. The RT9527 features 20V maximum rating voltages for VIN. Other features include under voltage protection and over voltage protection for AC adapter supply, as well as a charging time monitor.

Pre-Charge Mode

When the output voltage becomes lower than 2.8V, the charging current reduces to 10% of the setting current to protect the battery life time as shown below :

$$I_{CHG_P} = K_{CHG_P} / R_{ISET}$$

where K_{CHG_P} is the pre-charge current factor.

Fast-Charge Mode

When the output voltage becomes higher than 3V, the charging current will be equal to the setting current which is determined by R_{ISET} .

$$I_{CHG_F} = K_{CHG_Fx} / R_{ISET}$$

where K_{CHG_Fx} is the fast-charge current factor.

Constant Voltage Mode

As the output voltage is near 4.2V, the charging current will be reduced to maintain the output voltage. The charger remains active and maintains the output voltage at 4.2V in order to keep the battery in a full charge state.

Recharge Mode

When the chip is in charge termination mode, the charging current goes down to zero and the battery voltage drops to 4.1V. After a deglitch time of 100ms (typ.), the battery begins recharging. However, when recharge happens, the indicator \overline{CHG} remains in logic high.

\overline{CHG} Indicator

The \overline{CHG} pin is an open-drain output. \overline{CHG} will assert low when the charger starts to charge the battery and become high impedance when the charge termination current is reached. The \overline{CHG} signal is interfaced either with a microprocessor GPIO or an LED for indication.

Charge State	\overline{CHG} Output
Charging	Low (for first charger cycle)
Charging suspended by thermal loop	
Safety timers expired	High impedance
TS fault	Low (for first charger cycle)
Charging done	High impedance
Recharging after termination	
No valid input power	

\overline{PGOOD} Indicator

This open-drain output pin is used to indicate the input voltage status. \overline{PGOOD} output asserts low when

1. $V_{IN} > V_{UVLO}$
2. $(V_{IN} - V_{BAT}) > V_{OS_H}$
3. $V_{IN} < V_{OVP}$

It can be used to drive an LED or communicate to the host processor. Note that “LOW” indicates the open-drain transistor is turned on and the LED is bright.

Charge Termination

When the charge current is lower than the charge termination current ratio ($10\% = I_{CHG} / I_{CHG_F}$) for $V_{BAT} > 4.1V$ and the time is larger than the deglitch time (25ms), \overline{CHG} transits from low to high. \overline{CHG} will be latched high unless the power is re-toggled.

ISET Pin Short Protection

After VIN power plugs in, RT9527 will detect that ISET pin is short to ground or not. If R_{ISET} is smaller than R_{SHORT} , RT9527 regard that ISET pin is short to ground. Then, RT9527 will disable charge function until VIN power reset.

If R_{ISET} is larger than R_{SHORT} , RT9527 will charge. If RT9527 begins charge status and ISET pin is short to ground, thermal regulation will work to limit junction temperature around 125°C.

Battery Connect Reverse

If battery is connected reversely, it causes that the voltage of BAT pin is negative. RT9527 will disable charger function until battery voltage is normal.

Temperature Regulation

In order to maximize charge rate, the RT9527 features a junction temperature regulation loop. If the power dissipation of the IC results in junction temperature greater than the thermal regulation threshold (125°C), the RT9527 will cut back on the charge current and disconnect the battery in order to maintain thermal regulation at around 125°C. This operation continues until the junction temperature falls below the thermal regulation threshold (125°C) by the hysteresis level. This feature prevents the maximum power dissipation from exceeding typical design conditions.

Sleep mode

The RT9527 enters sleep mode if both the AC and USB ports are removed from the input. This feature prevents draining the battery during the absence of an input supply.

Battery Pack Temperature Monitoring

The RT9527 features an external battery pack temperature monitoring input. The TS input connects to the NTC thermistor in the battery pack to monitor battery temperature and prevent danger over temperature conditions. If at any time the voltage at TS falls outside of the operating range, charging will be suspended. The timers maintain their values but suspend counting. When charging is suspended due to a battery pack temperature fault, the CHG pin remains low and continues to indicate charging.

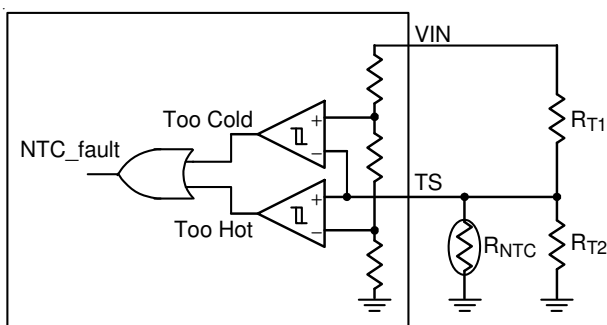

$$R_{T2} = \frac{310R_{TC}R_{TH}}{117R_{TC} - 427R_{TH}}$$

$$R_{T1} = \frac{7R_{TH}R_{T2}}{3(R_{TH} + R_{T2})}$$

Time Fault

The Fast-Charge Fault Time is set according to the following equations :

Fast-Charge Fault Time : $t_{FCHG} = 14400 \times C_{TIMER} \text{ (s)}$

Pre-Charge Fault Time : $t_{PCHG} = 1 / 8 \times t_{FCHG} \text{ (s)}$

where the C_{TIMER} unit is in μF .

When time fault happens, the charger cycle will be turned off and the CHG pin will become high impedance.

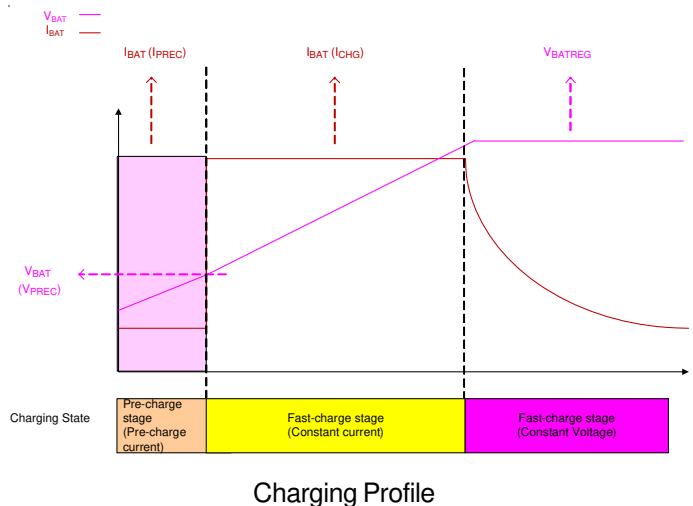

Thermal Considerations

For continuous operation, do not exceed absolute maximum junction temperature. The maximum power dissipation depends on the thermal resistance of the IC package, PCB layout, rate of surrounding airflow, and difference between junction and ambient temperature. The maximum power dissipation can be calculated by the following formula :

$$P_{D(MAX)} = (T_{J(MAX)} - T_A) / \theta_{JA}$$

where $T_{J(MAX)}$ is the maximum junction temperature, T_A is the ambient temperature, and θ_{JA} is the junction to ambient thermal resistance.

For recommended operating condition specifications, the maximum junction temperature is 125°C. The junction to ambient thermal resistance, θ_{JA} , is layout dependent. For

WDFN-8L 2x2 package, the thermal resistance, θ_{JA} , is $45.5^{\circ}\text{C}/\text{W}$ on a standard JEDEC 51-7 four-layer thermal test board. The maximum power dissipation at $T_A = 25^{\circ}\text{C}$ can be calculated by the following formula :

$$P_{D(\text{MAX})} = (125^{\circ}\text{C} - 25^{\circ}\text{C}) / (45.5^{\circ}\text{C}/\text{W}) = 2.19\text{W for WDFN-8L 2x2 package}$$

The maximum power dissipation depends on the operating ambient temperature for fixed $T_{J(\text{MAX})}$ and thermal resistance, θ_{JA} . The derating curve in Figure 1 allows the designer to see the effect of rising ambient temperature on the maximum power dissipation.

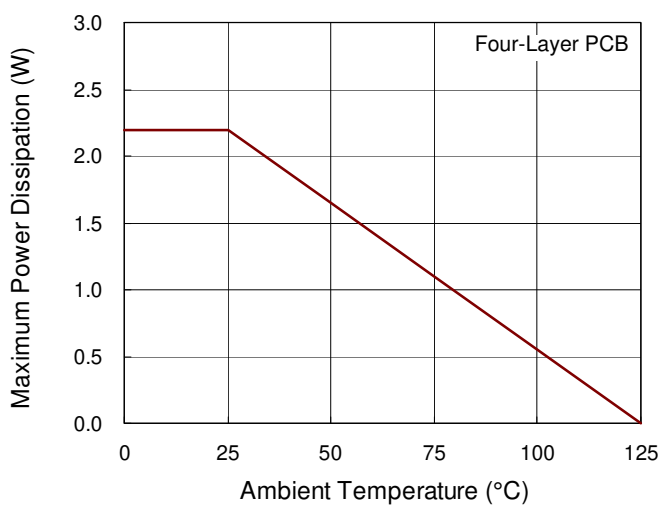

Figure 1. Derating Curve of Maximum Power Dissipation

Layout Considerations

The RT9527 is a fully integrated low cost single cell Li-Ion battery charger ideal for portable applications. Careful PCB layout is necessary. For best performance, place all peripheral components as close to the IC as possible. A short connection is highly recommended. The following guidelines must be strictly followed when designing a PCB layout for the RT9527.

- ▶ Input and output capacitor should be placed close to IC and connected to ground plane. The trace of input in the PCB should be placed far away from the sensitive devices and shielded by the ground.
- ▶ The GND and exposed pad should be connected to a strong ground plane for heat sinking and noise protection.

- ▶ The connection of R_{ISET} should be isolated from other noisy traces. A short wire is recommended to prevent EMI and noise coupling.

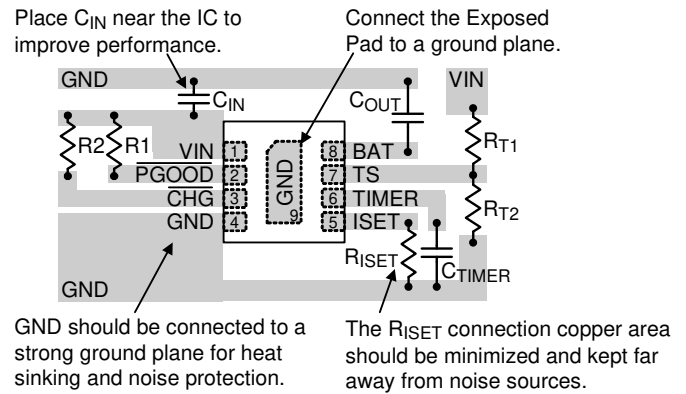

Figure 2. PCB Layout Guide

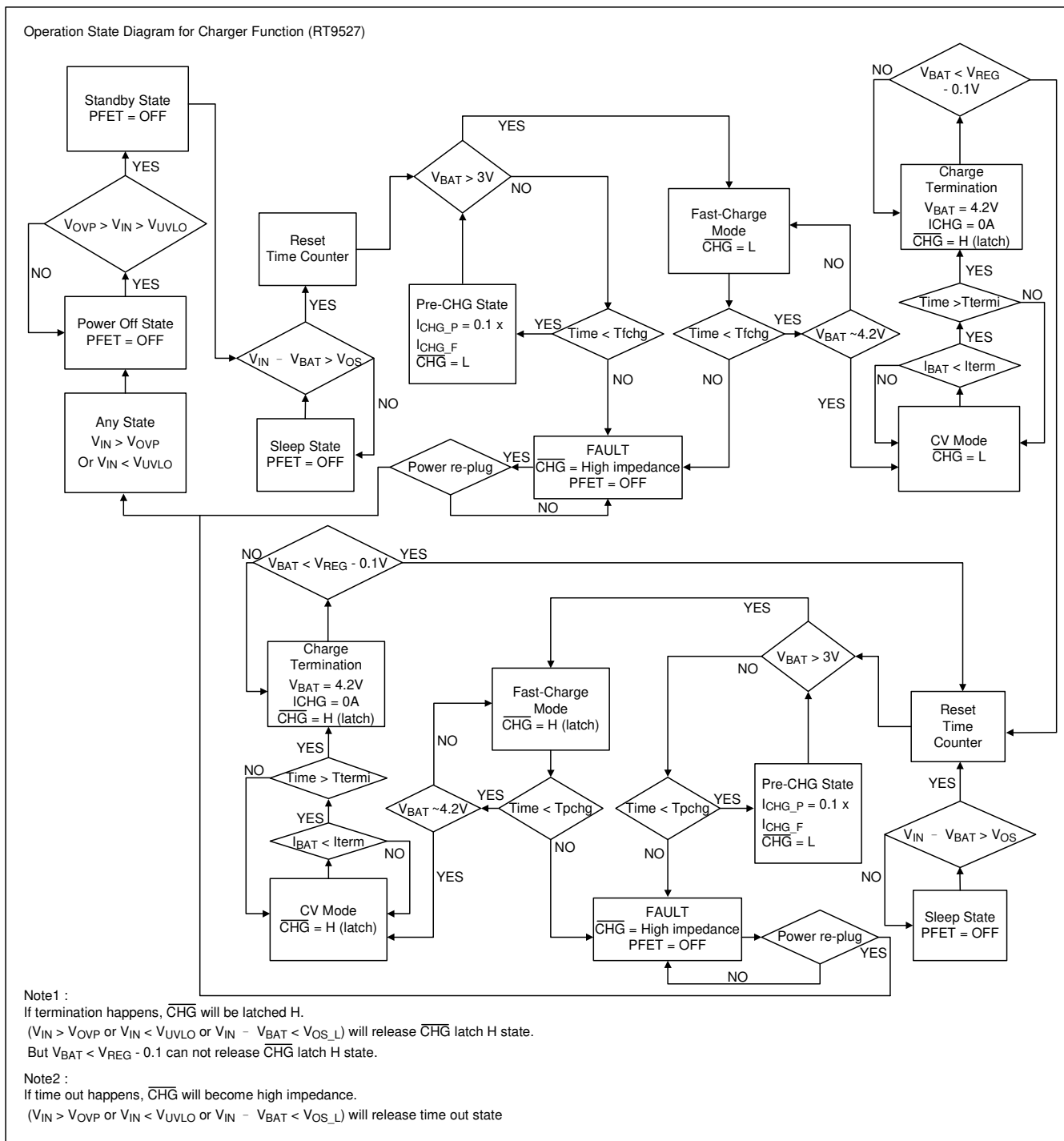
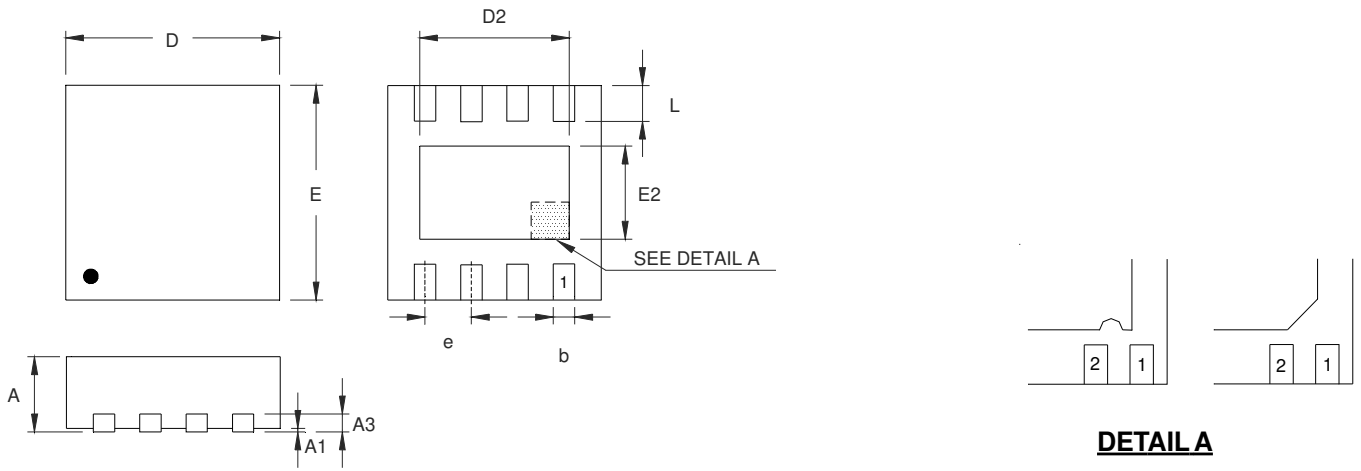

Figure 3. Operation State Diagram for Charging

Outline Dimension



DETAIL A

Pin #1 ID and Tie Bar Mark Options

Note : The configuration of the Pin #1 identifier is optional, but must be located within the zone indicated.

Symbol	Dimensions In Millimeters		Dimensions In Inches	
	Min	Max	Min	Max
A	0.700	0.800	0.028	0.031
A1	0.000	0.050	0.000	0.002
A3	0.175	0.250	0.007	0.010
b	0.200	0.300	0.008	0.012
D	1.950	2.050	0.077	0.081
D2	1.000	1.250	0.039	0.049
E	1.950	2.050	0.077	0.081
E2	0.400	0.650	0.016	0.026
e	0.500		0.020	
L	0.300	0.400	0.012	0.016

W-Type 8L DFN 2x2 Package

Richtek Technology Corporation

14F, No. 8, Tai Yuen 1st Street, Chupei City
 Hsinchu, Taiwan, R.O.C.
 Tel: (8863)5526789

Richtek products are sold by description only. Richtek reserves the right to change the circuitry and/or specifications without notice at any time. Customers should obtain the latest relevant information and data sheets before placing orders and should verify that such information is current and complete. Richtek cannot assume responsibility for use of any circuitry other than circuitry entirely embodied in a Richtek product. Information furnished by Richtek is believed to be accurate and reliable. However, no responsibility is assumed by Richtek or its subsidiaries for its use; nor for any infringements of patents or other rights of third parties which may result from its use. No license is granted by implication or otherwise under any patent or patent rights of Richtek or its subsidiaries.