

REVISIONS				
P.	LTN.	DESCRIPTION	DATE	APVD.
J1		REVISED PER ECR-15-012743	24SEP2015	J.T. W.H.

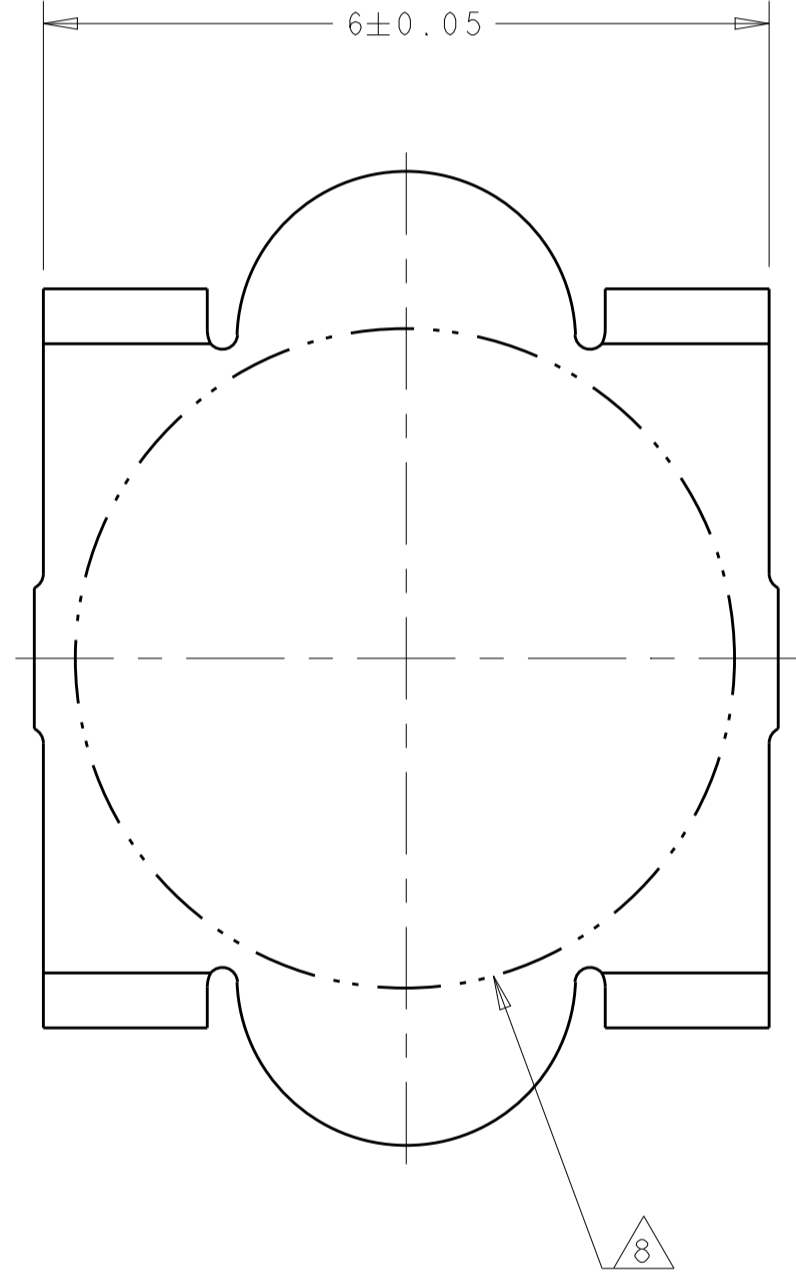

VACUUM COVER

- 1 HOUSING MATERIAL: HIGH TEMPERATURE THERMOPLASTIC, COLOR: BLACK
CONTACT MATERIAL: PHOSPHOR BRONZE
- 2 CONTACT FINISH: NICKEL UNDERPLATE ALL OVER, MATING SURFACES
PLATED TO MEET PLI PERFORMANCE REQUIREMENTS OF INDUSTRY
SPECIFICATION EIA-700AAAB, SOLDER TAILS PLATED TIN-LEAD.
- 3 DATUM LOCATIONS AND BASIC DIMENSIONS TO BE ESTABLISHED BY THE
CUSTOMER. CONSULT AMP ENGINEERING WHEN PLACING MULTIPLE
CONNECTORS ON A PC BOARD.
- 4. PACKAGED IN TAPE ON REEL PER EIA-481.
- 5. VACUUM COVER DESIGNED FOR 4mm DIA. NOZZLE. COVER TO BE REMOVED
AFTER SOLDERING. VACUUM COVER OMITTED FROM SOME VIEWS FOR
DIMENSIONAL CLARITY.
- 6. SHORTER SOLDER LANDS MAY BE USED PER EIA 700AAAB, HOWEVER 2.4
LENGTH ASSURES OPTIMUM SOLDER FILLET REGARDLESS OF MANUFACTURER
OF CONNECTOR.
- 7. REFERRED TO AS DIM H = 7.30±0.1 IN EIA 700AAAB SPECIFICATION.
- 8. 5.5 MIN DIA TARGET AREA FOR VACUUM PICK-UP.
- 9. CONTACT FINISH: 0.002 MINIMUM BRIGHT TIN-LEAD (93-7)
ON SOLDER AREA, 0.00127 MINIMUM GOLD ON MATING AREA,
BOTH OVER 0.00127 MINIMUM NICKEL ON ENTIRE CONTACT.

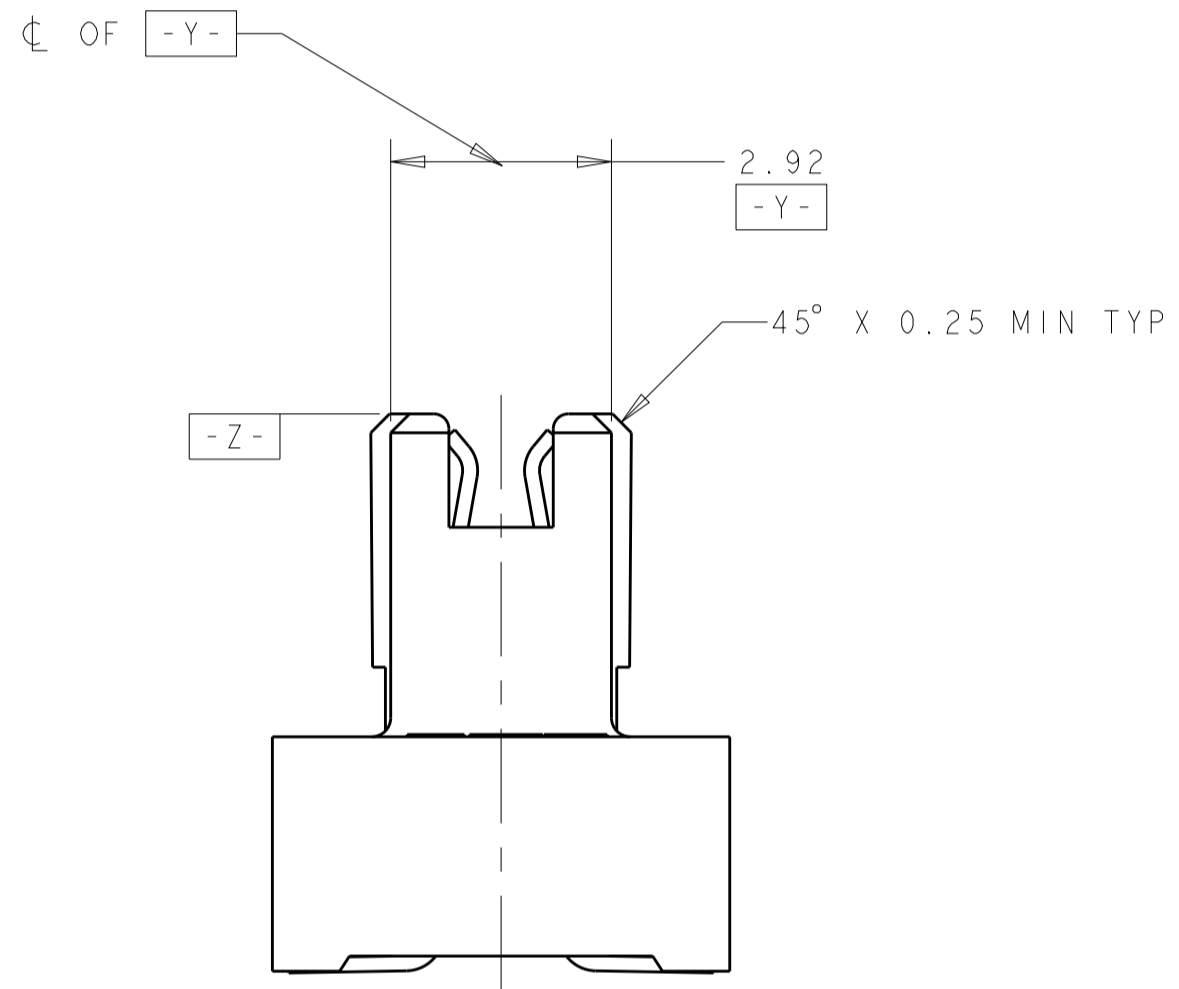
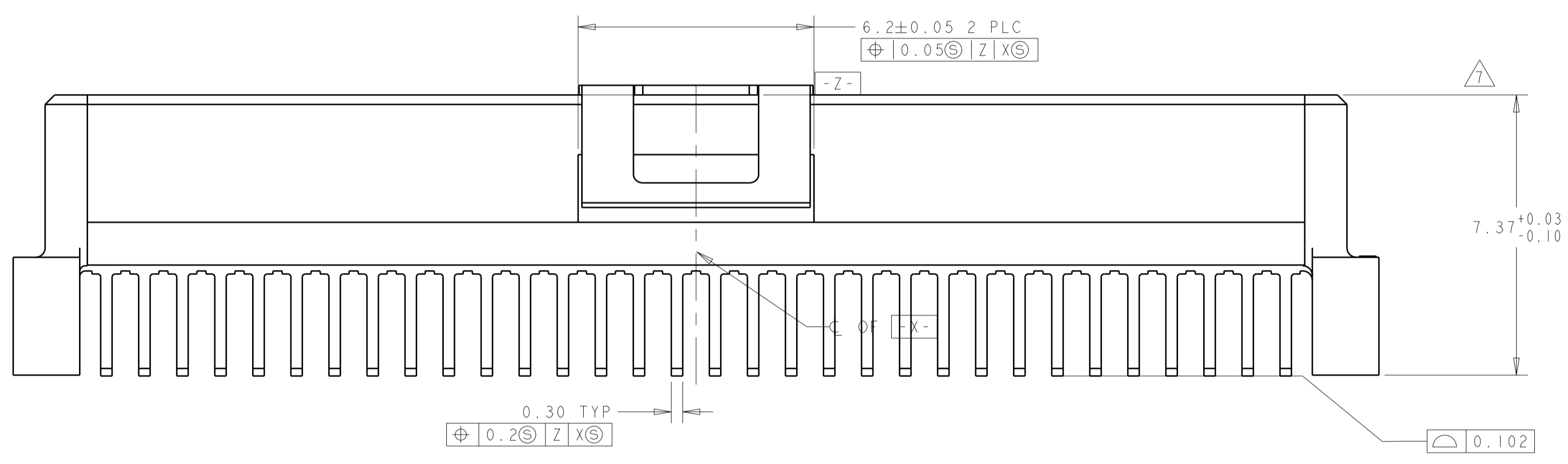
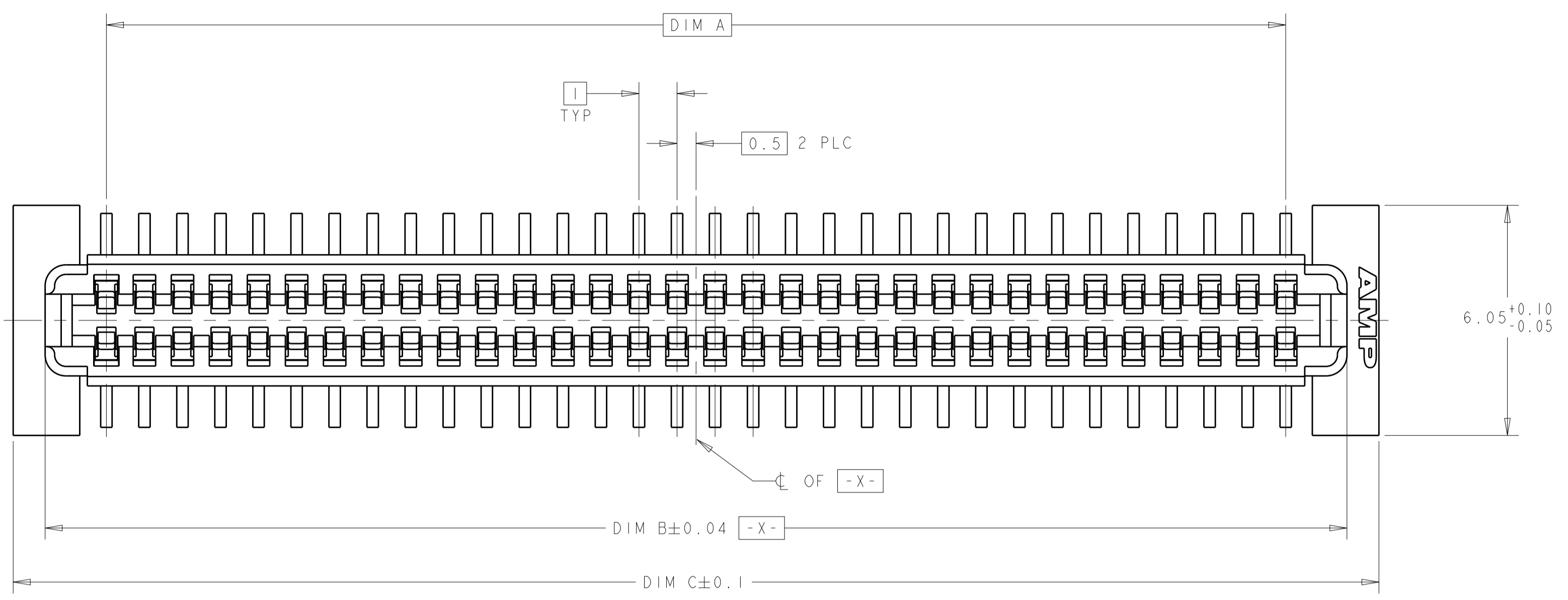
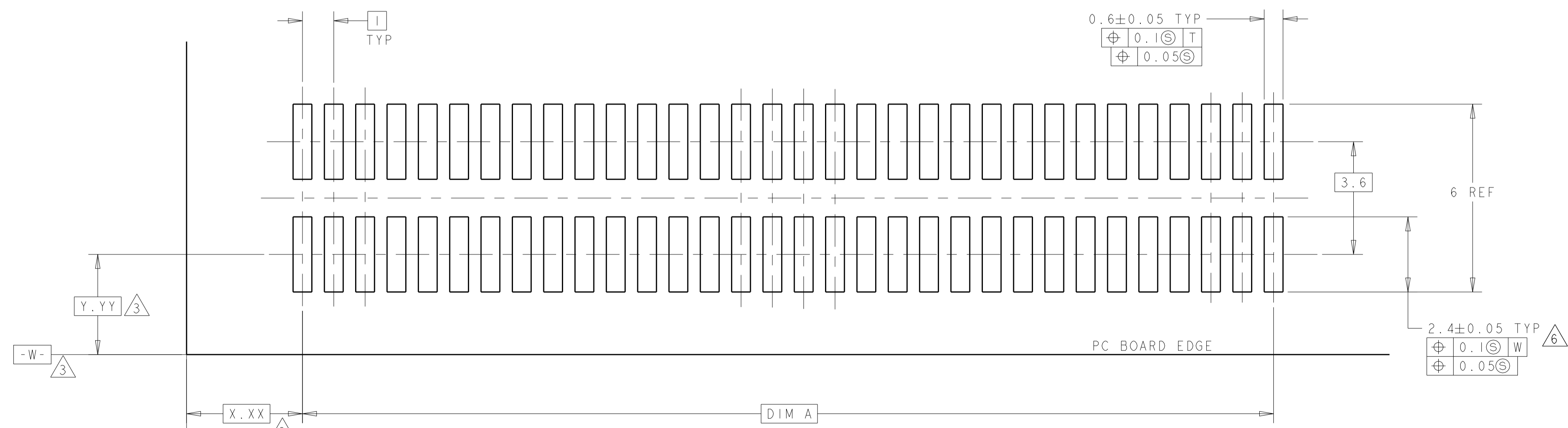

RECOMMENDED PC BOARD LAYOUT

FINISH	DIM C	DIM B	DIM A	MATING CONNECTOR	STACK HGTS	POS	PART NO
9	45.9	44.22	41	120534-2	12	84	1-120529-2
9	45.9	44.22	41	120533-2	11	84	1-120529-2
9	35.9	34.22	31	120534-1	12	64	1-120529-1
9	35.9	34.22	31	120533-1	11	64	1-120529-1
2	45.9	44.22	41	120534-2	12	84	120529-2
2	45.9	44.22	41	120533-2	11	84	120529-2
2	35.9	34.22	31	120534-1	12	64	120529-1
2	35.9	34.22	31	120533-1	11	64	120529-1

THIS DRAWING IS A CONTROLLED DOCUMENT. DIMENSIONS: mm. TOLERANCES UNLESS OTHERWISE SPECIFIED: 0 PLC ±, 1 PLC ±.03, 2 PLC ±.03, 3 PLC ±.03, 4 PLC ±.03, ANGLES 40°-1°.

DATE: 27/15/97. DRAWN: J. REED. CHECKED: L. VO. PRODUCT SPEC: 502-1079. APPLICATION SPEC: 114-25045. WEIGHT: -.

SCALE: 10:1. SHEET: 1 OF 1. REV: J1.

STE TE Connectivity
RECEPTACLE ASSEMBLY, W/ COVER, 1.0mm FH (IEEE1386) CONNECTOR