

SECTION D-D

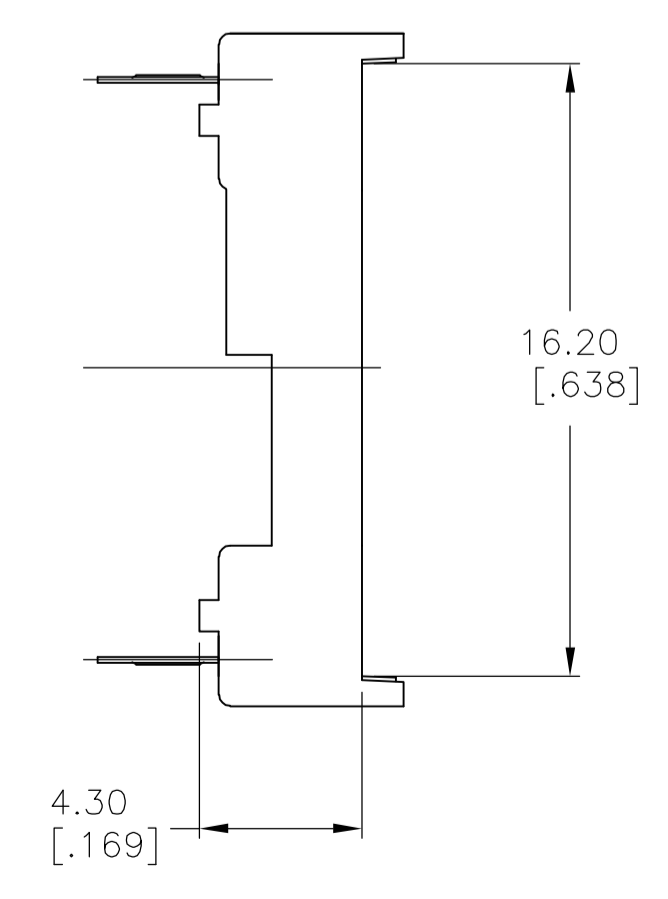
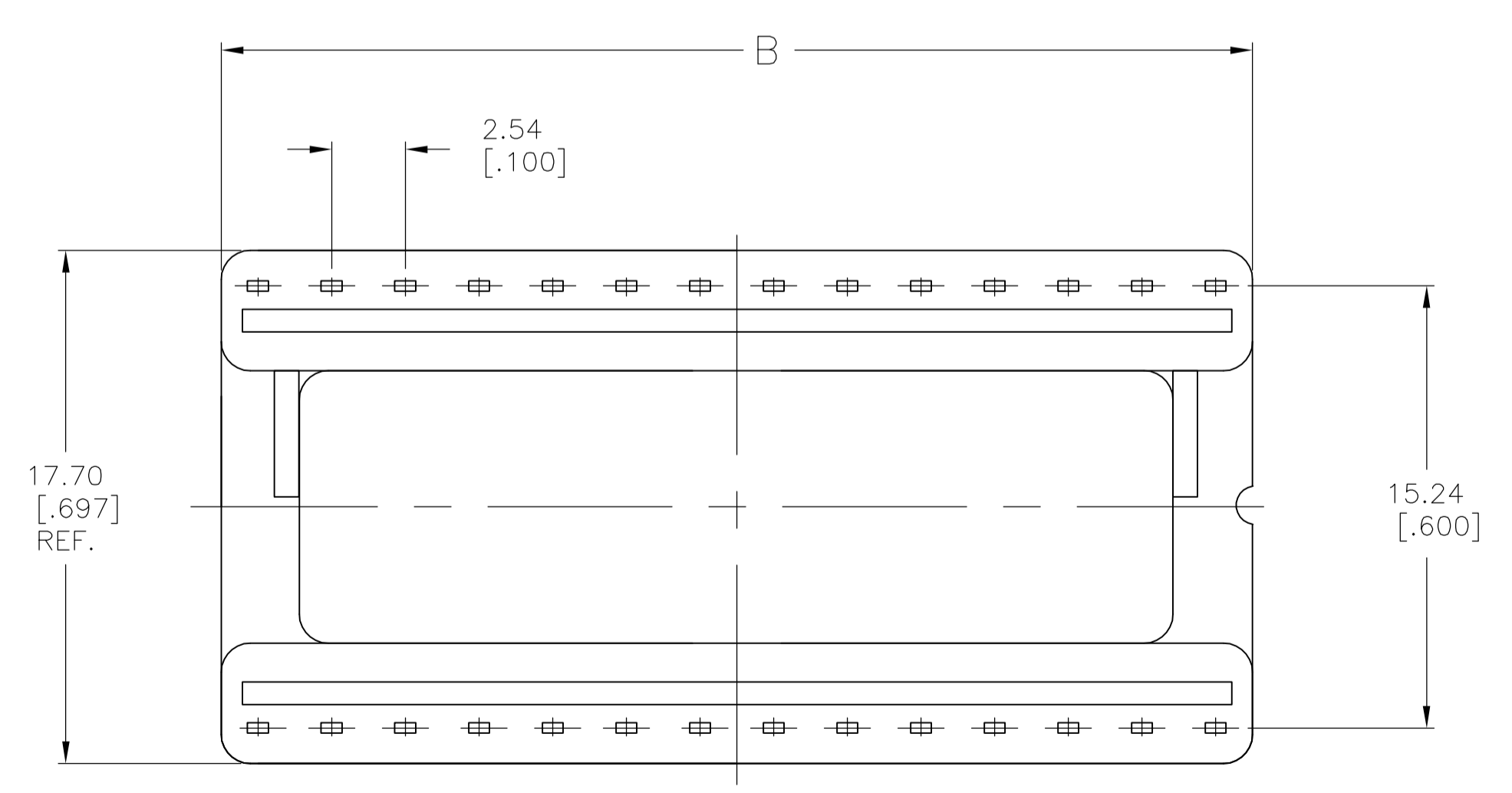
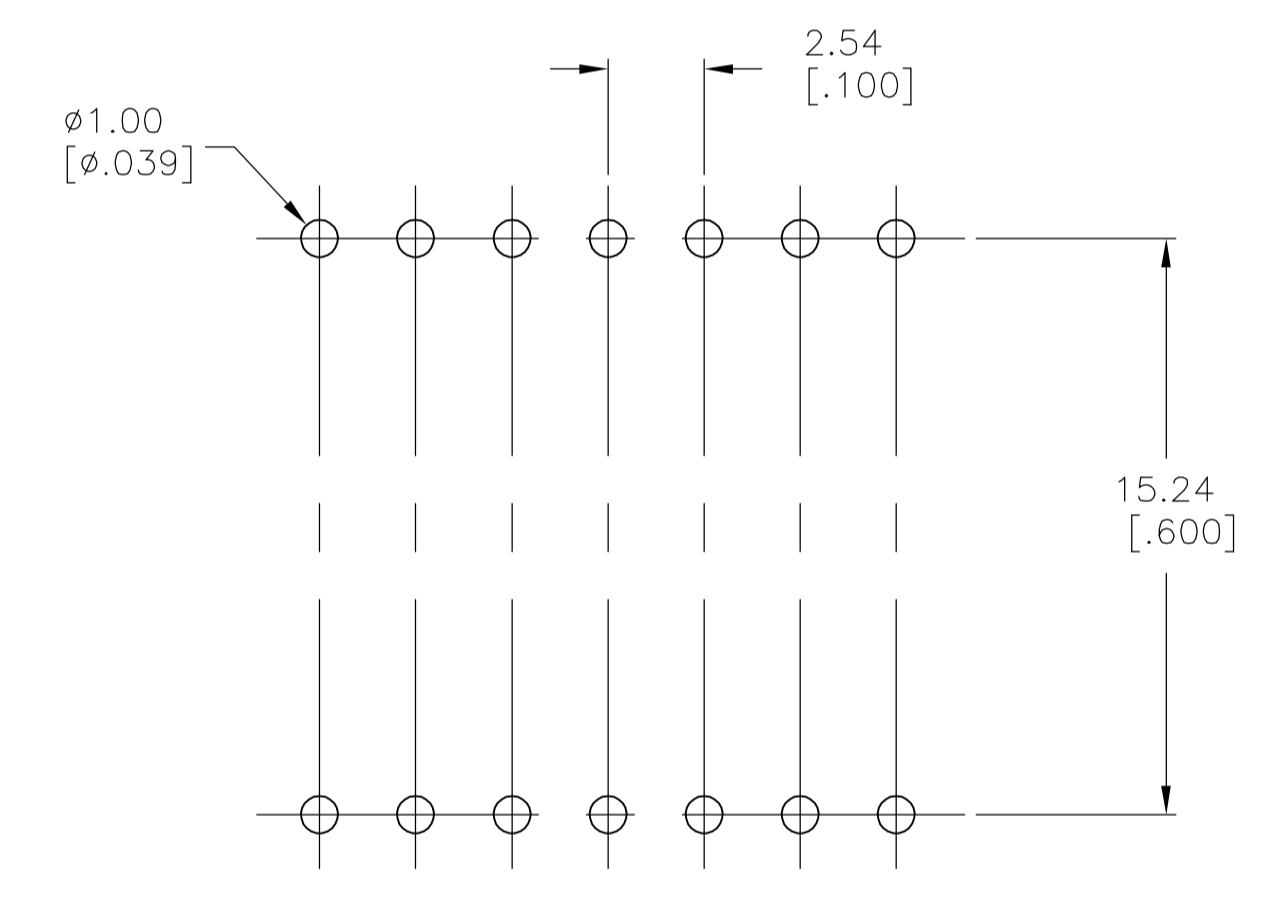
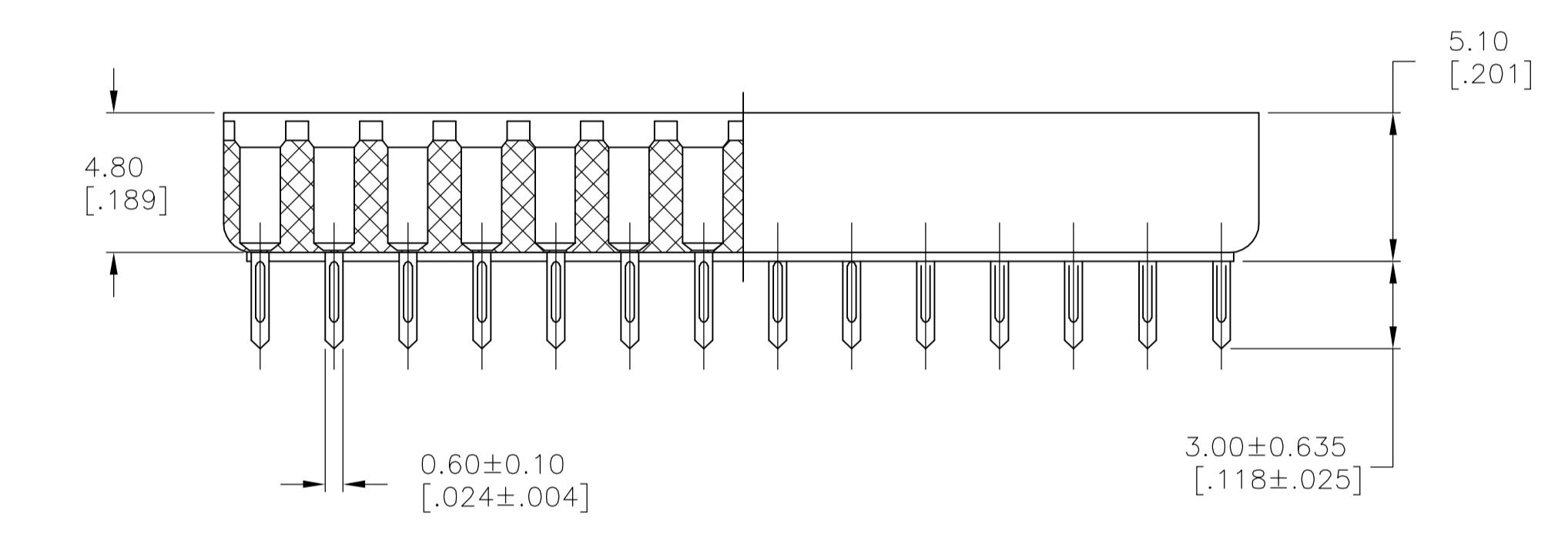

NOTE:-

- 1 MATERIAL:  
HOUSING: 30% GLASS FILLED PBT, THERMOPLASTIC, BLACK.  
CONTACT: PHOS BRONZE
- 2 FINISH: CONTACT PLATING: TIN-LEAD (60u INCHES MIN.)  
SOLDERABILITY :95% COVERAGE MIN.;  
TEST TEMPERATURE=230°C±5°C  
TEST TIME = 5±5 SECONDS.
- 3. MECHANICAL SPECS:  
DURABILITY: 50 CYCLES MIN.  
INSERTION FORCE:300 GRAMS MAX.  
WITHDRAWAL FORCE: 20 GRAMS MIN.  
CONTACT RETENTION: 500 GRAMS MIN.  
ACCEPTS: 0.20-0.30 [.008-.012] LEADS
- 4. ELECTRICAL SPECS:  
VOLTAGE RATING: 250V AC,DC  
CONTACT RESISTANCE: 20 MILLOHMS MAX.  
CURRENT RATING: 1 AMPERE AC,DC  
INSULATION RESISTANCE: 1000 MEGOHMS MIN.  
DIELECTRIC WITHSTANDING VOLTAGE: AC 1000 V MIN.
- 5. OPERATING TEMPERATURE: -40°C TO +105°C
- 6 AMP LOGO
- 7 FINISH: CONTACT PLATING TIN (LEAD FREE); 60 UIN MIN. OVER 30 UIN NI  
SOLDERABILITY :95% COVERAGE MIN.;  
TEST TEMPERATURE=260°±5°C;  
TEST TIME = 5±5 SECONDS.

△	24	25.10 [0.988]	27.94 [1.100]	30.48 [1.200]	1-390263-7
△	48	55.52 [2.19]	58.42 [2.300]	60.96 [2.400]	1-390263-6
△	42	47.90 [1.89]	50.08 [1.97]	53.34 [2.100]	1-390263-5
△	40	45.36 [1.79]	48.26 [1.900]	50.80 [2.000]	1-390263-4
△	32	35.20 [1.39]	38.10 [1.500]	40.64 [1.600]	1-390263-2
△	28	30.12 [1.19]	33.02 [1.300]	35.56 [1.400]	1-390263-1
△	24	25.10 [0.988]	27.94 [1.100]	30.48 [1.200]	390263-7
△	48	55.52 [2.19]	58.42 [2.300]	60.96 [2.400]	390263-6
△	42	47.90 [1.89]	50.08 [1.97]	53.34 [2.100]	390263-5
△	40	45.36 [1.79]	48.26 [1.900]	50.80 [2.000]	390263-4
△	32	35.20 [1.39]	38.10 [1.500]	40.64 [1.600]	390263-2
△	28	30.12 [1.19]	33.02 [1.300]	35.56 [1.400]	390263-1
FINISH	POS	C±0.15 [.004]	B±0.10 [.004]	A±0.20 [.008]	PART NO.

THIS DRAWING IS A CONTROLLED DOCUMENT.		DWN BSV 07SEP2004	Tyco Electronics Corporation Harrisburg, Pa 17105-3608	
DIMENSIONS: mm [INCHES]	TOLERANCES UNLESS OTHERWISE SPECIFIED:	CHK -	APVD K WRIGHT	NAME
0 PLC ± -	1 PLC ± -	PRODUCT SPEC	DIP SOCKET, 15.24 CENTERLINE OTC STYLE	
2 PLC ± ± 0.2[008]	3 PLC ± ± -	APPLICATION SPEC	SIZE	CAGE CODE
4 PLC ± ± -	ANGLES ± ± -	WEIGHT	A1	00779
MATERIAL 1	FINISH 2 7	CUSTOMER DRAWING	SCALE 5:1	SHEET 1 of 1