

Using the UCC27714EVM-551

User's Guide



Literature Number: SLUUB02A
July 2015–Revised September 2015

600-W Phase-Shifted Full-Bridge (PHSB) Converter Based on the 600-W PHSB UCC28950 Converter

Cautions and Warnings

CAUTION:



Caution! Do not leave EVM powered when unattended.

HOT SURFACE:



Caution Hot Surface! Contact may cause burns. Do not touch. Please take the proper precautions when operating.

HIGH VOLTAGE:



Danger High Voltage! Electric shock possible when connecting board to live wire. Board should be handled with care by a professional. For safety, use of isolated test equipment with overvoltage/overcurrent protection is highly recommended.

General Texas Instruments High Voltage Evaluation (TI HV EMV) User Safety Guidelines

Always follow TI's set-up and application instructions, including use of all interface components within their recommended electrical rated voltage and power limits. Always use electrical safety precautions to help ensure your personal safety and those working around you. Contact TI's Product Information Center <http://ti.com/support> for further information.

Save all warnings and instructions for future reference.

WARNING

Failure to follow warnings and instructions may result in personal injury, property damage or death due to electrical shock and burn hazards.

The term TI HV EVM refers to an electronic device typically provided as an open framed, unenclosed printed circuit board assembly. It is *intended strictly for use in development laboratory environments, solely for qualified professional users having training, expertise and knowledge of electrical safety risks in development and application of high voltage electrical circuits. Any other use and/or application are strictly prohibited by Texas Instruments.* If you are not suitable qualified, you should immediately stop from further use of the HV EVM.

1. Work Area Safety:

- (a) Keep work area clean and orderly.
- (b) Qualified observer(s) must be present anytime circuits are energized.
- (c) Effective barriers and signage must be present in the area where the TI HV EVM and its interface electronics are energized, indicating operation of accessible high voltages may be present, for the purpose of protecting inadvertent access.
- (d) All interface circuits, power supplies, evaluation modules, instruments, meters, scopes, and other related apparatus used in a development environment exceeding 50Vrms/75VDC must be electrically located within a protected Emergency Power Off EPO protected power strip.
- (e) Use stable and non-conductive work surface.
- (f) Use adequately insulated clamps and wires to attach measurement probes and instruments. No freehand testing whenever possible.

2. Electrical Safety:

As a precautionary measure, it is always good engineering practice to assume that the entire EVM may have fully accessible and active high voltages.

- (a) De-energize the TI HV EVM and all its inputs, outputs and electrical loads before performing any electrical or other diagnostic measurements. Revalidate that TI HV EVM power has been safely de-energized.
- (b) With the EVM confirmed de-energized, proceed with required electrical circuit configurations, wiring, measurement equipment hook-ups and other application needs, while still assuming the EVM circuit and measuring instruments are electrically live.
- (c) Once EVM readiness is complete, energize the EVM as intended.

WARNING

While the EVM is energized, never touch the EVM or its electrical circuits, as they could be at high voltages capable of causing electrical shock hazard.

3. Personal Safety

- (a) Wear personal protective equipment e.g. latex gloves or safety glasses with side shields or protect EVM in an adequate lucent plastic box with interlocks from accidental touch.

Limitation for safe use:

EVMs are not to be used as all or part of a production unit.

1 Introduction

This 600-W EVM was designed to demonstrate how the [UCC28950](#) control device, [UCC27524A](#) and [UCC27714](#) gate drivers could be used in high-efficiency applications by achieving ZVS from 50% to 100% load. To achieve this high efficiency the [UCC28950](#) was designed to drive synchronous rectifiers on the secondary side of the full-bridge converter. The [UCC28950](#) also incorporates a burst mode and DCM function to improve no-load efficiency. Please see [UCC28950](#) data sheet for details.

The [UCC27714](#) is a high-speed, high-voltage, high-side/low-side gate driver optimized for driving MOSFETs in high-frequency, switch-mode power supplies that are based on bridge-type topologies. It enables users to eliminate bulky gate-drive transformers in offline power supplies and achieve fast switching of power MOSFETs by virtue of its low propagation delay and high-peak-drive current.

2 Description

The UCC27714EVM-551 is a 600-W phase-shifted, full-bridge converter that converts a 370- V_{DC} to 410- V_{DC} input to a regulated 12-V output. This converter was designed to maintain ZVS down to 50% load.

2.1 Features

- ZVS from 50% to 100% load
- Higher Efficiency for 80-plus Applications
- Burst Mode/DCM Function (reduces no-load power dissipation to meet green mode requirements)
- Features [UCC28950](#) controller, [UCC27714](#) High-Voltage, High-Side/Low-Side Gate Driver, [UCC27524A](#) Dual-Channel Low-Side Gate Driver and CSD19506KCS MOSFETs

2.2 Typical Applications for Phase-Shifted Full Bridge

- Server, Telecom Power Supplies
- Industrial Power Systems
- High-Density Power Architectures

3 Electrical Performance Specifications

Table 1. UCC27714EVM-551 Electrical Specifications⁽¹⁾

PARAMETER	TEST CONDITIONS	MIN	TYP	MAX	UNITS
Input Characteristics					
DC input voltage range		370	390	410	V
Maximum input current	$V_{IN} = 370 V_{DC}$ to $410 V_{DC}$			2	A
Output Characteristics					
Output voltage (V_{OUT})	$V_{IN} = 370 V_{DC}$ to $410 V_{DC}$	11.4	12	12.6	V
Output current (I_{OUT})	$V_{IN} = 370 V_{DC}$ to $410 V_{DC}$			50	A
Continuous output power (P_{OUT})	$V_{IN} = 370 V_{DC}$ to $410 V_{DC}$			600	W
Load regulation	$V_{IN} = 370 V_{DC}$ to $410 V_{DC}$ $I_{OUT} = 5 A$ to $50 A$			150	mV
Line regulation	$V_{IN} = 370 V_{DC}$ to $410 V_{DC}$ $I_{OUT} = 5 A$ to $50 A$			150	mV
Output ripple voltage	$V_{IN} = 370 V_{DC}$ to $410 V_{DC}$ $I_{OUT} = 5 A$ to $50 A$			200	mV
Holdup time	V_{IN} stepped from $390 V_{DC}$ to $0 V_{DC}$ $P_{OUT} = 500 W$		17		ms
System					
Full load efficiency	$V_{IN} 370 V$ to $390 V$, $P_{OUT} = 500 W$	93%	94%		

⁽¹⁾ Operation ambient temperature full load, forced-air cooling 400 LFM at 25°C.

4 Schematic

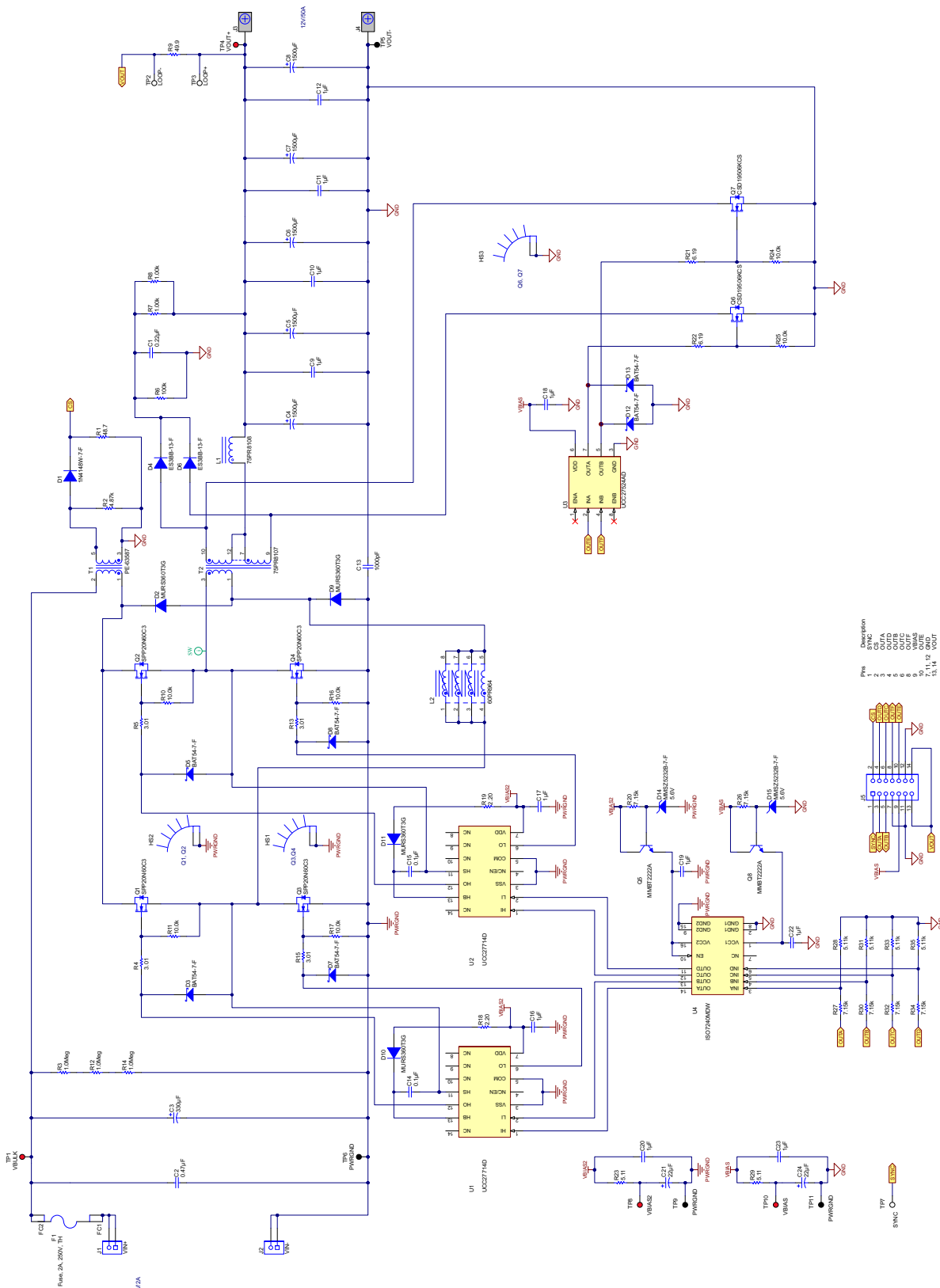

Figure 1. UCC27714EVM-551 Power Stage Schematic

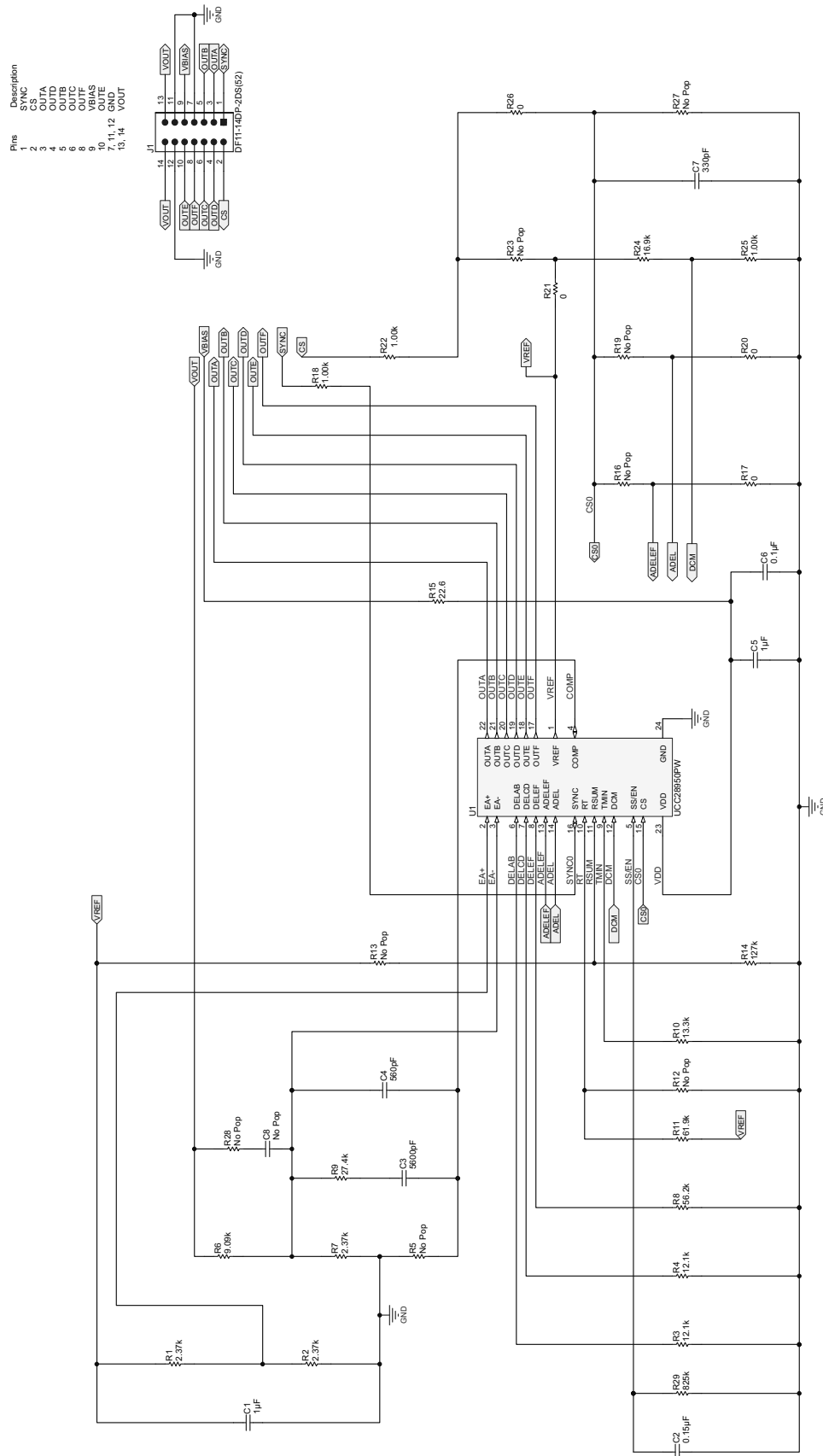

Figure 2. UCC27714EVM-551 Daughter Card Controller Schematic

5 Recommended Basic Test Equipment

Voltage Sources:

- 500- V_{DC} Source Capable of 750 W
- Two DC Power Supply Capable of 20 V

Volt Meters: 4-V Meters

Output Load: 25-V/750-W Load

Precision Shunt Resistors for Measuring Efficiency:

- $R_{SHUNT1} = 5 \text{ A}/100 \text{ mV}$
- $R_{SHUNT2} = 50 \text{ A}/50 \text{ mV}$

Fan: 400 LFM

Recommended Wire Gauge:

- 18 AWG at V_{IN} , $V_{IN} -$ to Source
- 8 AWG at V_{OUT} , $V_{OUT} -$ to Electronic/Resistive Loads

6 Recommended Test Setup

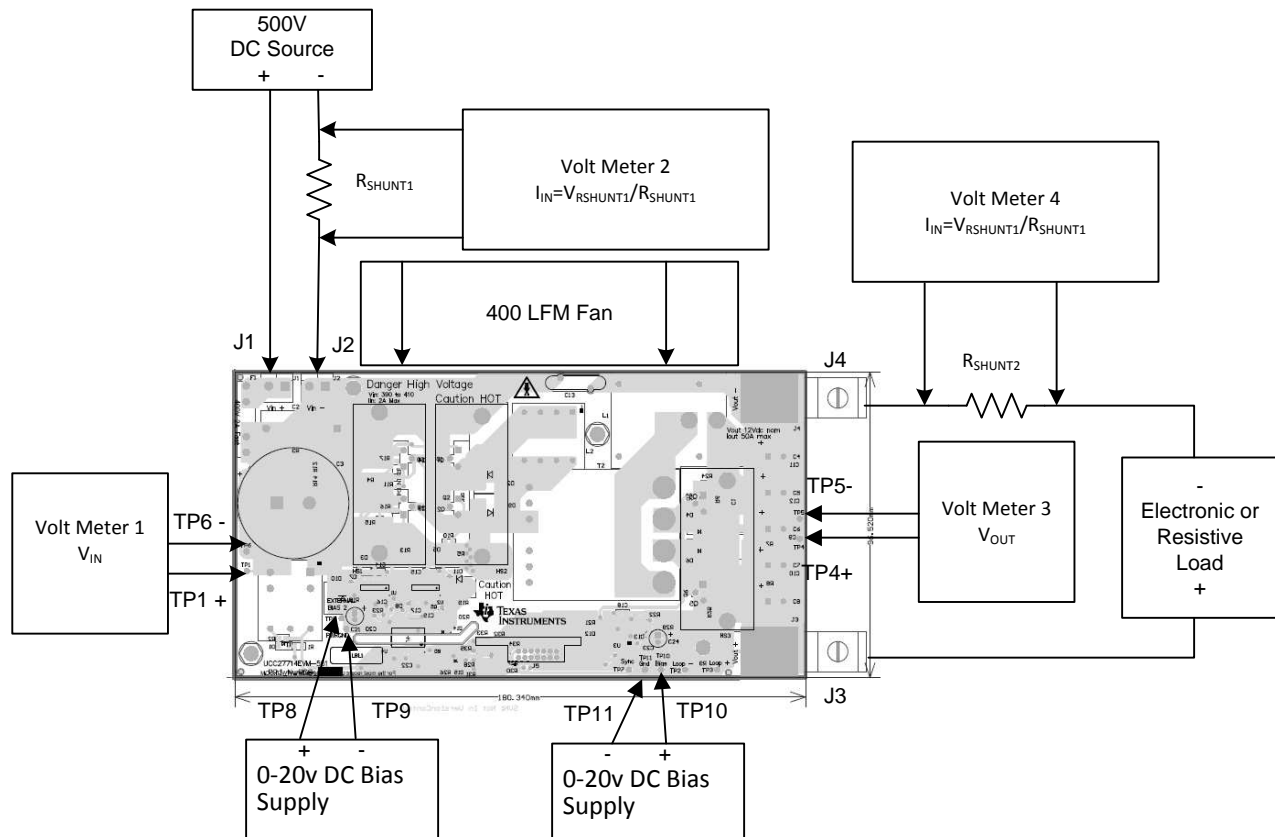

Figure 3. Test Setup to Measure Efficiency

6.1 List of Test Points

Table 2. Test Points

TEST POINTS	NAME	DESCRIPTION
TP1	VBULK	Input voltage positive (VIN+)
TP2	N/A	Voltage loop injection point 1
TP3	N/A	Voltage loop injection point 2
TP4	VOUT+	Output voltage positive
TP5	VOUT-	Output voltage negative
TP6	PWRGND	Input voltage ground (VIN-)
TP7	SYNC	Synchronization input
TP8	VBIAS2	Bias 2 positive
TP9	GND2	Bias 2 negative
TP10	VBIAS	Bias positive
TP11	GND1	Bias negative

7 Power On/Off Procedure

NOTE: It is important to follow the power up and power down procedure to ensure the EVM does not get damaged.

This EVM was designed to show the performance of the [UCC28950](#), [UCC27714](#) and [UCC27524A](#) in a phase-shifted, full-bridge and is not a standalone power supply. This EVM does not include input under voltage lockout (UVLO) circuitry that would be present in a standalone power supply.

1. The EVM was not designed to startup from 0-V input voltage. Please make sure the input voltage is in-between 370 V and 410 V before applying the bias voltages.
2. Connect test setup similar to [Figure 3](#) before applying power to the EVM.
3. Apply 370 V_{DC} to 410 V_{DC} to the input of the power converter with the 500-V_{DC} source.
4. Set the 0-V to 20-V bias power supplies to 11 V, 12 V Maximum, (This powers the [UCC28950](#) PWM Controller).
5. When powering down the unit set the 0-V to 20-V DC supply to 0 V.
6. For safety before handling the EVM make sure there are not voltages present on the EVM greater than 50 V (Volt Meter 1).

8 Test Data

8.1 Line/Load Regulation and Efficiency Test Data

Table 3. Line/Load Regulations and Efficiency Test Data

SET V_{IN}	MEASURED V_{IN}	I_{IN}	V_{OUT}	I_{OUT}	EFFICIENCY
370	370.3	0.202	12.124	5.02	81%
370	370.0	0.302	12.123	8.02	87%
370	370.2	0.351	12.123	10.02	93%
370	370.2	0.857	12.123	25.03	96%
370	369.9	1.743	12.12	50.02	94%
390	390.4	0.192	12.123	5.02	81%
390	390.4	0.288	12.123	8.03	87%
390	390.3	0.334	12.123	10.03	93%
390	390.3	0.814	12.123	25.03	96%
390	390.0	1.654	12.120	50.07	94%
410	410.1	0.184	12.123	5.02	81%
410	410.1	0.276	12.123	8.02	86%
410	410.1	0.320	12.123	10.03	93%
410	410.0	0.776	12.122	25.04	95%
410	410.0	1.575	12.12	50.07	94%

8.2 Efficiency Test Data

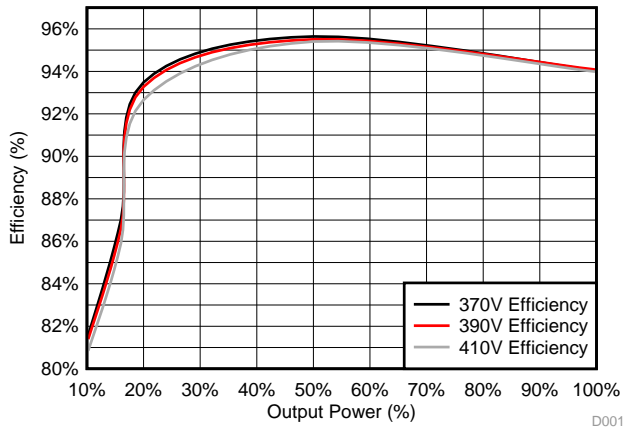

Figure 4. Efficiency 10% to 100% Load

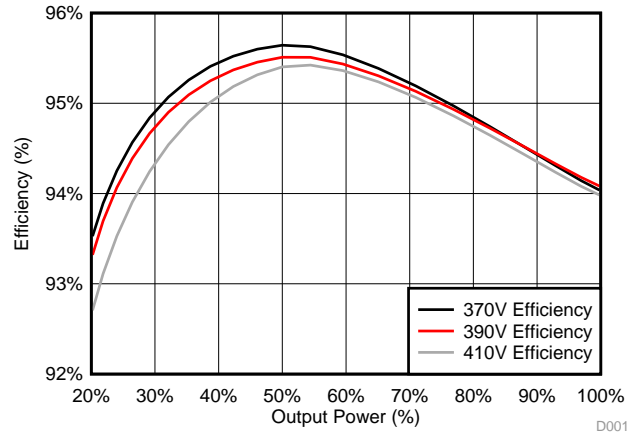

Figure 5. Efficiency 20% to 100% Load

8.3 Control Loop Gain and Phase Measurement

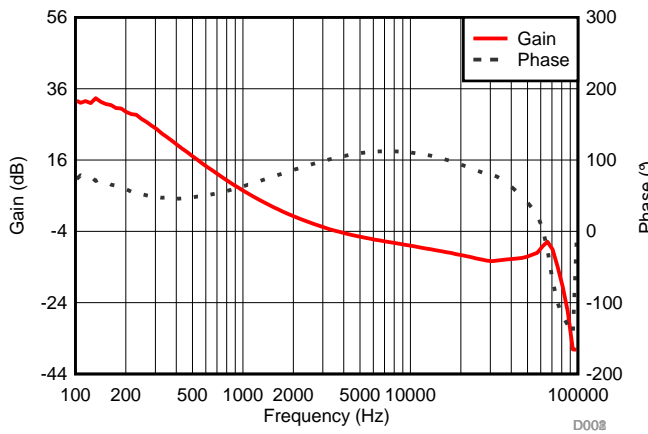

Figure 6. Loop Gain/Phase at 50 A, $f_c = 2$ kHz, PM = 90 Degrees

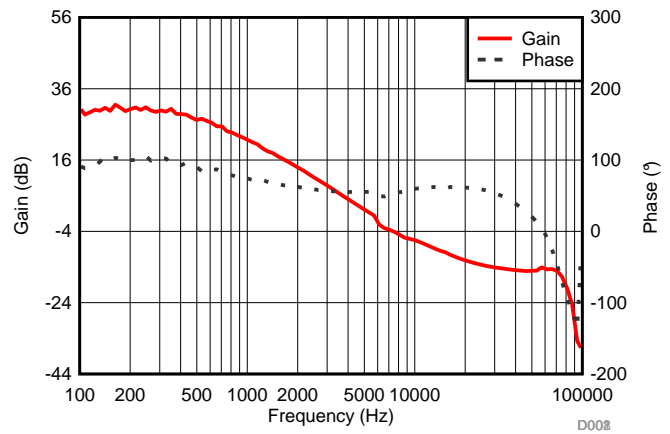

Figure 7. Loop Gain/Phase at 5 A, $f_c = 6$ kHz, PM = 45 Degrees

8.4 Transient Response

Startup CH3 = V_{OUT} .

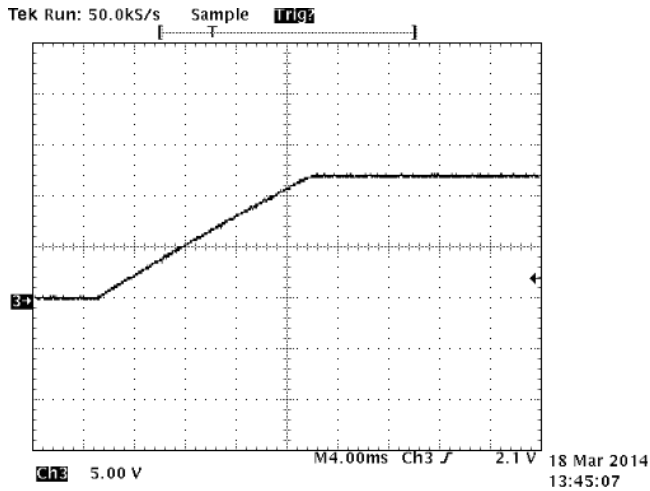

Figure 8. $V_{IN} = 390\text{ V}$, $I_{OUT} = 0\text{ A}$

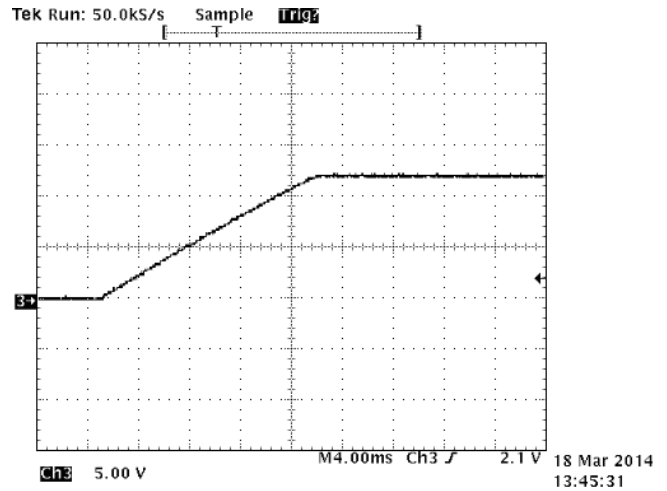

Figure 9. $V_{IN} = 390\text{ V}$, $I_{OUT} = 5\text{ A}$

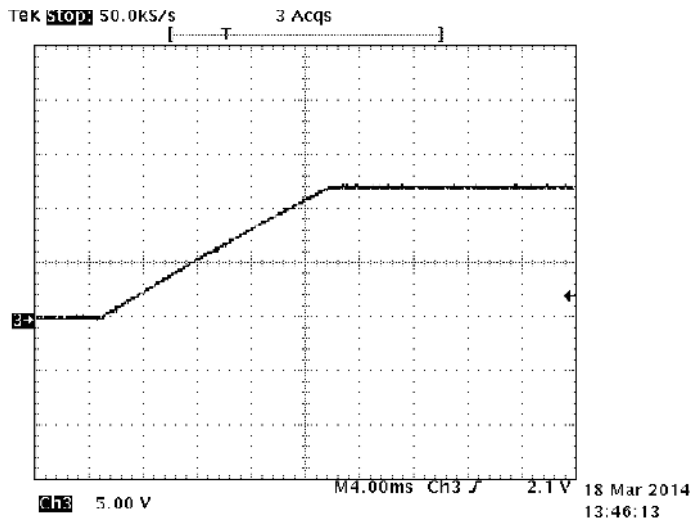

Figure 10. $V_{IN} = 390\text{ V}$, $I_{OUT} = 50\text{ A}$

8.5 Load Transient Response

CH4 = I_{OUT} , CH3 = V_{OUT} with 10- V_{DC} Offset

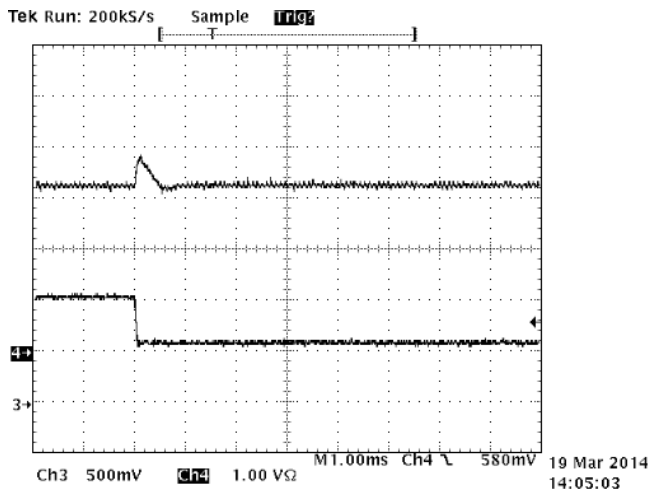

Figure 11. $V_{IN} = 390\text{ V}$, $I_{OUT} = 50\text{ A}$ to 5 A

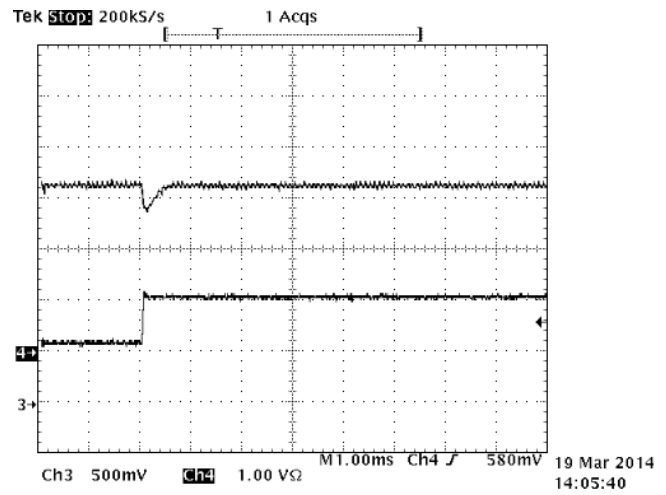

Figure 12. $V_{IN} = 390\text{ V}$, $I_{OUT} = \text{Stepped from } 5\text{ A to } 50\text{ A}$

8.6 Output Ripple Voltage

CH3 = V_{OUT}

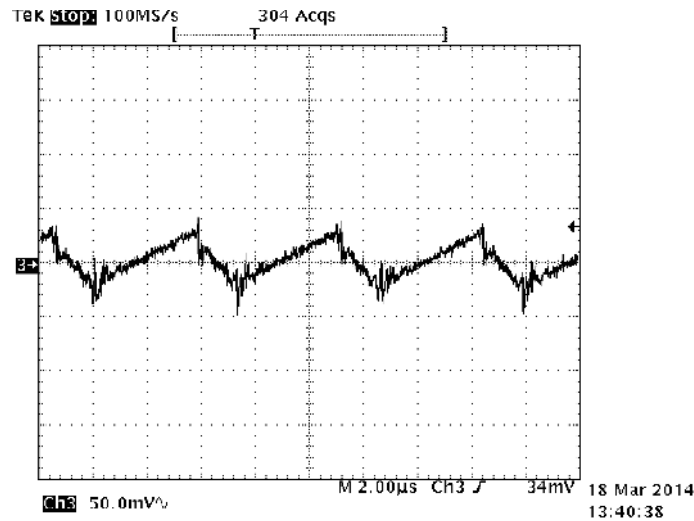

Figure 13. $V_{IN} = 390\text{ V}$, $I_{OUT} = 50\text{ A}$

8.7 Valley Switching

Loads Lower than 25 A, switch nodes valley switch

(CH1 = Q3g, CH2 = Q4g)

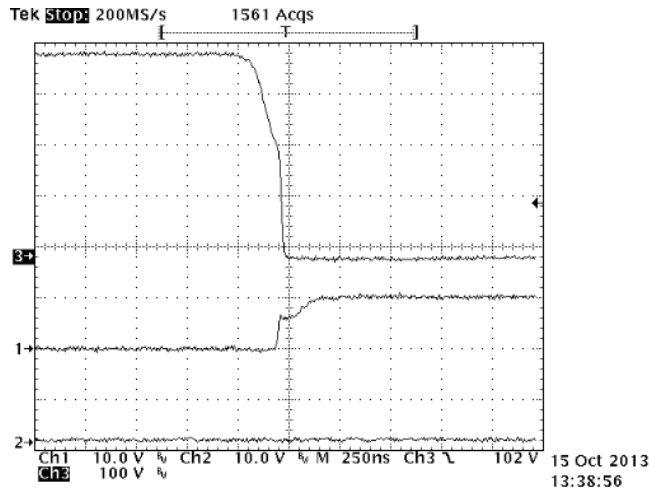

Figure 14. $V_{IN} = 390\text{ V}$, $I_{OUT} = 5\text{ A}$
($V_{IN} = 390\text{ V}$, $I_{OUT} = 5\text{ A}$ AB Valley Switching (Q3d = CH1))

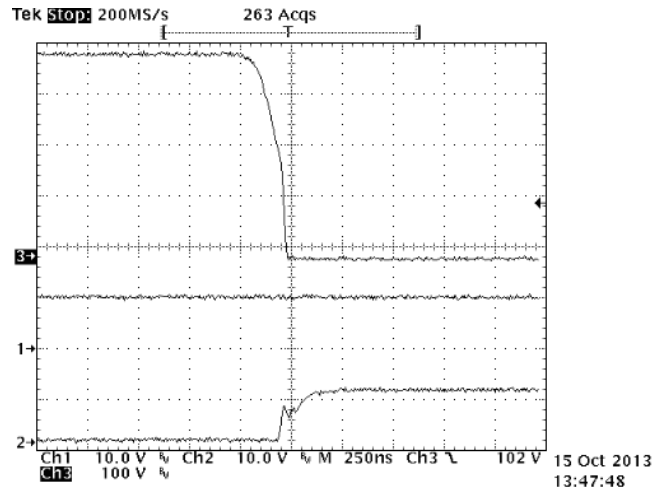

Figure 15. $V_{IN} = 390\text{ V}$, $I_{OUT} = 5\text{ A}$
($V_{IN} = 390\text{ V}$, $I_{OUT} = 5\text{ A}$ CD Valley Switching (Q4d = CH3))

Loads Greater than 25 A, the switch nodes ZVS

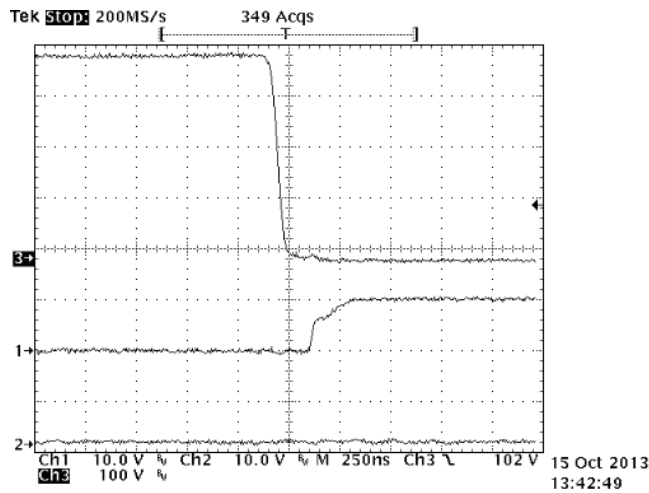

Figure 16. $V_{IN} = 390\text{ V}$, $I_{OUT} = 25\text{ A}$
($V_{IN} = 390\text{ V}$, $I_{OUT} = 25\text{ A}$ AB Valley Switching (Q3d=CH1))

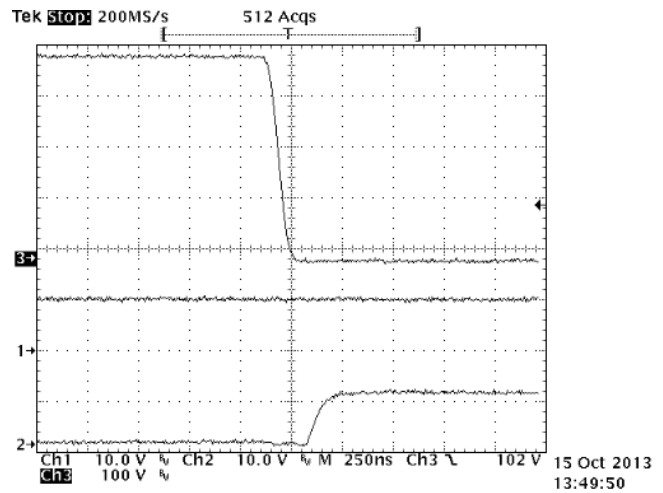

Figure 17. $V_{IN} = 390\text{ V}$, $I_{OUT} = 25\text{ A}$
($V_{IN} = 390\text{ V}$, $I_{OUT} = 25\text{ A}$ CD Valley Switching (Q4d=CH3))

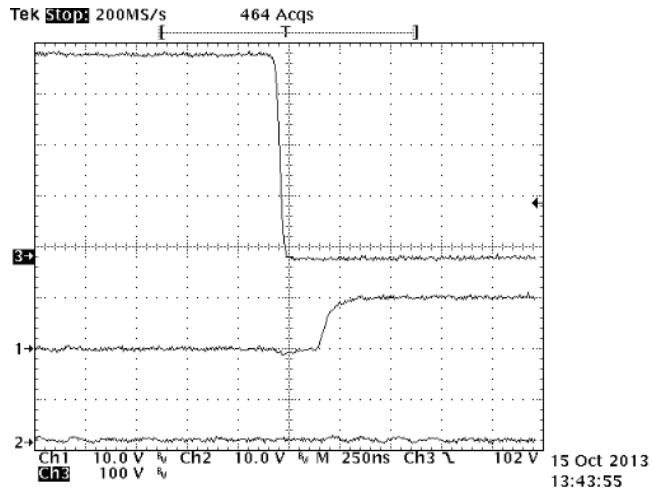

Figure 18. $V_{IN} = 390\text{ V}$, $I_{OUT} = 50\text{ A}$
 ($V_{IN} = 390\text{ V}$, $I_{OUT} = 5\text{ A}$ AB Valley Switching (Q3d=CH1))

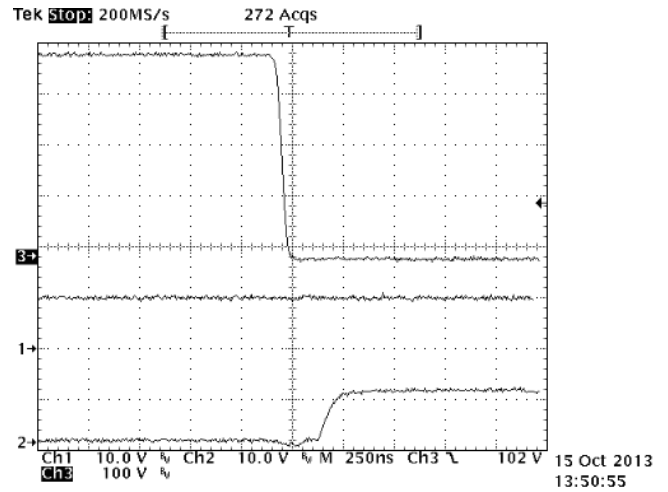

Figure 19. $V_{IN} = 390\text{ V}$, $I_{OUT} = 50\text{ A}$
 ($V_{IN} = 390\text{ V}$, $I_{OUT} = 5\text{ A}$ CD Valley Switching (Q4d = CH3))

8.8 UCC27714 Gate Drive Performance

8.8.1 LI, LO propagation delay CH1 (VDD), CH2(LO), CH3(LI)



Figure 20. LI, LO Turn-On Propagation Delay

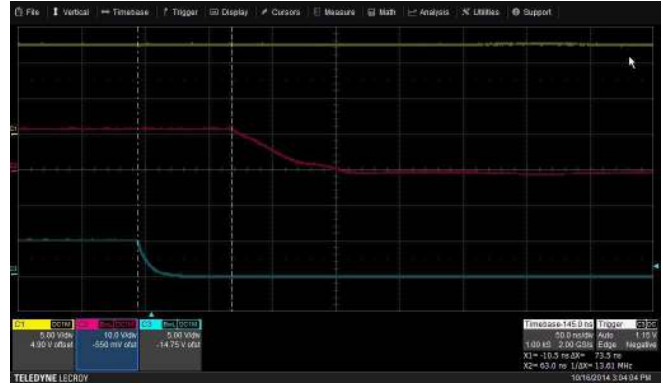

Figure 21. LI, LO Turn-Off Propagation Delay

8.8.2 First LI LO Pulse at Power Up

(CH1 (VDD), CH2(LO), CH3(LI),

Drop in VDD at first LO pulse due to charging HB capacitor)



Figure 22. VDD Drop On First Bootstrap Capacitor Charging

8.8.3 HI HO Propagation Delay

(CH2 (LO), CH1(HI), CH3(HO), CH4(VDD))

HO was measured with a 1:20 differential probe)

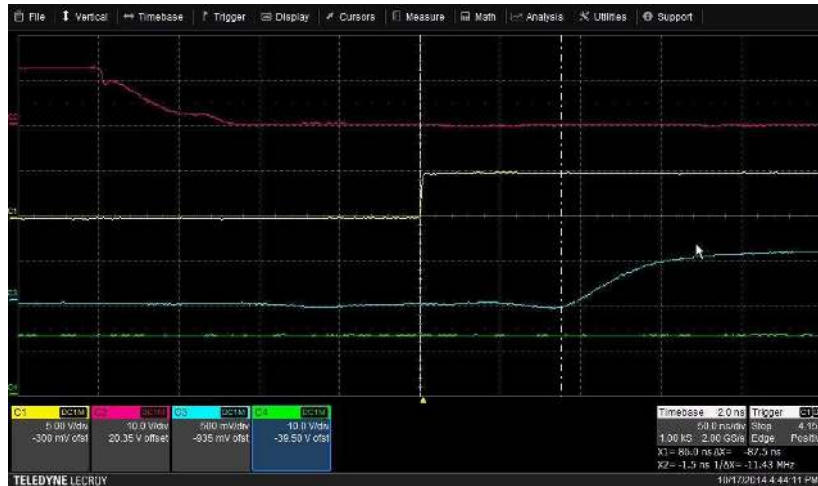

Figure 23. HI, HO Turn-On Propagation Delay

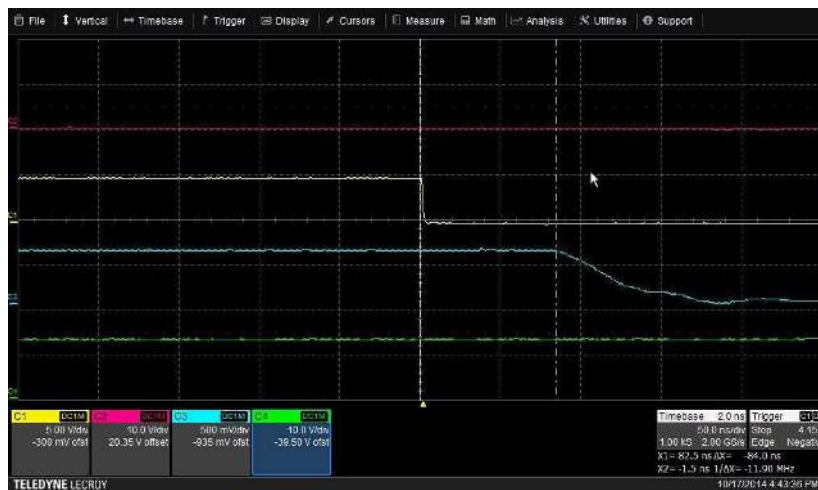

Figure 24. HI, HO Turn-Off Propagation Delay

8.8.4 HB (CH2), HI(CH1), HO(CH3), LO(CH4) During Power Up

1. HB and HO were measured with 1:20 differential probes.
2. HB charges up on first LO pulse.
3. HO will not become active on the first HI pulse.
 - Includes a built-in fixed delay, please refer to the [UCC27714](#) data sheet for details.

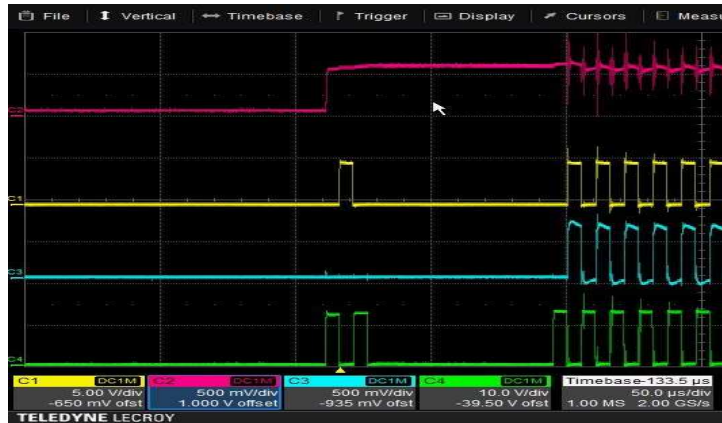

Figure 25. HB and HO Measurement During Start Up

8.8.5 Q3g(CH1), Q1g(CH3), Q4g(Ch2), Q2g(Ch4) During Soft-Start Power Up

1. VBIAS1 and VBIAS2 set at 11 V.
2. [UCC28950](#) soft start capacitor C2 pulled to ground and then released to activate soft start.
3. Q1g and Q2g measured with 1:20 differential probes.
4. Q1g and Q2g are driven with HO pins from the [UCC27714](#) U1 and U2.

There is roughly a 90us delay before the HO outputs become active.

This is a combination of the [UCC28950](#)'s burst mode function and [UCC27714](#) built-in delay check the device data sheets for delay details.



Figure 26. Q_g Measurement During Startup

[UCC28950](#) during soft start enters burst mode.

Please refer to the [UCC28950](#) data sheet for details.



Figure 27. UCC28950 Burst-Mode Function

Q3g (CH1), Q1g (CH3), Q4g (Ch2), Q2g (V_{OUT}) during soft-start startup.

Ch1 = 1:20 differential probe.



Figure 28. UCC28950 Burst-Mode Function During Soft Start

9 Assembly Drawings and Layout

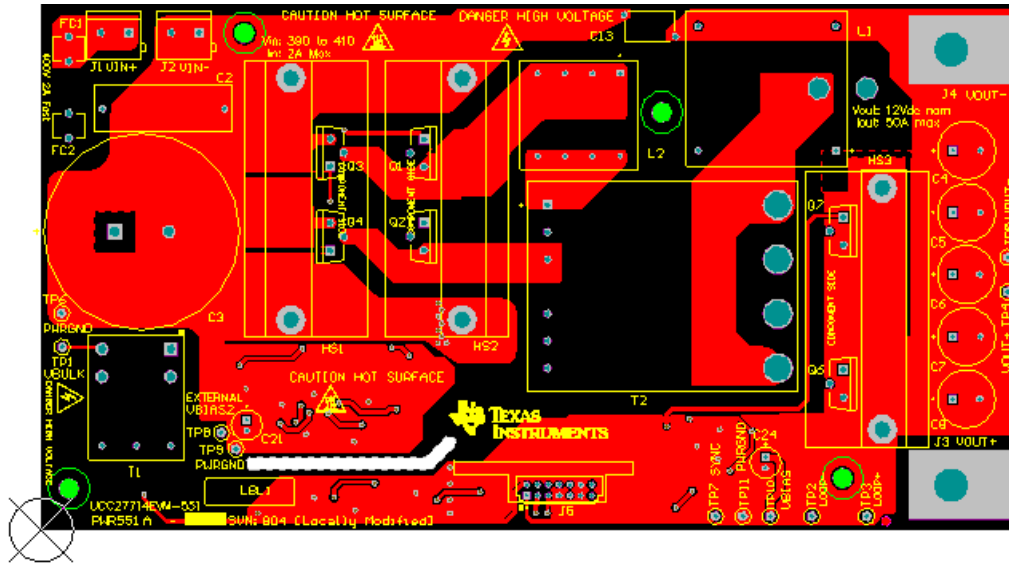

Figure 29. UCC27714EVM-551 Power Stage Top Layer Assembly Drawing (top view)

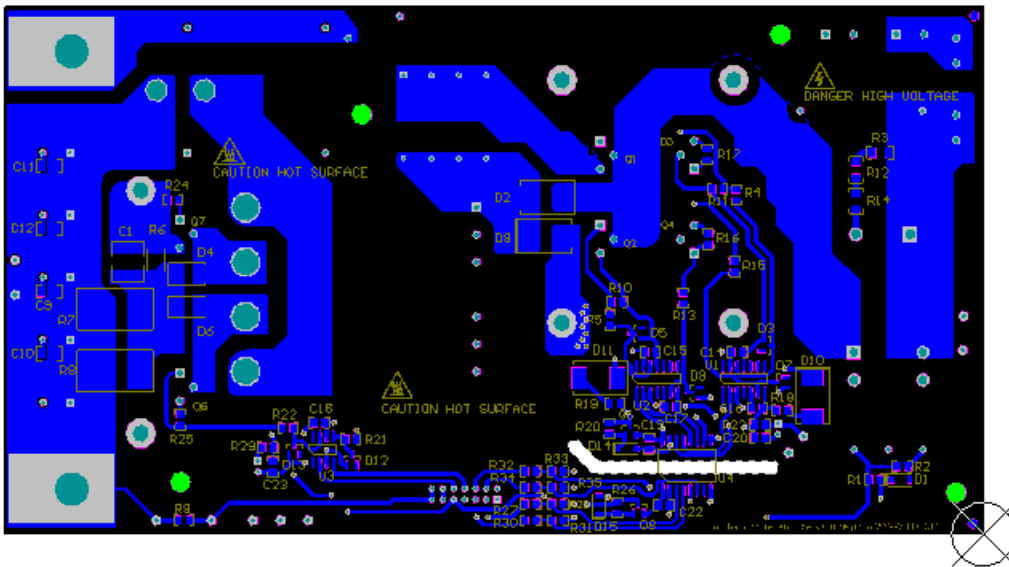

Figure 30. UCC27714EVM-551 Power Stage Bottom Layer Assembly Drawing (bottom view)

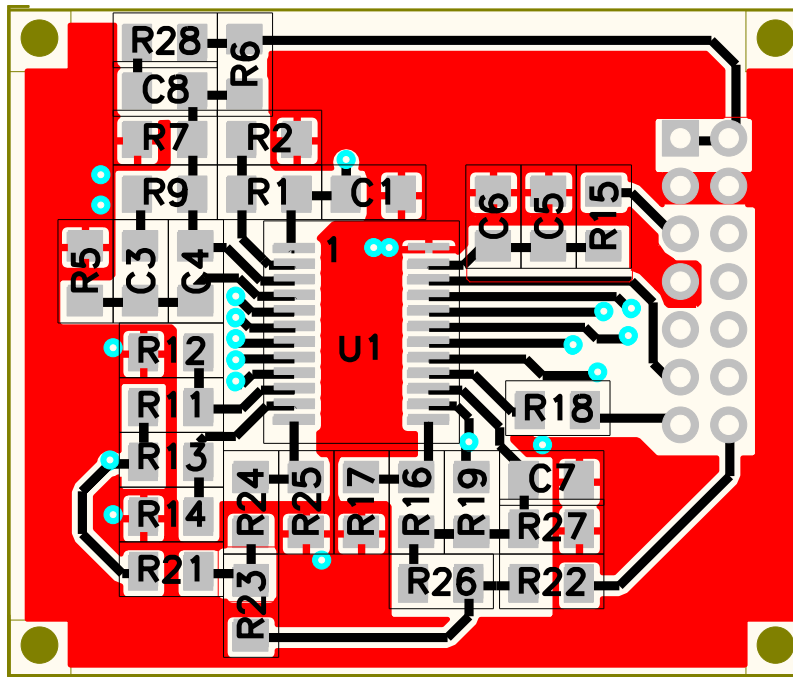

Figure 31. UCC27714EVM-551 Daughter Controller Card Top Layer Assembly Drawing (top view)

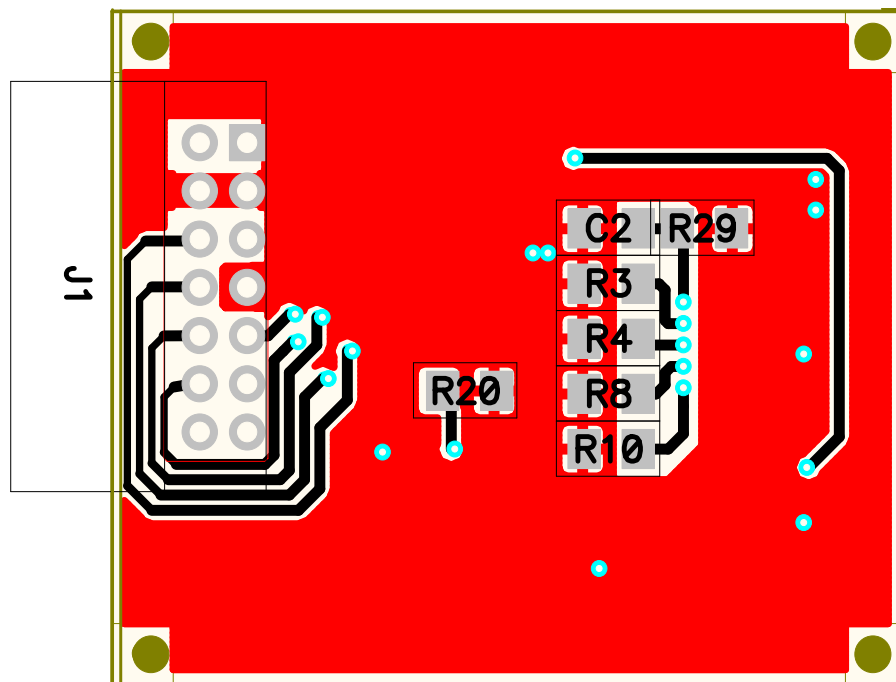

Figure 32. UCC27714EVM-551 Daughter Controller Card Bottom Layer Assembly Drawing (bottom view)

10 List of Materials

**Table 4. UCC27714EVM-551 Power Stage Components List of Materials
(list according to the schematic in Figure 1)**

COUNT	REF DES	DESCRIPTION	PART NUMBER	MFR
1	PCB	Printed circuit board	PWR551	Any
1	C1	Capacitor, ceramic, 220 nF, 100 V X7R, ±10%, 2220	C2220C224J1GACTU	Kemet
1	C2	Capacitor, film, 0.47 µF, 275 V _{AC} , ±20%	ECQ-U2A474MG	Panasonic
1	C3	Capacitor, 450 V, 330 µF, temperature -255 to 105°C, ±20%	EETHC2W331EA	Panasonic
5	C4, C5, C6, C7, C8	Capacitor, low impedance, 16 V, 1500 µF, ±20%	EKY-160ELL152MJ30S	Nippon
4	C9, C10, C11, C12	Capacitor, ceramic, 25 V, 1 µF, X7R, ±10%,1206	C3216X7R1E105K085A	TDK
1	C13	Capacitor, ceramic disk, 1000 pF, 500 V _{AC}	440LD10	Vishay-Sprague
2	C14, C15	Capacitor, ceramic, 50 V, 100 nF, X7R, ±10%,0805	C1608X7R1H104K080A	TDK
7	C16, C17, C18, C19, C20, C22, C23	Capacitor, ceramic, 50 V, 1 µF, X7R, ±10%,0805	C2012X7R1H105K125A	TDK
2	C21, C24	Capacitor, aluminum, 35 V, 22 µF, ±20%	ECA-1VM220-R	Panasonic
1	D1	Diode, signal, 200 mA, 100 V, 350 mW, SOD123	1N4148W-7-F	Diodes
4	D2, D9, D10, D11	Diode, 3000 mA, 600 V, SMC	MURS360T3G	ON Semiconductor
6	D3, D5, D7, D8, D12, D13	Diode, Schottky, 200 mA, 30 V, SOT23	BAT54	Vishay-Liteon
2	D4, D6	Diode, 3000 mA, 100 V, SMB	ES3BB-13-F	Diodes Inc
2	D14, D15	Diode, Zener, 5.6 V, 20 mA, SOD-123	MMSZ5232B-V-GS08	Vishay
2	F1	Fuse clip	0100056H	Wickmann
4	H1, H2, H3, H4	Machine screw, round, #4-40 x 1/4, nylon, Philips panhead, screw	NY PMS 440 0025 PH	B&F Fastener Supply
4	H5, H6, H7, H8	Standoff, hex, 0.5"L #4-40 nylon, standoff	1902C	Keystone
3	HS1, HS2, HS3	H _{EATSINK}	782653B02000	Aavid
2	J1, J2	Terminal block, 2 pin, 15 A, 5.1 mm	ED120/2DS	OST
2	J3, J4	Copper, single barrel, one-hole, straight tongue (fixed) lug, #14 - #4 AWG wire, 1/4 stud hole."	CX70-14-CY	Panduit
1	J5	Conn receipt 14 pos 2mm PCB tin female	DF11-14DS-2DSA(05)	HRS
1	L1	Inductor, 2.0 µH	75PR8108	Vitec Electronics Corp
1	L2	Inductor, 26 µH	60PR964	Vitec Electronics Corp.
4	Q1, Q2, Q3, Q4	MOSFET, N-channel, 650 V, 20 A, 220 mΩ, TO-220V	SPP20N60CFD	Infineon
2	Q5, Q8	Transistor, NPN, high performance, 500 mA, SOT-23	MMBT2222A	Fairchild
2	Q6, Q7	MOSFET, N-channel, 80 V, 273 A, 2.0 mΩ, TO-220 V	CSD19506KCS	TI
1	R1	Resistor, chip, 48.7 Ω, 1/10 W, 1%, 0805	ERJ-2RKF48R7X	Panasonic
1	R2	Resistor, chip, 4.87 kΩ, 1/10 W, 1%, 0805	ERJ-6ENF4871V	Panasonic
3	R3, R12, R14	Resistor, chip, 1.00 MΩ, 1/10 W, 5%, 0805	ERJ-6GEYJ105V	Panasonic
4	R4, R5, R13, R15,	Resistor, chip, 3.01 Ω, 1/10 W, 1%, 0805	CRCW08053R01FKEA	Vishay
2	R21, R22	Resistor, chip, 6.19 Ω, 1/10 W, 1%, 0805	CRCW08056R19FKEA	Vishay

**Table 4. UCC27714EVM-551 Power Stage Components List of Materials
(list according to the schematic in Figure 1) (continued)**

COUNT	REF DES	DESCRIPTION	PART NUMBER	MFR
1	R6	Resistor, chip, 100 k Ω , 1 W, 1%, 2512	CRCW2512100KFKEG	Vishay
2	R7, R8	Power metal strip, 1.00 k Ω , 2 W, \pm 5%, 4527	WSC45271K000FEA	Vishay
1	R9	Resistor, chip, 49.9 Ω , 1/10 W, 1%, 0805	ERJ-6ENF1001V	Panasonic
6	R10, R11, R16, R17, R24, R25	Resistor, chip, 10.0 k Ω , 1/10 W, 1%, 0805	ERJ-6ENF1002V	Panasonic
2	R18, R19	Resistor, chip, 2.2 Ω , 1/10 W, 1%, 0805	ERJ-6GEYJ105V	Panasonic
6	R20, R26, R27, R30, R32, R34	Resistor, chip, 7.15 k Ω , 1/10 W, 1%, 0805	ERJ-6ENF7151V	Panasonic
2	R23, R29	Resistor, chip, 5.11 Ω , 1/10 W, 1%, 0805	ERJ-6GEY0R00V	Panasonic
4	R28, R31, R33, R35	Resistor, Chip, 5.11 k Ω , 1/10 W, 1%, 0805	ERJ-6ENF5111V	Panasonic
1	T1	XFMR, current sense	PE63587	Pulse
1	T2	Transformer	75PR8107	Vitec Electronics
11	TP1, TP2, TP3, TP4, TP5, TP6, TP7, TP8, TP9, TP10, TP11	Pin, thru hole, tin plate, for 0.062 PCB's	K24A/M	Vector
2	U1, U2	High-Speed Low-side Gate Driver Device, D0014A	UCC27714D14	Texas Instruments
1	U3	High Speed Low Side Power MOSFET driver, SO8	UCC27324AD	TI
1	U4	Low-Power Quad-Channel Digital Isolator, SOIC-16	SI8640BD-B-IS	Silicon Laboratories
ADDITIONAL HARDWARE				
1	X1 at F1	2-A, fast acting fuse	BK/S501-2-R	Cooper/Bussman
6	X1 at HS1, HS2, HS3	Screw steel M3 THR 6 mm	29311	Keystone Electronics
6	X1 at HS1, HS2, HS3	Washer lock metric M 3 ZINC	MLWZ 003	B&F Fastener Supply
6	X1 at HS1,HS2, HS3, Q1, Q2 Q3, Q4, Q5, Q6	Thermal pad tube, needs to be cut to 22 mm	BER156-ND	Bergquist
6	X1 at HS1, HS2, HS3, Q1, Q2, Q3, Q4, Q5, Q6	MAX clip	MAX01G	Aavid
1	X2 at J5	UCC28950 daughter card assembly	HPA471	Any
4	At PCB	Standoff hex .500/6-32THR nylon, mount on bottom of PCB	1903C	Keystone Electronics
4	At PCB	Nut, mount to top of PCB	4824	Keystone Electronics

**Table 5. UCC27714EVM-551 Daughter Controller Card Power Stage List of Materials
(list according to the schematic in Figure 2)**

COUNT	REF DES	DESCRIPTION	PART NUMBER	MFR
2	C1, C5	Capacitor, ceramic, 25 V, 1 μ F, X7R, \pm 10%, 0805	Std	Std
1	C2	Capacitor, ceramic, 50 V, 150 nF, X7R, \pm 10%, 0805	Std	Std
1	C3	Capacitor, ceramic, 50 V, 5.6 nF, X7R, \pm 10%, 0805	Std	Std
1	C4	Capacitor, ceramic, 25 V, 560 pF, X7R, \pm 10%, 0805	Std	Std
1	C6	Capacitor, ceramic, 25 V, 0.1 μ F, X7R, \pm 10%, 0805	Std	Std
1	C7	Capacitor, ceramic, 25 V, 330 pF, X7R, \pm 10%, 0805	Std	Std
0	C8	Capacitor, ceramic, 25 V, no pop, X7R, \pm 10%, 0805	Std	Std
1	J1	Conn header 14 pos 2 mm R/A gold, male, right angle	DF11-14DP-2DS(52)	HRS
1		EVM daughter board PCB	HPA471	Any
3	R1, R2, R7	Resistor, chip, 2.37 k Ω , 1/10 W, 1%, 0805	Std	Std
1	R10	Resistor, chip, 13.3 k Ω , 1/10 W, 1%, 0805	Std	Std
1	R11	Resistor, chip, 61.9 k Ω , 1/10 W, 1%, 0805	Std	Std
1	R14	Resistor, chip, 127 k Ω , 1/10 W, 1%, 0805	Std	Std
1	R15	Resistor, chip, 22.6 Ω , 1/10 W, 1%, 0805	Std	Std
4	R17, R20, R21, R26	Resistor, chip, 0 Ω , 1/10 W, 1%, 0805	Std	Std
3	R18, R22, R25	Resistor, chip, 1.00 k Ω , 1/10 W, 1%, 0805	Std	Std
1	R24	Resistor, chip, 16.9 k Ω , 1/10 W, 1%, 0805	Std	Std
1	R29	Resistor, chip, 825 V, 1/10 W, 1%, 0805	Std	Std
2	R3, R4	Resistor, chip, 12.1 k Ω , 1/10 W, 1%, 0805	Std	Std
0	R5, R12, R13, R16, R19, R23, R27, R28	Resistor, chip, no pop, 1/10 W, 1%, 0805	Std	Std
1	R6	Resistor, chip, 9.09 k Ω , 1/10 W, 1%, 0805	Std	Std
1	R8	Resistor, chip, 56.2 k Ω , 1/10 W, 1%, 0805	Std	Std
1	R9	Resistor, chip, 27.4 k Ω , 1/10 W, 1%, 0805	Std	Std
1	U1	Advanced Phase-Shifted PWM Controller, TSSOP-24	UCC28950PW	TI

Revision History

Changes from Original (July 2015) to A Revision	Page
• Added High Voltage warning notices.	2

NOTE: Page numbers for previous revisions may differ from page numbers in the current version.

STANDARD TERMS AND CONDITIONS FOR EVALUATION MODULES

1. *Delivery:* TI delivers TI evaluation boards, kits, or modules, including any accompanying demonstration software, components, or documentation (collectively, an "EVM" or "EVMs") to the User ("User") in accordance with the terms and conditions set forth herein. Acceptance of the EVM is expressly subject to the following terms and conditions.
 - 1.1 EVMs are intended solely for product or software developers for use in a research and development setting to facilitate feasibility evaluation, experimentation, or scientific analysis of TI semiconductors products. EVMs have no direct function and are not finished products. EVMs shall not be directly or indirectly assembled as a part or subassembly in any finished product. For clarification, any software or software tools provided with the EVM ("Software") shall not be subject to the terms and conditions set forth herein but rather shall be subject to the applicable terms and conditions that accompany such Software
 - 1.2 EVMs are not intended for consumer or household use. EVMs may not be sold, sublicensed, leased, rented, loaned, assigned, or otherwise distributed for commercial purposes by Users, in whole or in part, or used in any finished product or production system.
2. *Limited Warranty and Related Remedies/Disclaimers:*
 - 2.1 These terms and conditions do not apply to Software. The warranty, if any, for Software is covered in the applicable Software License Agreement.
 - 2.2 TI warrants that the TI EVM will conform to TI's published specifications for ninety (90) days after the date TI delivers such EVM to User. Notwithstanding the foregoing, TI shall not be liable for any defects that are caused by neglect, misuse or mistreatment by an entity other than TI, including improper installation or testing, or for any EVMs that have been altered or modified in any way by an entity other than TI. Moreover, TI shall not be liable for any defects that result from User's design, specifications or instructions for such EVMs. Testing and other quality control techniques are used to the extent TI deems necessary or as mandated by government requirements. TI does not test all parameters of each EVM.
 - 2.3 If any EVM fails to conform to the warranty set forth above, TI's sole liability shall be at its option to repair or replace such EVM, or credit User's account for such EVM. TI's liability under this warranty shall be limited to EVMs that are returned during the warranty period to the address designated by TI and that are determined by TI not to conform to such warranty. If TI elects to repair or replace such EVM, TI shall have a reasonable time to repair such EVM or provide replacements. Repaired EVMs shall be warranted for the remainder of the original warranty period. Replaced EVMs shall be warranted for a new full ninety (90) day warranty period.
3. *Regulatory Notices:*
 - 3.1 *United States*
 - 3.1.1 *Notice applicable to EVMs not FCC-Approved:*

This kit is designed to allow product developers to evaluate electronic components, circuitry, or software associated with the kit to determine whether to incorporate such items in a finished product and software developers to write software applications for use with the end product. This kit is not a finished product and when assembled may not be resold or otherwise marketed unless all required FCC equipment authorizations are first obtained. Operation is subject to the condition that this product not cause harmful interference to licensed radio stations and that this product accept harmful interference. Unless the assembled kit is designed to operate under part 15, part 18 or part 95 of this chapter, the operator of the kit must operate under the authority of an FCC license holder or must secure an experimental authorization under part 5 of this chapter.
 - 3.1.2 *For EVMs annotated as FCC – FEDERAL COMMUNICATIONS COMMISSION Part 15 Compliant:*

CAUTION

This device complies with part 15 of the FCC Rules. Operation is subject to the following two conditions: (1) This device may not cause harmful interference, and (2) this device must accept any interference received, including interference that may cause undesired operation.

Changes or modifications not expressly approved by the party responsible for compliance could void the user's authority to operate the equipment.

FCC Interference Statement for Class A EVM devices

NOTE: This equipment has been tested and found to comply with the limits for a Class A digital device, pursuant to part 15 of the FCC Rules. These limits are designed to provide reasonable protection against harmful interference when the equipment is operated in a commercial environment. This equipment generates, uses, and can radiate radio frequency energy and, if not installed and used in accordance with the instruction manual, may cause harmful interference to radio communications. Operation of this equipment in a residential area is likely to cause harmful interference in which case the user will be required to correct the interference at his own expense.

FCC Interference Statement for Class B EVM devices

NOTE: This equipment has been tested and found to comply with the limits for a Class B digital device, pursuant to part 15 of the FCC Rules. These limits are designed to provide reasonable protection against harmful interference in a residential installation. This equipment generates, uses and can radiate radio frequency energy and, if not installed and used in accordance with the instructions, may cause harmful interference to radio communications. However, there is no guarantee that interference will not occur in a particular installation. If this equipment does cause harmful interference to radio or television reception, which can be determined by turning the equipment off and on, the user is encouraged to try to correct the interference by one or more of the following measures:

- Reorient or relocate the receiving antenna.
- Increase the separation between the equipment and receiver.
- Connect the equipment into an outlet on a circuit different from that to which the receiver is connected.
- Consult the dealer or an experienced radio/TV technician for help.

3.2 Canada

3.2.1 For EVMs issued with an Industry Canada Certificate of Conformance to RSS-210

Concerning EVMs Including Radio Transmitters:

This device complies with Industry Canada license-exempt RSS standard(s). Operation is subject to the following two conditions: (1) this device may not cause interference, and (2) this device must accept any interference, including interference that may cause undesired operation of the device.

Concernant les EVMs avec appareils radio:

Le présent appareil est conforme aux CNR d'Industrie Canada applicables aux appareils radio exempts de licence. L'exploitation est autorisée aux deux conditions suivantes: (1) l'appareil ne doit pas produire de brouillage, et (2) l'utilisateur de l'appareil doit accepter tout brouillage radioélectrique subi, même si le brouillage est susceptible d'en compromettre le fonctionnement.

Concerning EVMs Including Detachable Antennas:

Under Industry Canada regulations, this radio transmitter may only operate using an antenna of a type and maximum (or lesser) gain approved for the transmitter by Industry Canada. To reduce potential radio interference to other users, the antenna type and its gain should be so chosen that the equivalent isotropically radiated power (e.i.r.p.) is not more than that necessary for successful communication. This radio transmitter has been approved by Industry Canada to operate with the antenna types listed in the user guide with the maximum permissible gain and required antenna impedance for each antenna type indicated. Antenna types not included in this list, having a gain greater than the maximum gain indicated for that type, are strictly prohibited for use with this device.

Concernant les EVMs avec antennes détachables

Conformément à la réglementation d'Industrie Canada, le présent émetteur radio peut fonctionner avec une antenne d'un type et d'un gain maximal (ou inférieur) approuvé pour l'émetteur par Industrie Canada. Dans le but de réduire les risques de brouillage radioélectrique à l'intention des autres utilisateurs, il faut choisir le type d'antenne et son gain de sorte que la puissance isotrope rayonnée équivalente (p.i.r.e.) ne dépasse pas l'intensité nécessaire à l'établissement d'une communication satisfaisante. Le présent émetteur radio a été approuvé par Industrie Canada pour fonctionner avec les types d'antenne énumérés dans le manuel d'usage et ayant un gain admissible maximal et l'impédance requise pour chaque type d'antenne. Les types d'antenne non inclus dans cette liste, ou dont le gain est supérieur au gain maximal indiqué, sont strictement interdits pour l'exploitation de l'émetteur.

3.3 Japan

3.3.1 *Notice for EVMs delivered in Japan:* Please see http://www.tij.co.jp/lstds/ti_ja/general/eStore/notice_01.page 日本国内に輸入される評価用キット、ボードについては、次のところをご覧ください。
http://www.tij.co.jp/lstds/ti_ja/general/eStore/notice_01.page

3.3.2 *Notice for Users of EVMs Considered "Radio Frequency Products" in Japan:* EVMs entering Japan may not be certified by TI as conforming to Technical Regulations of Radio Law of Japan.

If User uses EVMs in Japan, not certified to Technical Regulations of Radio Law of Japan, User is required by Radio Law of Japan to follow the instructions below with respect to EVMs:

1. Use EVMs in a shielded room or any other test facility as defined in the notification #173 issued by Ministry of Internal Affairs and Communications on March 28, 2006, based on Sub-section 1.1 of Article 6 of the Ministry's Rule for Enforcement of Radio Law of Japan,
2. Use EVMs only after User obtains the license of Test Radio Station as provided in Radio Law of Japan with respect to EVMs, or
3. Use of EVMs only after User obtains the Technical Regulations Conformity Certification as provided in Radio Law of Japan with respect to EVMs. Also, do not transfer EVMs, unless User gives the same notice above to the transferee. Please note that if User does not follow the instructions above, User will be subject to penalties of Radio Law of Japan.

【無線電波を送信する製品の開発キットをお使いになる際の注意事項】 開発キットの中には技術基準適合証明を受けていないものがあります。技術適合証明を受けていないもののご使用に際しては、電波法遵守のため、以下のいずれかの措置を取っていただく必要がありますのでご注意ください。

1. 電波法施行規則第6条第1項第1号に基づく平成18年3月28日総務省告示第173号で定められた電波暗室等の試験設備でご使用いただく。
2. 実験局の免許を取得後ご使用いただく。
3. 技術基準適合証明を取得後ご使用いただく。

なお、本製品は、上記の「ご使用にあたっての注意」を譲渡先、移転先に通知しない限り、譲渡、移転できないものとします。

上記を遵守頂けない場合は、電波法の罰則が適用される可能性があることをご留意ください。日本テキサス・インスツルメンツ株式会社
東京都新宿区西新宿 6 丁目 2 4 番 1 号
西新宿三井ビル

3.3.3 *Notice for EVMs for Power Line Communication:* Please see http://www.tij.co.jp/llds/ti_ja/general/eStore/notice_02.page
電力線搬送波通信についての開発キットをお使いになる際の注意事項については、次のところをご覧ください。http://www.tij.co.jp/llds/ti_ja/general/eStore/notice_02.page

4 *EVM Use Restrictions and Warnings:*

4.1 EVMS ARE NOT FOR USE IN FUNCTIONAL SAFETY AND/OR SAFETY CRITICAL EVALUATIONS, INCLUDING BUT NOT LIMITED TO EVALUATIONS OF LIFE SUPPORT APPLICATIONS.

4.2 User must read and apply the user guide and other available documentation provided by TI regarding the EVM prior to handling or using the EVM, including without limitation any warning or restriction notices. The notices contain important safety information related to, for example, temperatures and voltages.

4.3 *Safety-Related Warnings and Restrictions:*

4.3.1 User shall operate the EVM within TI's recommended specifications and environmental considerations stated in the user guide, other available documentation provided by TI, and any other applicable requirements and employ reasonable and customary safeguards. Exceeding the specified performance ratings and specifications (including but not limited to input and output voltage, current, power, and environmental ranges) for the EVM may cause personal injury or death, or property damage. If there are questions concerning performance ratings and specifications, User should contact a TI field representative prior to connecting interface electronics including input power and intended loads. Any loads applied outside of the specified output range may also result in unintended and/or inaccurate operation and/or possible permanent damage to the EVM and/or interface electronics. Please consult the EVM user guide prior to connecting any load to the EVM output. If there is uncertainty as to the load specification, please contact a TI field representative. During normal operation, even with the inputs and outputs kept within the specified allowable ranges, some circuit components may have elevated case temperatures. These components include but are not limited to linear regulators, switching transistors, pass transistors, current sense resistors, and heat sinks, which can be identified using the information in the associated documentation. When working with the EVM, please be aware that the EVM may become very warm.

4.3.2 EVMs are intended solely for use by technically qualified, professional electronics experts who are familiar with the dangers and application risks associated with handling electrical mechanical components, systems, and subsystems. User assumes all responsibility and liability for proper and safe handling and use of the EVM by User or its employees, affiliates, contractors or designees. User assumes all responsibility and liability to ensure that any interfaces (electronic and/or mechanical) between the EVM and any human body are designed with suitable isolation and means to safely limit accessible leakage currents to minimize the risk of electrical shock hazard. User assumes all responsibility and liability for any improper or unsafe handling or use of the EVM by User or its employees, affiliates, contractors or designees.

4.4 User assumes all responsibility and liability to determine whether the EVM is subject to any applicable international, federal, state, or local laws and regulations related to User's handling and use of the EVM and, if applicable, User assumes all responsibility and liability for compliance in all respects with such laws and regulations. User assumes all responsibility and liability for proper disposal and recycling of the EVM consistent with all applicable international, federal, state, and local requirements.

5. *Accuracy of Information:* To the extent TI provides information on the availability and function of EVMs, TI attempts to be as accurate as possible. However, TI does not warrant the accuracy of EVM descriptions, EVM availability or other information on its websites as accurate, complete, reliable, current, or error-free.

6. *Disclaimers:*
- 6.1 EXCEPT AS SET FORTH ABOVE, EVMS AND ANY WRITTEN DESIGN MATERIALS PROVIDED WITH THE EVM (AND THE DESIGN OF THE EVM ITSELF) ARE PROVIDED "AS IS" AND "WITH ALL FAULTS." TI DISCLAIMS ALL OTHER WARRANTIES, EXPRESS OR IMPLIED, REGARDING SUCH ITEMS, INCLUDING BUT NOT LIMITED TO ANY IMPLIED WARRANTIES OF MERCHANTABILITY OR FITNESS FOR A PARTICULAR PURPOSE OR NON-INFRINGEMENT OF ANY THIRD PARTY PATENTS, COPYRIGHTS, TRADE SECRETS OR OTHER INTELLECTUAL PROPERTY RIGHTS.
- 6.2 EXCEPT FOR THE LIMITED RIGHT TO USE THE EVM SET FORTH HEREIN, NOTHING IN THESE TERMS AND CONDITIONS SHALL BE CONSTRUED AS GRANTING OR CONFERRING ANY RIGHTS BY LICENSE, PATENT, OR ANY OTHER INDUSTRIAL OR INTELLECTUAL PROPERTY RIGHT OF TI, ITS SUPPLIERS/LICENSORS OR ANY OTHER THIRD PARTY, TO USE THE EVM IN ANY FINISHED END-USER OR READY-TO-USE FINAL PRODUCT, OR FOR ANY INVENTION, DISCOVERY OR IMPROVEMENT MADE, CONCEIVED OR ACQUIRED PRIOR TO OR AFTER DELIVERY OF THE EVM.
7. *USER'S INDEMNITY OBLIGATIONS AND REPRESENTATIONS.* USER WILL DEFEND, INDEMNIFY AND HOLD TI, ITS LICENSORS AND THEIR REPRESENTATIVES HARMLESS FROM AND AGAINST ANY AND ALL CLAIMS, DAMAGES, LOSSES, EXPENSES, COSTS AND LIABILITIES (COLLECTIVELY, "CLAIMS") ARISING OUT OF OR IN CONNECTION WITH ANY HANDLING OR USE OF THE EVM THAT IS NOT IN ACCORDANCE WITH THESE TERMS AND CONDITIONS. THIS OBLIGATION SHALL APPLY WHETHER CLAIMS ARISE UNDER STATUTE, REGULATION, OR THE LAW OF TORT, CONTRACT OR ANY OTHER LEGAL THEORY, AND EVEN IF THE EVM FAILS TO PERFORM AS DESCRIBED OR EXPECTED.
8. *Limitations on Damages and Liability:*
- 8.1 *General Limitations.* IN NO EVENT SHALL TI BE LIABLE FOR ANY SPECIAL, COLLATERAL, INDIRECT, PUNITIVE, INCIDENTAL, CONSEQUENTIAL, OR EXEMPLARY DAMAGES IN CONNECTION WITH OR ARISING OUT OF THESE TERMS AND CONDITIONS OR THE USE OF THE EVMS PROVIDED HEREUNDER, REGARDLESS OF WHETHER TI HAS BEEN ADVISED OF THE POSSIBILITY OF SUCH DAMAGES. EXCLUDED DAMAGES INCLUDE, BUT ARE NOT LIMITED TO, COST OF REMOVAL OR REINSTALLATION, ANCILLARY COSTS TO THE PROCUREMENT OF SUBSTITUTE GOODS OR SERVICES, RETESTING, OUTSIDE COMPUTER TIME, LABOR COSTS, LOSS OF GOODWILL, LOSS OF PROFITS, LOSS OF SAVINGS, LOSS OF USE, LOSS OF DATA, OR BUSINESS INTERRUPTION. NO CLAIM, SUIT OR ACTION SHALL BE BROUGHT AGAINST TI MORE THAN ONE YEAR AFTER THE RELATED CAUSE OF ACTION HAS OCCURRED.
- 8.2 *Specific Limitations.* IN NO EVENT SHALL TI'S AGGREGATE LIABILITY FROM ANY WARRANTY OR OTHER OBLIGATION ARISING OUT OF OR IN CONNECTION WITH THESE TERMS AND CONDITIONS, OR ANY USE OF ANY TI EVM PROVIDED HEREUNDER, EXCEED THE TOTAL AMOUNT PAID TO TI FOR THE PARTICULAR UNITS SOLD UNDER THESE TERMS AND CONDITIONS WITH RESPECT TO WHICH LOSSES OR DAMAGES ARE CLAIMED. THE EXISTENCE OF MORE THAN ONE CLAIM AGAINST THE PARTICULAR UNITS SOLD TO USER UNDER THESE TERMS AND CONDITIONS SHALL NOT ENLARGE OR EXTEND THIS LIMIT.
9. *Return Policy.* Except as otherwise provided, TI does not offer any refunds, returns, or exchanges. Furthermore, no return of EVM(s) will be accepted if the package has been opened and no return of the EVM(s) will be accepted if they are damaged or otherwise not in a resalable condition. If User feels it has been incorrectly charged for the EVM(s) it ordered or that delivery violates the applicable order, User should contact TI. All refunds will be made in full within thirty (30) working days from the return of the components(s), excluding any postage or packaging costs.
10. *Governing Law:* These terms and conditions shall be governed by and interpreted in accordance with the laws of the State of Texas, without reference to conflict-of-laws principles. User agrees that non-exclusive jurisdiction for any dispute arising out of or relating to these terms and conditions lies within courts located in the State of Texas and consents to venue in Dallas County, Texas. Notwithstanding the foregoing, any judgment may be enforced in any United States or foreign court, and TI may seek injunctive relief in any United States or foreign court.

Mailing Address: Texas Instruments, Post Office Box 655303, Dallas, Texas 75265
Copyright © 2015, Texas Instruments Incorporated

IMPORTANT NOTICE

Texas Instruments Incorporated and its subsidiaries (TI) reserve the right to make corrections, enhancements, improvements and other changes to its semiconductor products and services per JESD46, latest issue, and to discontinue any product or service per JESD48, latest issue. Buyers should obtain the latest relevant information before placing orders and should verify that such information is current and complete. All semiconductor products (also referred to herein as "components") are sold subject to TI's terms and conditions of sale supplied at the time of order acknowledgment.

TI warrants performance of its components to the specifications applicable at the time of sale, in accordance with the warranty in TI's terms and conditions of sale of semiconductor products. Testing and other quality control techniques are used to the extent TI deems necessary to support this warranty. Except where mandated by applicable law, testing of all parameters of each component is not necessarily performed.

TI assumes no liability for applications assistance or the design of Buyers' products. Buyers are responsible for their products and applications using TI components. To minimize the risks associated with Buyers' products and applications, Buyers should provide adequate design and operating safeguards.

TI does not warrant or represent that any license, either express or implied, is granted under any patent right, copyright, mask work right, or other intellectual property right relating to any combination, machine, or process in which TI components or services are used. Information published by TI regarding third-party products or services does not constitute a license to use such products or services or a warranty or endorsement thereof. Use of such information may require a license from a third party under the patents or other intellectual property of the third party, or a license from TI under the patents or other intellectual property of TI.

Reproduction of significant portions of TI information in TI data books or data sheets is permissible only if reproduction is without alteration and is accompanied by all associated warranties, conditions, limitations, and notices. TI is not responsible or liable for such altered documentation. Information of third parties may be subject to additional restrictions.

Resale of TI components or services with statements different from or beyond the parameters stated by TI for that component or service voids all express and any implied warranties for the associated TI component or service and is an unfair and deceptive business practice. TI is not responsible or liable for any such statements.

Buyer acknowledges and agrees that it is solely responsible for compliance with all legal, regulatory and safety-related requirements concerning its products, and any use of TI components in its applications, notwithstanding any applications-related information or support that may be provided by TI. Buyer represents and agrees that it has all the necessary expertise to create and implement safeguards which anticipate dangerous consequences of failures, monitor failures and their consequences, lessen the likelihood of failures that might cause harm and take appropriate remedial actions. Buyer will fully indemnify TI and its representatives against any damages arising out of the use of any TI components in safety-critical applications.

In some cases, TI components may be promoted specifically to facilitate safety-related applications. With such components, TI's goal is to help enable customers to design and create their own end-product solutions that meet applicable functional safety standards and requirements. Nonetheless, such components are subject to these terms.

No TI components are authorized for use in FDA Class III (or similar life-critical medical equipment) unless authorized officers of the parties have executed a special agreement specifically governing such use.

Only those TI components which TI has specifically designated as military grade or "enhanced plastic" are designed and intended for use in military/aerospace applications or environments. Buyer acknowledges and agrees that any military or aerospace use of TI components which have **not** been so designated is solely at the Buyer's risk, and that Buyer is solely responsible for compliance with all legal and regulatory requirements in connection with such use.

TI has specifically designated certain components as meeting ISO/TS16949 requirements, mainly for automotive use. In any case of use of non-designated products, TI will not be responsible for any failure to meet ISO/TS16949.

Products

Audio	www.ti.com/audio
Amplifiers	amplifier.ti.com
Data Converters	dataconverter.ti.com
DLP® Products	www.dlp.com
DSP	dsp.ti.com
Clocks and Timers	www.ti.com/clocks
Interface	interface.ti.com
Logic	logic.ti.com
Power Mgmt	power.ti.com
Microcontrollers	microcontroller.ti.com
RFID	www.ti-rfid.com
OMAP Applications Processors	www.ti.com/omap
Wireless Connectivity	www.ti.com/wirelessconnectivity

Applications

Automotive and Transportation	www.ti.com/automotive
Communications and Telecom	www.ti.com/communications
Computers and Peripherals	www.ti.com/computers
Consumer Electronics	www.ti.com/consumer-apps
Energy and Lighting	www.ti.com/energy
Industrial	www.ti.com/industrial
Medical	www.ti.com/medical
Security	www.ti.com/security
Space, Avionics and Defense	www.ti.com/space-avionics-defense
Video and Imaging	www.ti.com/video

TI E2E Community

e2e.ti.com