

THIS INFORMATION IS CONFIDENTIAL AND IS DISCLOSED TO YOU ON CONDITION THAT NO FURTHER DISCLOSURE IS MADE BY YOU TO OTHER THAN CHOGORI PERSONNEL WITHOUT AUTHORIZATION FROM CHOGORI CORP.

REV.	ECN NO.	DESCRIPTION	SIGN	DATE
C1	N/A	INITIAL DRAWING	Liu	2019/08/08

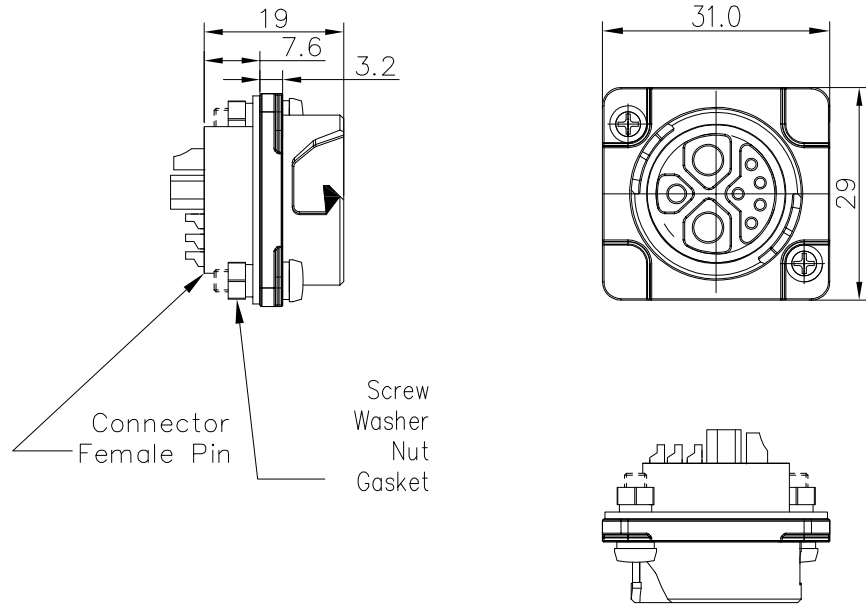

- Specification:
- 1.Operation Temperature:  $-45^{\circ}\text{C}\sim 105^{\circ}\text{C}$ .
  - 2.Insulation Resistance:  $100\text{M}\Omega$  at DC500V.
  - 3.Contact Resistance:  $<10\text{m}\Omega$ .
  - 4.Withstand Voltage: 1500V AC, 1min
  - 5.Operating Current: 50A+15A+5A
  - 6.Operating Voltage: AC 250V
  - 7.Waterproof Rate: IP67 (Mated)
  - 8.Housing: Nylon, Black
  - 9.Female Pin: Copper Alloy, Gold Plated
  - 10.Gasket: Silicon Black
  - 11.Screw: Stainless Steel
  - 12.Washe: Stainless Steel
  - 13.Nut: Stainless Steel
  - 14.RoHS Compliant.
  - 15.Mating Cap P/N: 806-00058-00

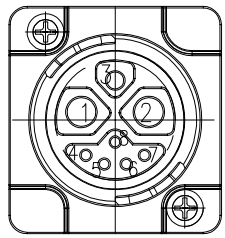

2+1+5 Pos

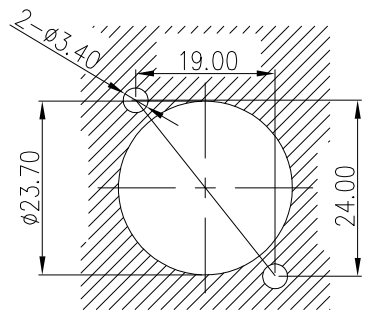

RECOMMENDED PANEL CUT-OUT  
Panel Thickness MAX 5mm

Pin Assignments  
Front View

UNIT:mm	DESCRIPTION Large Series 2+1+5 Pos Push Lock Rear Mount With Female Pin	
TOLERANCE .X ±0.25 .XX ±0.15 .XXX ±0.05 ANGLES ±1°	SCALE: N/A	SHEET 1 OF 1
REV. C1	SIZE A4	* :Inspection Item

**CHOGORI**

PART NO 24305636-01	DRAWN BY Liu	DATE 2019/08/08
DWG NO	CHECKED BY Mo	DATE 2019/08/08
CUSTOMER	APPROVED BY	DATE