

# TL592B DIFFERENTIAL VIDEO AMPLIFIER

SLFS001A - JUNE 1985 - REVISED APRIL 1988

- Adjustable Gain to 400 Typ
- No Frequency Compensation Required
- Low Noise . . . 3  $\mu$ V Typ  $V_n$

## description

This device is a monolithic two-stage video amplifier with differential inputs and differential outputs. It features internal series-shunt feedback that provides wide bandwidth, low phase distortion, and excellent gain stability. Emitter-follower outputs enable the device to drive capacitive loads. All stages are current-source biased to obtain high common-mode and supply-voltage rejection ratios.

The differential gain is typically 400 when the gain adjust pins are connected together, or amplification may be adjusted for near 0 to 400 by the use of a single external resistor connected between the gain adjustment pins A and B. No external frequency-compensating components are required for any gain option.

The device is particularly useful in magnetic-tape or disk-file systems using phase or NRZ encoding and in high-speed thin-film or plated-wire memories. Other applications include general-purpose video and pulse amplifiers.

The device achieves low equivalent noise voltage through special processing and a new circuit layout incorporating input transistors with low base resistance.

The TL592B is characterized for operation from 0°C to 70°C.

**D8† OR P PACKAGE  
(TOP VIEW)**

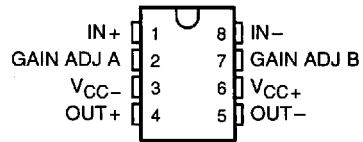

**D14† OR N PACKAGE  
(TOP VIEW)**

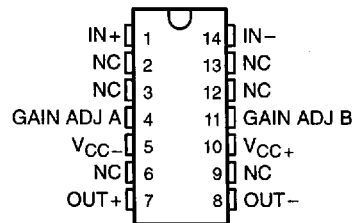

† D8 and D14 are the codes to differentiate the 8-pin and 14-pin versions, respectively.

## symbol

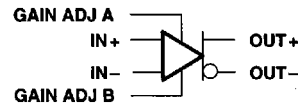

■ 8961724 0108327 829 ■

PRODUCTION DATA Information is current as of publication date. Products conform to specifications per the terms of Texas Instruments standard warranty. Production processing does not necessarily include testing of all parameters.

**TEXAS  
INSTRUMENTS**

POST OFFICE BOX 655303 • DALLAS, TEXAS 75265

Copyright © 1988, Texas Instruments Incorporated

# TL592B DIFFERENTIAL VIDEO AMPLIFIER

SLFS001A - JUNE 1985 - REVISED APRIL 1988

## schematic

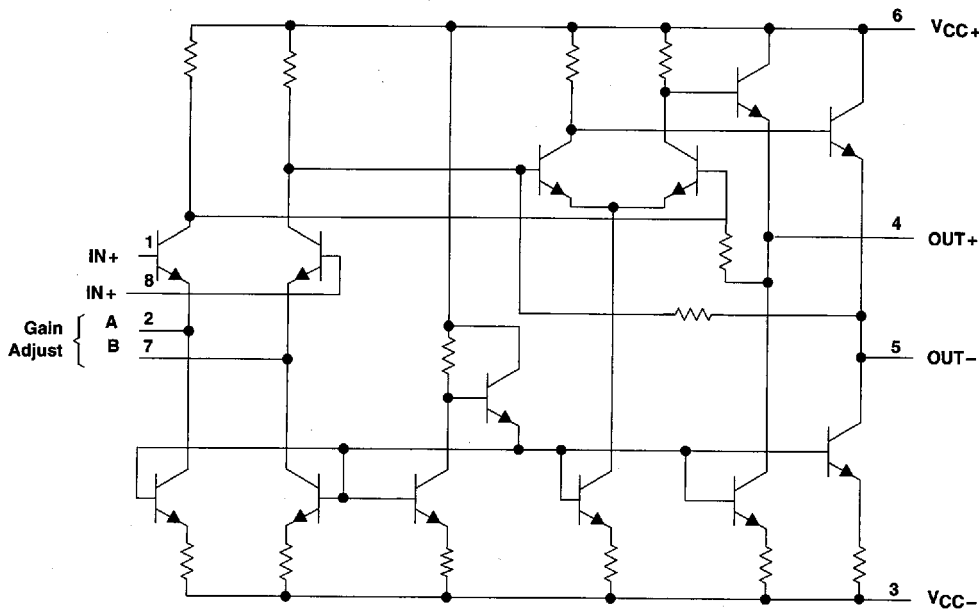

Pin numbers are for D8 and P packages.

### absolute maximum ratings over operating free-air temperature (unless otherwise noted)

Supply voltage, $V_{CC+}$ (see Note 1)	8 V
Supply voltage, $V_{CC-}$	-8 V
Differential input voltage	$\pm 5$ V
Voltage range, any input	$V_{CC+}$ to $V_{CC-}$
Output current	10 mA
Continuous total power dissipation	See Dissipation Rating Table
Operating free-air temperature range	0°C to 70°C
Storage temperature range	-65°C to 150°C
Lead temperature 1,6 mm (1/16 inch) from case for 10 seconds	260°C

NOTES: 1. All voltage values except differential input voltages are with respect to the midpoint between  $V_{CC+}$  and  $V_{CC-}$ .

DISSIPATION RATING TABLE

PACKAGE	$T_A \leq 25^\circ\text{C}$ POWER RATING	DERATING FACTOR	DERATE ABOVE $T_A$	$T_A = 70^\circ\text{C}$ POWER RATING
D8	530 mW	5.8 mW/°C	59°C	464 mW
D14	530 mW	N/A	N/A	530 mW
N	530 mW	N/A	N/A	530 mW
P	530 mW	N/A	N/A	530 mW

8961724 0108328 765

 **TEXAS  
INSTRUMENTS**

POST OFFICE BOX 655303 • DALLAS, TEXAS 75265

# TL592B DIFFERENTIAL VIDEO AMPLIFIER

SLFS001A – JUNE 1985 – REVISED APRIL 1988

## recommended operating conditions

	MIN	NOM	MAX	UNIT
Supply voltage, $V_{CC+}$	3	6	8	V
Supply voltage, $V_{CC-}$	-3	-6	-8	V
Operating free-air temperature, $T_A$	0		70	°C

## electrical characteristics at specified free-air temperature, $V_{CC\pm} = \pm 6$ V, $R_L = 2$ k $\Omega$ (unless otherwise noted)

PARAMETER	TEST FIGURE	TEST CONDITIONS†	$T_A$	MIN	TYP	MAX	UNIT
$A_{VD}$ Large-signal differential voltage amplification	1	$V_{OPP} = 3$ V, $R_L = 2$ k $\Omega$ , $R_{AB} = 0$	25°C	300	400	500	V/V
			0°C to 70°C	250		600	
$A_{VD2}$ Large-signal differential voltage amplification	1	$V_{OPP} = 3$ V, $R_L = 2$ k $\Omega$ , $R_{AB} = 1$ k $\Omega$	25°C		13		V/V
BW Bandwidth (-3 dB)	2	$V_{OPP} = 1$ V, $R_{AB} = 0$	25°C		50		MHz
$I_{IO}$ Input offset current			25°C		0.4	5	$\mu$ A
			0°C to 70°C			6	
$I_{IB}$ Input bias current			25°C		9	30	$\mu$ A
			0°C to 70°C			40	
$V_{ICR}$ Common-mode input voltage range	3		25°C	$\pm 1$			V
			0°C to 70°C	$\pm 1$			
$V_{OC}$ Common-mode output voltage	1	$R_L = \infty$	25°C	2.4	2.9	3.4	V
$V_{OO}$ Output offset voltage	1	$V_{ID} = 0$ , $R_L = \infty$ , $R_{AB} = \infty$	25°C		0.35	0.75	V
			0°C to 70°C			1.5	
$V_{OPP}$ Peak-to-peak output voltage swing	1	$R_L = 2$ k $\Omega$ , $R_{AB} = 0$	25°C	3	4		V
			0°C to 70°C	2.8			
$r_i$ Input resistance		$V_{OD} = 1$ V, $R_{AB} = 0$	25°C		4		k $\Omega$
			0°C to 70°C		3.6		
$r_o$ Output resistance			0°C to 70°C			30	$\Omega$
$C_i$ Input capacitance			25°C		5		pF
CMRR Common-mode rejection ratio	3	$V_{IC} = \pm 1$ V, $R_{AB} = 0$	25°C	f = 100 kHz	60	86	dB
				f = 5 MHz	60		
			0°C to 70°C	f = 100 kHz	50		
				f = 5 MHz	60		
$k_{SVR}$ Supply voltage rejection ratio ( $\Delta V_{CC}/\Delta V_{IO}$ )	4	$\Delta V_{CC+} = \pm 0.5$ V, $\Delta V_{CC-} = \pm 0.5$ V, $R_{AB} = 0$	25°C	50	70	dB	
			0°C to 70°C	50			
$V_n$ Broadband equivalent input noise voltage	4	BW = 1 kHz to 10 MHz	25°C		3		$\mu$ V
$t_{pd}$ Propagation delay time	2	$\Delta V_O = 1$ V	25°C		7.5		ns
$t_r$ Rise time	2	$\Delta V_O = 1$ V	25°C		10.5		ns
$I_{sink(max)}$ Maximum output sink current		$V_{ID} = 1$ V, $V_O = 3$ V		3	4		mA
$I_{CC}$ Supply current		No load, No signal	25°C		18	24	mA
			0°C to 70°C			27	

†  $R_{AB}$  is the gain-adjustment resistor connected between gain-adjust pins A and B. If not specified for a particular parameter, its value is irrelevant to that parameter.

8961724 0108329 6T1

 **TEXAS  
INSTRUMENTS**

POST OFFICE BOX 655303 • DALLAS, TEXAS 75265

# TL592B DIFFERENTIAL VIDEO AMPLIFIER

SLFS001A - JUNE 1985 - REVISED APRIL 1988

## PARAMETER MEASUREMENT INFORMATION

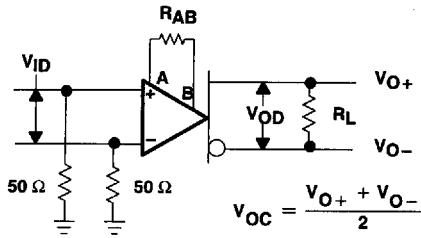

Figure 1

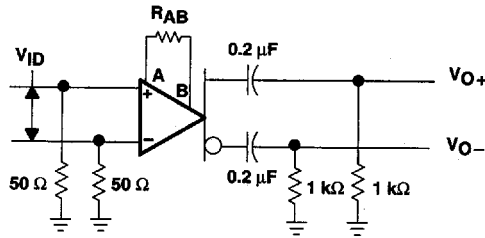

Figure 2

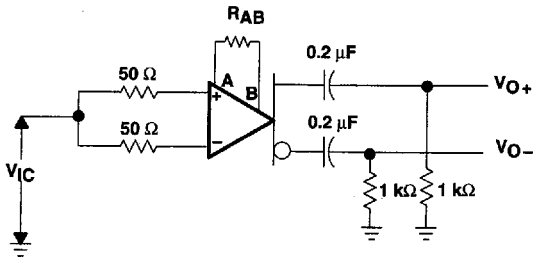

Figure 3

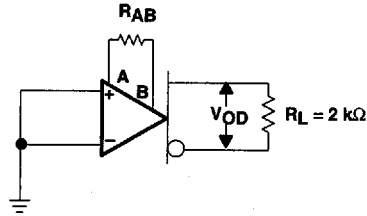

Figure 4

8961724 0108330 313

 **TEXAS  
INSTRUMENTS**

POST OFFICE BOX 655303 • DALLAS, TEXAS 75265

TYPICAL CHARACTERISTICS

LARGE-SIGNAL DIFFERENTIAL  
VOLTAGE AMPLIFICATION  
vs  
SUPPLY VOLTAGE

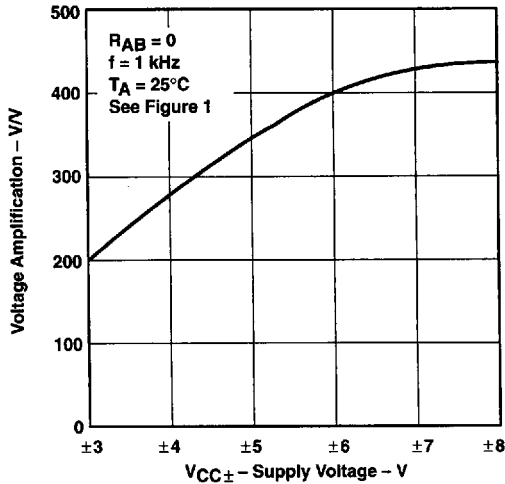

Figure 5

LARGE-SIGNAL DIFFERENTIAL  
VOLTAGE AMPLIFICATION  
vs  
GAIN-ADJUSTMENT RESISTANCE

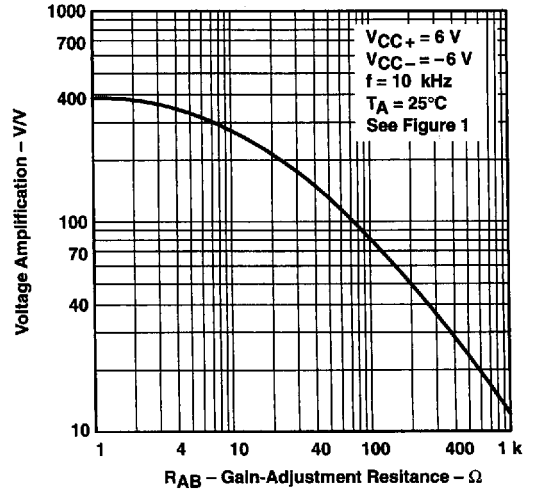

Figure 6

SUPPLY CURRENT  
vs  
SUPPLY VOLTAGE

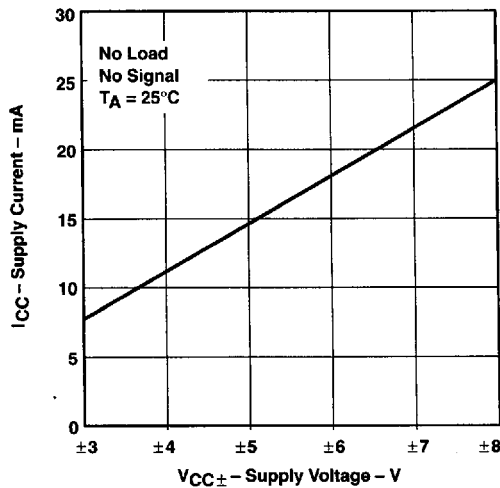

Figure 7

8961724 0108331 25T