

UG0557
User Guide
SmartFusion2 SoC FPGA Advanced Development Kit





Power Matters.™

Microsemi Corporate Headquarters

One Enterprise, Aliso Viejo,
CA 92656 USA

Within the USA: +1 (800) 713-4113

Outside the USA: +1 (949) 380-6100

Fax: +1 (949) 215-4996

Email: sales.support@microsemi.com

www.microsemi.com

© 2022 Microsemi Corporation. All rights reserved. Microsemi and the Microsemi logo are trademarks of Microsemi Corporation. All other trademarks and service marks are the property of their respective owners.

Microsemi makes no warranty, representation, or guarantee regarding the information contained herein or the suitability of its products and services for any particular purpose, nor does Microsemi assume any liability whatsoever arising out of the application or use of any product or circuit. The products sold hereunder and any other products sold by Microsemi have been subject to limited testing and should not be used in conjunction with mission-critical equipment or applications. Any performance specifications are believed to be reliable but are not verified, and Buyer must conduct and complete all performance and other testing of the products, alone and together with, or installed in, any end-products. Buyer shall not rely on any data and performance specifications or parameters provided by Microsemi. It is the Buyer's responsibility to independently determine suitability of any products and to test and verify the same. The information provided by Microsemi hereunder is provided "as is, where is" and with all faults, and the entire risk associated with such information is entirely with the Buyer. Microsemi does not grant, explicitly or implicitly, to any party any patent rights, licenses, or any other IP rights, whether with regard to such information itself or anything described by such information. Information provided in this document is proprietary to Microsemi, and Microsemi reserves the right to make any changes to the information in this document or to any products and services at any time without notice.

About Microsemi

Microsemi Corporation (Nasdaq: MSCC) offers a comprehensive portfolio of semiconductor and system solutions for aerospace & defense, communications, data center and industrial markets. Products include high-performance and radiation-hardened analog mixed-signal integrated circuits, FPGAs, SoCs and ASICs; power management products; timing and synchronization devices and precise time solutions, setting the world's standard for time; voice processing devices; RF solutions; discrete components; enterprise storage and communication solutions, security technologies and scalable anti-tamper products; Ethernet solutions; Power-over-Ethernet ICs and midspans; as well as custom design capabilities and services. Microsemi is headquartered in Aliso Viejo, California, and has approximately 4,800 employees globally. Learn more at www.microsemi.com.

Contents

1	Revision History	1
1.1	Revision 5.0	1
1.2	Revision 4.0	1
1.3	Revision 3.0	1
1.4	Revision 2.0	1
1.5	Revision 1.0	1
2	Introduction	2
2.1	Kit Contents	2
2.2	Block Diagram	2
2.3	Web Resources	3
2.4	Board Description	3
2.5	Board Key Components	4
3	Installation and Settings	6
3.1	Software Installation	6
3.2	Hardware Settings	6
3.2.1	Jumper Settings	6
3.2.2	LEDs	8
3.2.3	Test Points	9
3.3	Power Sources	9
4	Key Components Description and Operation	11
4.1	Powering Up the Board	11
4.2	Current Measurement	11
4.2.1	1.0 V or 1.2 V Current Sensing for Normal Operation	11
4.2.2	1.2 V Current Sensing for Flash*Freeze Mode	12
4.3	Memory Interface	12
4.3.1	DDR3 SDRAM	12
4.4	SerDes Interface	14
4.4.1	SERDES0 Interface	14
4.4.2	SERDES1 Interface	15
4.4.3	SERDES2 Interface	16
4.4.4	SERDES3 Interface	17
4.5	USB Interface	18
4.6	Marvell PHY (88E1340S)	18
4.7	Programming	19
4.8	FTDI Interface	20
4.9	System Reset	20
4.10	Clock Sources	21
4.10.1	50 MHz Clock Oscillator	21
4.10.2	100 MHz Clock Oscillator	22
4.11	User Interface	22
4.11.1	User LEDs	22
4.11.2	Push-Button Switches	23
4.11.3	Slide Switches - DPDT	24
4.11.4	DIP Switch - SPST	24
4.11.5	FMC Connectors	25

5	Pin List	41
6	Board Components Placement	42
7	Demo Design	45
8	Manufacturing Test	46
8.1	Programming M2S150-ADV-DEV-KIT	46
8.1.1	Validating Power Supply	46
8.1.2	Programming the FPGA Using Embedded FlashPro5	46
8.2	Running the Manufacturing Test	48
8.2.1	Setting Up Tera Term	48
8.2.2	Setting Up Jumpers	50
8.2.3	Running the Test	51

Figures

Figure 1	SmartFusion2 Advanced Development Kit Block Diagram	2
Figure 2	SmartFusion2 Advanced Development Board	4
Figure 3	Voltage Rails in SmartFusion2 Advanced Development Kit	10
Figure 4	Powering Up the Board	11
Figure 5	Core Power Measurement Circuitry	12
Figure 6	SmartFusion2 Memory Interface	13
Figure 7	SERDES0 Interface	14
Figure 8	SERDES1 Interface	15
Figure 9	SERDES2 Interface	16
Figure 10	SERDES3 Interface	17
Figure 11	USB Interface	18
Figure 12	Marvell PHY Interface	19
Figure 13	Programming Interface	19
Figure 14	System Reset Interface	21
Figure 15	50 MHz Clock Oscillator Interface	21
Figure 16	100 MHz Clock Oscillator Interface	22
Figure 17	LED Interface	23
Figure 18	Switches Interface	23
Figure 19	SPST Interface	24
Figure 20	Silkscreen Top View	43
Figure 21	Silkscreen Bottom View	44
Figure 22	PCIe Demo Design Window	45
Figure 23	FlashPro Window	47
Figure 24	New Project Window	47
Figure 25	Configuring the Device	48
Figure 26	Tera Term New Connection Window	48
Figure 27	Tera Term New Connection Window	49
Figure 28	Tera Term Serial Port Setup Window	49
Figure 29	Test Menu	51
Figure 30	Running RTC Test	51
Figure 31	RTC Test Passed	52
Figure 32	I2C Test Passed	52
Figure 33	DDR3 Memory Test Passed	52
Figure 34	SPI0 Memory Test Passed	53
Figure 35	SPI1 Memory Test Passed	53
Figure 36	USB Device Test Passed	53
Figure 37	SGMII Test	54
Figure 38	SGMII Test Passed	54
Figure 39	SGMII Debug Test	55
Figure 40	SGMII Debug Test	55
Figure 41	SGMII Debug Test	55
Figure 42	SGMII Debug Test Passed	56
Figure 43	SerDes Loopback Test	56
Figure 44	SerDes Loopback Test - Enabling PRBS Pattern for Lane 1	56
Figure 45	SerDes Loopback Passed	57

Tables

Table 1	Kit Contents	2
Table 2	SmartFusion2 Advanced Development Board Components	4
Table 3	Jumper Settings	6
Table 4	LEDs	8
Table 5	Test Points	9
Table 6	I/O Voltage Rails	9
Table 7	Programming Jumper Selection	20
Table 8	50 MHz Clock	21
Table 9	100 MHz Clock	22
Table 10	LEDs	22
Table 11	Push-Button Switches	23
Table 12	DIP Switches	24
Table 13	FMC HPC Connector (J30) Pinout	25
Table 14	FMC LPC Connector (J60) Pinout	36
Table 15	Jumper Settings for Manufacturing Test	50

1 Revision History

The revision history describes the changes that were implemented in the document. The changes are listed by revision, starting with the most current publication.

1.1 Revision 5.0

- In [Table 2](#), page 4, corrected the description of LEDs to mention that LEDs are active-low.
- In [Table 6](#), page 9, corrected the I/O Rail entry to VCCIO_HPC_VADJ for Bank6 and Bank8.

1.2 Revision 4.0

Information about the FTDI_JTAG_SEL signal was added. For more information, see [Programming](#), page 19.

1.3 Revision 3.0

PCIe edge card ribbon cable was removed from the kit contents. For more information, see [Kit Contents](#), page 2.

1.4 Revision 2.0

The following is a summary of the changes made in revision 2.0 of this document.

- Throughout the document, the part number was updated from M2S150-ADV-DEV-KIT-ES to M2S150-ADV-DEV-KIT (SAR 66855).
- Throughout the document, the device number was updated from M2S150T-1FCG1152ES to M2S150TS-1FCG1152 (SAR 66855).
- The MTD files link was updated. For more information, see [Manufacturing Test](#), page 46 (SAR 60671 and 68260).
- Pin details were updated. For more information, see [Validating Power Supply](#), page 46 (SAR 61171).
- Information about FMC connectors was updated. For more information, see [FMC Connectors](#), page 25 (SAR 67950).

1.5 Revision 1.0

Revision 1.0 was the first publication of this document.

2 Introduction

The RoHS-compliant SmartFusion[®]2 SoC FPGA Advanced Development Kit (M2S150-ADV-DEV-KIT) enables you to develop the following.

- Microprocessor applications
- Embedded ARM Cortex-M3 processor-based systems
- Motor control applications
- Industrial automation applications
- High-speed serial I/O applications
- Universal serial bus (USB) applications (with OTG support)

2.1 Kit Contents

The following table lists the contents of the SmartFusion2 Advanced Development Kit.

Table 1 • Kit Contents

Item	Quantity
SmartFusion2 Advanced Development Board with 150K LE M2S150TS-1FCG1152 device	1
USB A to Micro B cable	1
USB Micro A to A cable	1
USB A to Mini B cable	1
12 V/5 A power adapter	1

2.2 Block Diagram

The following figure is the block diagram of the SmartFusion2 Advanced Development Kit.

Figure 1 • SmartFusion2 Advanced Development Kit Block Diagram

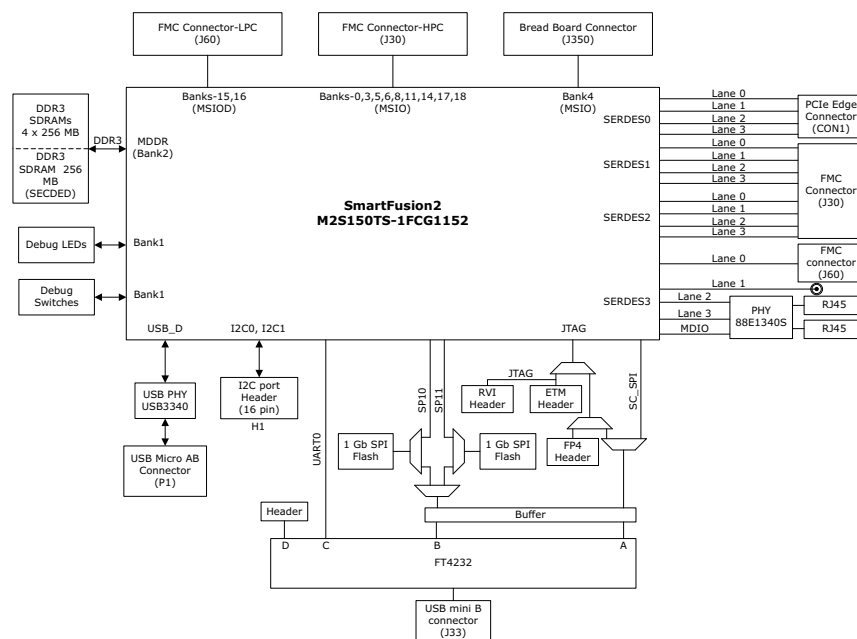

2.3 Web Resources

More information about the SmartFusion2 Advanced Development Kit is available at <http://www.microsemi.com/products/fpga-soc/design-resources/dev-kits/smartfusion2/smartfusion2-advanced-development-kit#overview>.

2.4 Board Description

M2S150-ADV-DEV-KIT offers a full-featured development board for SmartFusion2 SoC FPGAs. The board integrates the following features on a single chip.

- Reliable flash-based FPGA fabric
- 166 MHz ARM Cortex-M3 processor
- Advanced security processing accelerators
- Digital signal processing (DSP) blocks
- Static random-access memory (SRAM)
- Embedded non-volatile memory (eNVM)
- High-performance communication interfaces

The SmartFusion2 Advanced Development Board has several standard interfaces including:

- USB
- x4 serializer and deserializer (SerDes)
- DDR3 memory
- JTAG
- Inter-integrated circuit (I2C)
- Serial peripheral interface (SPI)
- Universal asynchronous receiver/transmitter (UART)
- Dual gigabit Ethernet

The SmartFusion2 memory management system supports 1 GB (4 × 256 MB) on-board DDR3 memory for data storage, 256 MB DDR3 memory for error detection and correction (ECC-SECDED), and 2 GB (2 × 1 GB) memory for SPI flash devices. The SerDes block can be accessed using the PCIe edge connector, high-speed sub-miniature version-A (SMA) connectors, or an on-board FPGA mezzanine card (FMC) low pin count (LPC) connector (J60). Unused MSIOD signals are routed to the J60 connector from the SmartFusion2 device. Unused MSIO signals are routed to another on-board FMC connector—HPC (J30), and although the bread board connector (J350) space available for Bank 4 (MSIO) pins.

The SmartFusion2 device can be programmed through embedded FlashPro5. The Advanced Development Kit has the current measurement feature (see [Current Measurement](#), page 11).

The following figure is a snapshot of the SmartFusion2 Advanced Development Board with its engineering silicon.

Figure 2 • SmartFusion2 Advanced Development Board

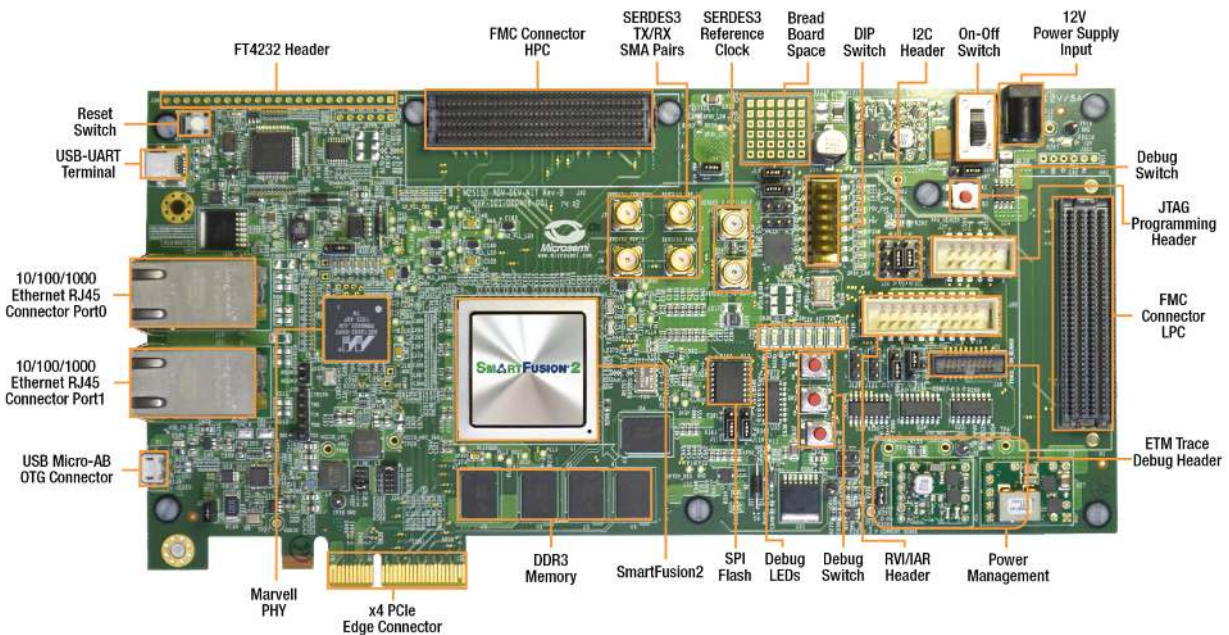

2.5 Board Key Components

The following table lists key components of the SmartFusion2 Advanced Development Board.

Table 2 • SmartFusion2 Advanced Development Board Components

Name	Description
SmartFusion2 FPGA	M2S150TS-1FCG1152 FPGA with a hard Cortex-M3 processor.
DDR3 synchronous dynamic random access memory (SDRAM)	4 × 256 MB (256 MB Micron DDR3 memories MT41K256M8DA-125 IT:K) for storing data, and 256 MB (1 × 256 MB Micron DDR3 memory MT41K256M8DA-125 IT:K) for storing ECC bits.
SPI flash	A 1-gigabit SPI flash (Micron N25Q00AA13GSF40G) connected to SPI port 0 of the SmartFusion2 microcontroller subsystem (MSS), and another 1-gigabit SPI flash (Micron N25Q00AA13GSF40G) connected to the SmartFusion2 fabric.
Ethernet	Two RJ45 connectors (Ethernet jacks with built-in magnetics) interfacing with a Marvell 10/100/1000 BASE-T physical layer (PHY) chip—88E1304S—in Serial Gigabit Media Independent Interface (SGMII) mode. The Marvell PHY device, in turn, interfaces with the Ethernet port of the SmartFusion2 MSS (on-chip MAC and external PHY).
RVI header	RVI header for application programming and debugging using Keil ULINK or IAR J-Link.
Embedded FlashPro5	Embedded FlashPro5 for programming and debugging the SmartFusion2 FPGA using Microsemi tools.
Future Technology Devices International (FTDI) programmer	FTDI programmer interface (J33) to program the external SPI flash. An FTDI chip is also used to change the JTAG_SEL signal (<i>high</i> or <i>low</i>) remotely for switching between the RVI header and JTAG mode.

Table 2 • SmartFusion2 Advanced Development Board Components (continued)

Embedded Trace Macro (ETM) cell header	ETM header for debugging.
PCI Express (PCIe) edge connector	PCIe edge connector with four lanes.
Light-emitting diodes (LEDs)	Eight active-low LEDs connected to some of the user I/Os for debugging.
Push-button reset	Push-button system reset for the SmartFusion2 device.
Push-button switches	Four push-button switches for testing and navigation.
FMC HPC connector (J30)	High pin count FMC header to connect the external daughter boards. Connector array socket 400 pins (40 × 10), 1.27 mm pitch. Unused MSIO pins routed from the SmartFusion2 device to the J30 connector.
FMC LPC connector (J60)	Low pin count FMC header to connect the external daughter boards. Connector array socket 160 pins (40 × 4), 1.27 mm. Unused MSIOD pins routed from the SmartFusion2 device to the J60 connector.
USB interface	USB Micro-AB connector, interfacing with the high speed USB2.0 ULPI transceiver chip USB3320, which, in turn, interfaces with USB-D port of the SmartFusion2 MSS.
DS1818 3.3V EconoReset	A simple three-pin voltage monitor and power-on reset that holds reset for 150 ms for stabilization after power returns to tolerance.
OSC-100	100 MHz clock oscillator with differential output.
OSC-125	125 MHz clock oscillator with differential output.
OSC-50	50 MHz clock oscillator.
OSC-32	32.768 KHz low-power oscillator.
FT4232H	USB-to-quad serial ports in various configurations.
TPS3808G09DBVR	Supervisory circuit that monitors system voltage of 0.9 V, asserting an open-drain reset signal when the sense voltage drops below a preset threshold or when the manual reset (MR) pin drops to a logical low.
I2C port header	16-pin header available for I2C0 and I2C1 interfaces of the SmartFusion2 device.

3 Installation and Settings

This section provides information about the software and hardware settings for the SmartFusion2 Advanced Development Kit.

3.1 Software Installation

Download and install the Microsemi Libero® SoC software v11.4 or later from the Microsemi website, and register for a free Gold license to the software. The Libero SoC v11.4 or later installer has FlashPro5 drivers. For instructions on how to install Libero SoC and SoftConsole, see [Libero Software Installation and Licensing Guide](#).

For instructions on how to download and install Microsemi DirectCores, SGCores, and driver firmware cores, which must be installed on the PC where Libero SoC is installed, see [Installing IP Cores and Drivers User Guide](#).

The SmartFusion2 FPGA is supported by the latest IAR Embedded Workbench from IAR Systems for ARM IP. It is also supported by the latest Keil MDK-ARM Microcontroller Advanced Development Kit.

3.2 Hardware Settings

This section provides information about default jumper settings, switches, LEDs, and DIP switches for the SmartFusion2 Advanced Development Kit.

3.2.1 Jumper Settings

Connect the jumpers with the default settings specified in the following table to evaluate the pre-programmed demo design.

Table 3 • Jumper Settings

Jumper	Description	Pin	Default Settings
Power Supply			
J123	Jumper to select a core voltage (VDD_REG) of 1.0 V or 1.2 V.	Pin 1-2 for 1.0 V.	Open
		Pin 2-3 for 1.2 V.	Close
J353	Jumper to select a core voltage (VCCIO_HPC_VADJ) of 3.3 V, 2.5 V, 1.8 V, 1.5 V, or 1.2V.	Pin 1-2 for 3.3 V.	Closed
		Pin 3-4 for 2.5 V.	Open
		Pin 5-6 for 1.8 V.	Open
		Pin 7-8 for 1.5 V.	Open
		Pin 9-10 for 1.2 V.	Open
J354	Jumper to select a core voltage (VCCIO_LPC_VADJ) of 2.5 V, 1.8 V, 1.5 V, or 1.2V.	Pin 1-2 for 2.5 V.	Closed
		Pin 3-4 for 1.8 V.	Open
		Pin 5-6 for 1.5 V.	Open
		Pin 7-8 for 1.2 V.	Open
J116	Jumpers to select either SW7 input or signal ENABLE_FT4232 from FT4232H chip.	Pin 1-2 for SW7 switch selection.	Closed
		Pin 2–3 for Enable_FT4232 signal control.	Open

Table 3 • Jumper Settings (continued)

Clocks			
J10	Jumper to select switch-side MUX inputs of A or B to the line side.	Pin 1-2 (Input A to the line side) for external clock required to source the line side through FMC connector.	Open
		Pin 2-3 (Input B to the line side) for external clock required to source the line side through SMA connectors.	Open
J9	Jumper to select the output-enable control for the line side outputs.	Pin 1-2 (line-side output enabled).	Open
		Pin 2-3 (line-side output disabled).	Open
J8	Jumper to select the output-enable control for the line side outputs.	Pin 1-2 (line-side output enabled).	Closed
		Pin 2-3 (line-side output disabled).	Open
J11	Jumper to select switch-side MUX inputs of A or B to the line side.	Pin 1-2 (Input A to the line side), that is, on-board 125 MHz differential clock oscillator output is routed to line side.	Closed
		Pin 2-3 (Input B to the line side), that is, on-board 100 MHz differential clock oscillator output is routed to line side.	Open
Marvell PHY			
J14	Jumper to select either PHY_CONFIG1 or M2S_PHY_CONFIG1 for global hardware configuration (CONFIG[1]).	Pin 1-2 CONFIG [1] connects to P2_LED[2] pin of 88E1340S.	Open
		Pin 2-3 CONFIG [1] connects to SmartFusion2 J8 pin (MSIO80NB3).	Open
J15	Jumper to short AC test points for debugging. It is recommended not to connect this jumper; refer to the Marvell PHY Datasheet.	Two-pin header.	Open
J23	Jumper to provide the VBUS supply to USB when used in host mode.	Two-pin header.	Open
Programming			
J32	JTAG selection jumper to select RVI header or FP4 header for application debug.	Pin 1-2 FP4 for SoftConsole/FlashPro.	Closed
		Pin 2-3 RVI for Keil ULINK or IAR J-Link.	Open
		Pin 2-4 for JTAG_SEL pin to DD1 signal of FT4232H chip.	Open
J121	Jumper to select FTDI JTAG or SPI slave programming.	Pin 1-2 for FTDI JTAG programming.	Closed
		Pin 2-3 for FTDI SPI slave programming.	Open
J124	Jumper to select JTAG programming via FP4 or FTDI.	Pin 1-2 for JTAG programming via FTDI.	Open
		Pin 2-3 for JTAG programming via FP4.	Closed
J125	Jumper to select FTDI SPI-0 or FTDI SPI-1 slave programming	Pin 1-2 for FTDI SPI-1 slave programming.	Open
		Pin 2-3 for FTDI SPI-0 slave programming.	Open

Table 3 • Jumper Settings (continued)

J118	Jumper to select programming SPI-0 flash through FTDI SPI-0 (Port-B) or SmartFusion2 SPI-0.	Pin 1-2 for programming SPI-0 flash via SmartFusion2 SPI-0.	Closed
		Pin 2-3 for programming SPI-0 flash via FTDI SPI-0 (Port-B). J125 pin 2-3 must be shorted.	Open
J119	Jumper to select programming SPI-1 flash through FTDI SPI (Port-B) or SmartFusion2 SPI-1.	Pin 1-2 for programming SPI-1 flash via SmartFusion2 SPI-1.	Closed
		Pin 2-3 for programming SPI-1 flash via FTDI SPI (Port-B). J125 pin 1-2 must be shorted.	Open

For locations of various jumpers and test points on the SmartFusion2 Advanced Development Board, see [Figure 20](#), page 43 and [Figure 21](#), page 44.

3.2.2 LEDs

The following table lists the power supply and Ethernet LEDs.

Table 4 • LEDs

LED	Description
DS26	Indicates USB_5V supply
DS18	Indicates 0P75V_REG supply
DS19	Indicates 1P5V_REG supply
DS20	Indicates VDD_REG supply
DS21	Indicates 2P5V_LDO supply
DS22	Indicates VCCIO_LPC_VADJ supply
DS23	Indicates VCCIO_HPC_VADJ supply
DS24	Indicates 1P0V_PHY supply
DS25	Indicates 1P8V supply
DS28	Indicates 3P3V_LDO supply
DS17	Indicates 5P0V supply
DS29	Indicates 3P3V supply
DS16	Indicates 12P0V supply
DS27	Indicates VSS_BUS supply
DS8	Indicates that DS8 is connected to parallel LED output port 0 (P0_LED[0]) of Marvell PHY
DS9	Indicates that DS9 is connected to parallel LED output port 0 (P0_LED[2]) of Marvell PHY
DS10	Indicates that DS10 is connected to parallel LED output port 0 (P0_LED[3]) of Marvell PHY
DS14	Indicates that DS14 is connected to parallel LED output port 1 (P1_LED[0]) of Marvell PHY
DS13	Indicates that DS13 is connected to parallel LED output port 1 (P1_LED[1]) of Marvell PHY
DS12	Indicates that DS12 is connected to parallel LED output port 1 (P1_LED[2]) of Marvell PHY
DS11	Indicates that DS11 is connected to parallel LED output port 1 (P1_LED[3]) of Marvell PHY

3.2.3 Test Points

The following table lists USB, ground, and other test points.

Table 5 • Test Points

Test Point	Description
TP20, TP33, TP16	GND
TP7	VDD_REG
TP12	12 V
TP11	5 V
TP4	3.3 V
TP29	VCCIO_HPC_VADJ
TP28	VCCIO_LPC_VADJ
TP30	3P3V_LDO
TP31	2P5V_LDO
TP9	1.5 V
TP10	0.75 V
TP14	1.8 V
TP27	VDDIO for the USB device
TP24	PHY 1.0 V

3.3 Power Sources

The following table lists the key power supplies required for normal operation of the SmartFusion2 Advanced Development Kit.

Table 6 • I/O Voltage Rails

SmartFusion2 Bank	I/O Rail	Voltage
Bank0	VCCIO_HPC_VIO_B_M2S	3.3 V, 2.5 V, 1.8 V, 1.5 V, or 1.2 V
Bank1	2P5V_LDO	2.5 V
Bank2	1P5V_REG	1.5 V
Bank3	3P3V	3.3 V
Bank4	3P3V	3.3 V
Bank5	VCCIO_HPC_VIO_B_M2S	3.3 V, 2.5 V, 1.8 V, 1.5 V, or 1.2 V
Bank6	VCCIO_HPC_VADJ	2.5 V, 1.8 V, 1.5 V, or 1.2 V
Bank7	3P3V	3.3 V
Bank8	VCCIO_HPC_VADJ	2.5 V, 1.8 V, 1.5 V, or 1.2 V
Bank9	2P5V_LDO	2.5 V
Bank10	2P5V_LDO	2.5 V
Bank11	VCCIO_HPC_VADJ	3.3 V, 2.5 V, 1.8 V, 1.5 V, or 1.2 V
Bank12	2P5V_LDO	2.5 V
Bank13	2P5V_LDO	2.5 V
Bank14	VCCIO_HPC_VADJ	3.3 V, 2.5 V, 1.8 V, 1.5 V, or 1.2 V

Table 6 • I/O Voltage Rails (continued)

Bank15	VCCIO_LPC_VADJ	2.5 V, 1.8 V, 1.5 V, or 1.2 V
Bank16	VCCIO_LPC_VADJ	2.5 V, 1.8 V, 1.5 V, or 1.2 V
Bank17	VCCIO_HPC_VADJ	3.3 V, 2.5 V, 1.8 V, 1.5 V, 1.2 V
Bank18	VCCIO_HPC_VADJ	3.3 V, 2.5 V, 1.8 V, 1.5 V, or 1.2 V
VDD	VDD_REG	1.2 V or 1.0 V
VPP	3P3V_VPP	3.3 V
VREF1	VREF1	0.75 V
VREF2	0P75V_VTT_REF	0.75 V
SERDES_x_PLL_VDDA	PLL_SERDESx_VDDA	3.3 V
SERDES_x_L01_VDDAPLL	SERDESx_VDDPLL	2.5 V
SERDES_x_VDD	VDD_REG	1.2 V or 1.0 V

The following figure shows the voltage rails (12 V, 5 V, 3.3 V, 2.5 V, 1.8 V, 1.5 V, 1.2 V, 1.0 V, and 0.75 V) available in the SmartFusion2 Advanced Development Kit.

Figure 3 • Voltage Rails in SmartFusion2 Advanced Development Kit

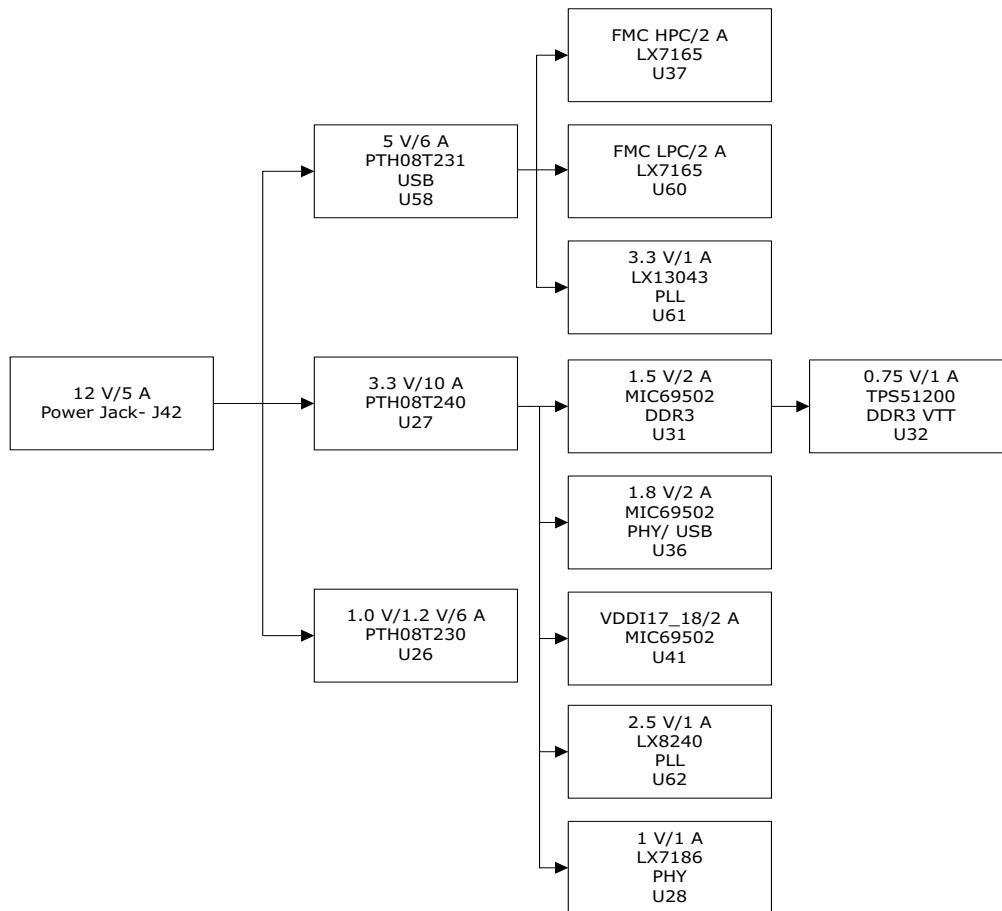

4 Key Components Description and Operation

This section describes the key component interfaces of the SmartFusion2 Advanced Development Kit. For device datasheets, go to <http://www.microsemi.com/products/fpga-soc/design-resources/dev-kits/smartfusion2-kits>.

4.1 Powering Up the Board

The SmartFusion2 Advanced Development Board is powered using a 12 V external DC jack (12P0V_Ext), as shown in the following figure.

To power up the board:

1. Connect the 12 V power supply brick to the **J42** jumper to supply power to the board.
2. Switch ON the **SW7** power supply switch.

Figure 4 • Powering Up the Board

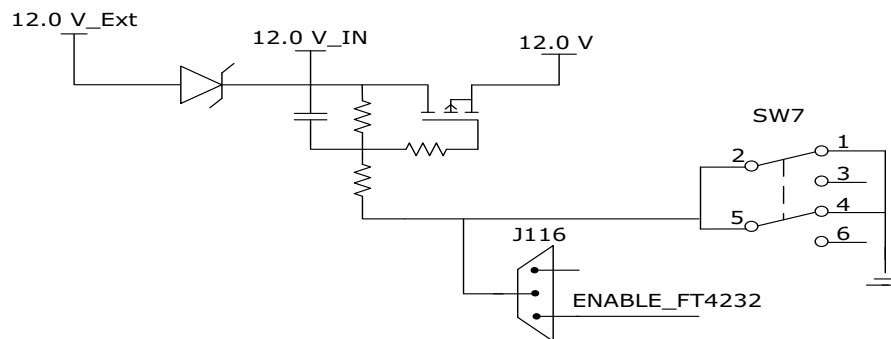

4.2 Current Measurement

This section provides information about current sensing in various modes.

4.2.1 1.0 V or 1.2 V Current Sensing for Normal Operation

For applications that require current measurement, high-precision operational amplifier circuitry (U59 with gain 100) is provided on the board to measure the output voltage at the **TP17** test point.

The following steps describe how to measure the core power.

1. Measure the output voltage (V_{OUT}) at TP17.
2. $I = (V_{OUT}/5)$.
3. Core power consumed (P) = $(1.2 \text{ V}) \times I$.

For example, when the voltage measured across TP17 is 0.5 V, the core power consumed is 0.12 W.

The following figure shows the on-board core power measurement circuitry.

Figure 5 • Core Power Measurement Circuitry

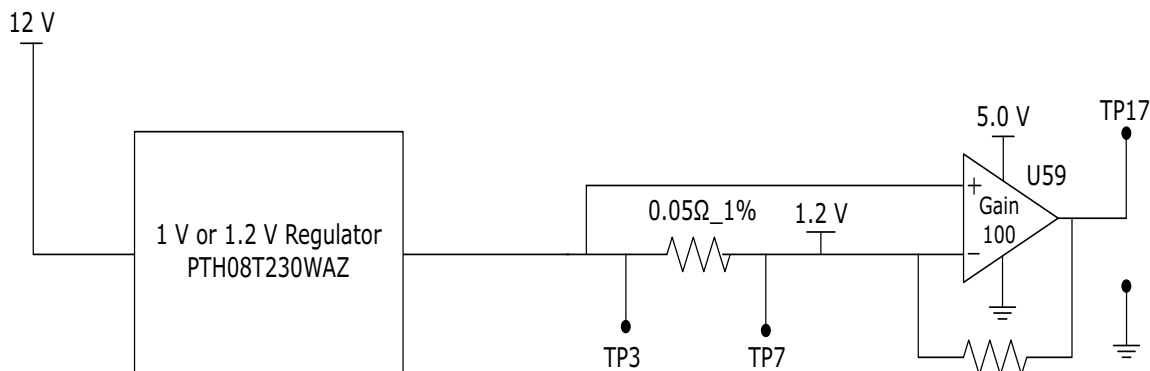

4.2.2 1.2 V Current Sensing for Flash*Freeze Mode

The SmartFusion2 device consumes very less power in Flash*Freeze mode. The voltage across the sense resistor (0.05 Ω) must be measured directly using a precision digital multimeter that can read sub-millivolts. The **TP16** and **TP17** test points can be used to directly measure the voltage across the 1.2 V sense resistor.

To convert the voltage measured across a sense resistor to power, use the following equation.

$$\text{Power} = \left(\frac{\text{voltage_in_millivolts}}{0.05} \right) \times 1.2$$

Note: Accuracy is ± 10%.

4.3 Memory Interface

Dedicated I/Os for MSS DDR and fabric DDR are available in the SmartFusion2 device.

4.3.1 DDR3 SDRAM

Four chips with 256 MB DDR3 memory are provided in the SmartFusion2 device as flexible volatile memory for user applications. Additionally, one chip with 256 MB DDR3 memory is provided for ECC. You can enable the SECDED feature using ECC. The DDR3 interface is implemented in Bank2.

DDR3 SDRAM specifications for the SmartFusion2 device are as follows.

- MT46H32M16LF: 32 Meg × 8 × 8 banks
- Density: 256 MB
- Clock rate: 800 MHz
- Data rate: DDR3 - 1600
- Total capacity: 1 GB across four chips

The following figure shows the SmartFusion2 memory interface.

Figure 6 • SmartFusion2 Memory Interface

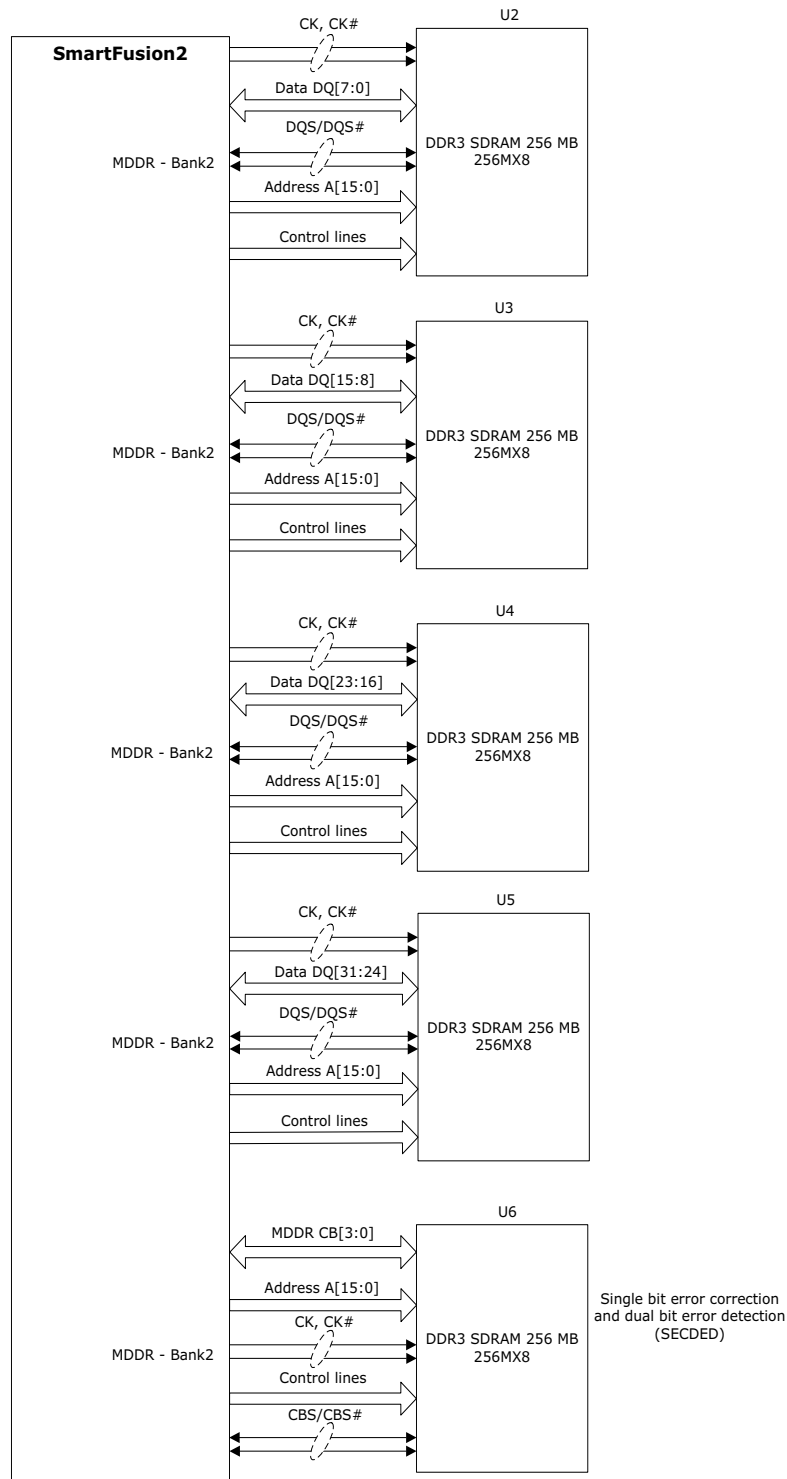

For more information, see the Board Level Schematics document (provided separately).

4.4 SerDes Interface

The SmartFusion2 Advanced Development Kit has x4 SerDes interfaces. The SerDes block can be accessed using the PCIe edge connector, high-speed sub-miniature version-A (SMA) connectors, and/or an on-board FPGA mezzanine card (FMC) low pin count (LPC) connector (J60).

Note: All SerDes TXD pairs (SERDES0, SERDES1, SERDES2, and SERDES3) are capacitively coupled to the SmartFusion2 device. Serial AC-coupling capacitors are used to provide common-mode voltage independence.

For more information, see the Board Level Schematics document (provided separately).

4.4.1 SERDES0 Interface

The SERDES0 interface (Lane 0, 1, 2, or 3) is directly routed to the PCIe connector. The SerDes reference clocks are routed as follows.

- SERDES0 reference clock 0 is directly routed from the PCIe connector to the SmartFusion2 device.
- SERDES0 reference clock 1 is routed from the 100 MHz differential clock source (LVDS clock oscillator) through resistors.

The following figure shows the SERDES0 interface of the SmartFusion2 Advanced Development Board.

Figure 7 • SERDES0 Interface

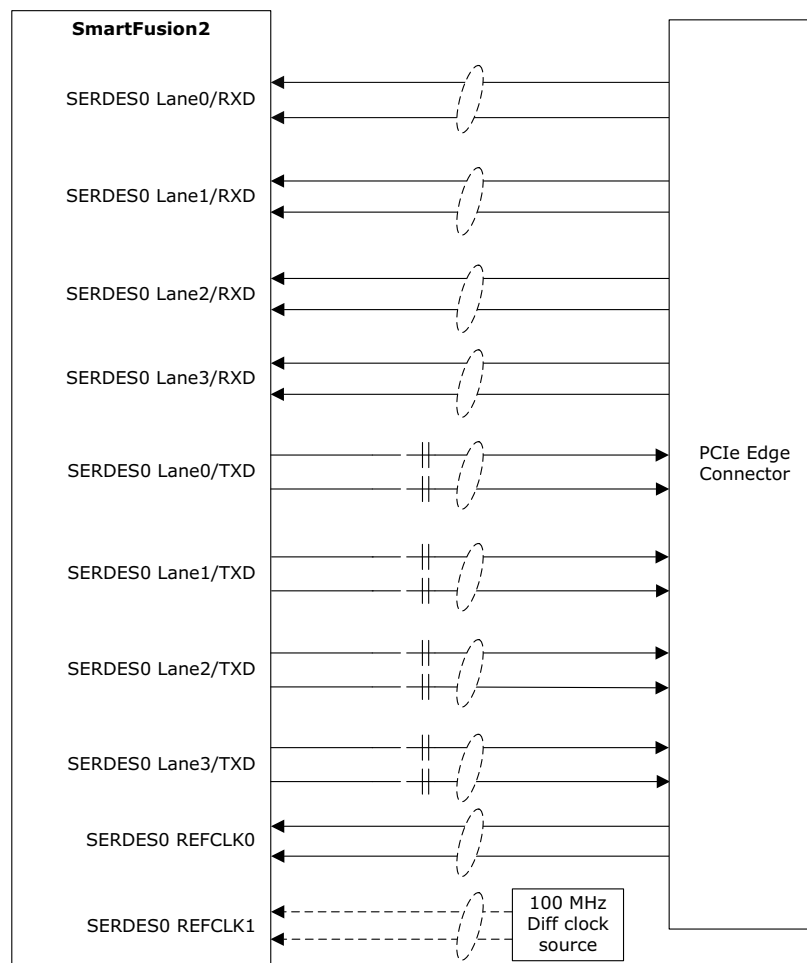

Note: Mount R977 and R978 to source the clock from 100 MHz differential oscillator to the SERDES0 REFCLK1.

4.4.2 SERDES1 Interface

The SERDES1 interface (Lane 0, 1, 2, or 3) is routed to the FMC connector. The SerDes reference clocks are routed as follows.

- SERDES1 reference clock 0 is routed from the FMC connector.
- SERDES1 reference clock 1 is routed from the FMC connector through the clock buffer. The output of the clock buffer is additionally routed to SmartFusion2 Advanced Development Kit board pins AF18 and AG18.

The following figure shows the SERDES1 interface of the SmartFusion2 Advanced Development Board.

Figure 8 • SERDES1 Interface

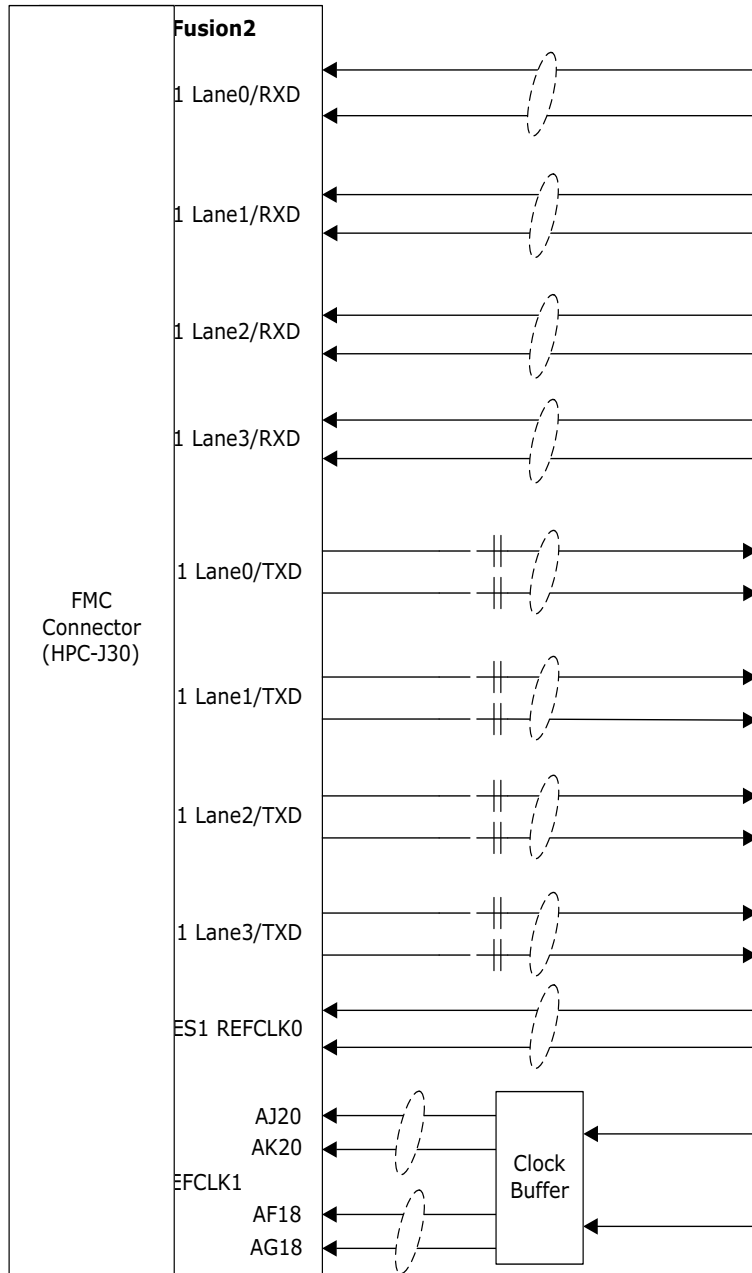

4.4.3 SERDES2 Interface

The SERDES2 interface (Lane 0, 1, 2, or 3) is routed to the FMC connector. The SerDes reference clocks are routed as follows.

- SERDES2 reference clock 0 is routed from the FMC connector.
- SERDES2 reference clock 1 is routed from the FMC connector through the clock buffer. The output of the clock buffer is additionally routed to SmartFusion2 Advanced Development Kit board pins AE17 and AF17.

The following figure shows the SERDES2 interface of the SmartFusion2 Advanced Development Board.

Figure 9 • SERDES2 Interface

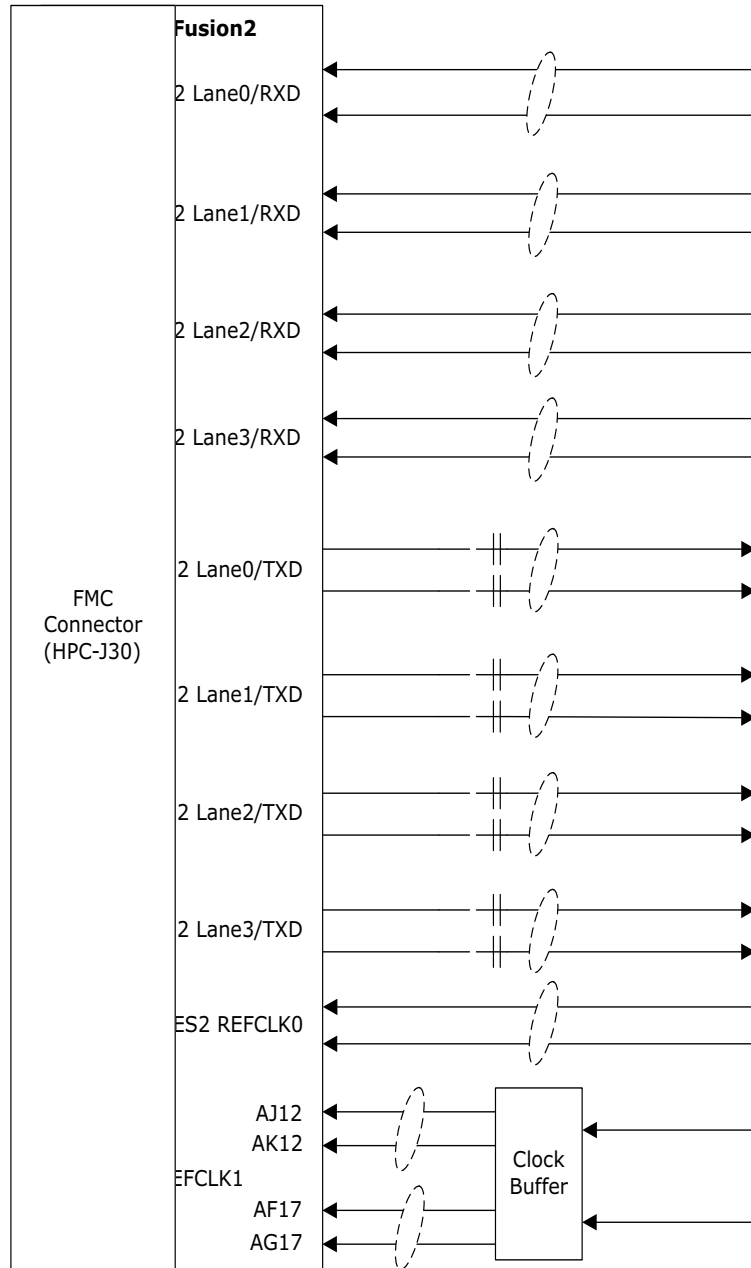

4.4.4 SERDES3 Interface

The SERDES3 lanes are connected as follows.

- Lane 0 is connected to the FMC connector.
- Lane 1 is connected to the SMA connectors.
- Lanes 2 and 3 are connected to the Marvell PHY device ports 0 and 1, respectively.
- SERDES3 reference clock 0 is connected from FMC connector or SMA connector through MUX.
- SERDES3 reference clock 1 is connected from 125 MHz or 100 MHz through MUX.

The following figure shows the SERDES3 interface of the SmartFusion2 Advanced Development Board.

Figure 10 • SERDES3 Interface

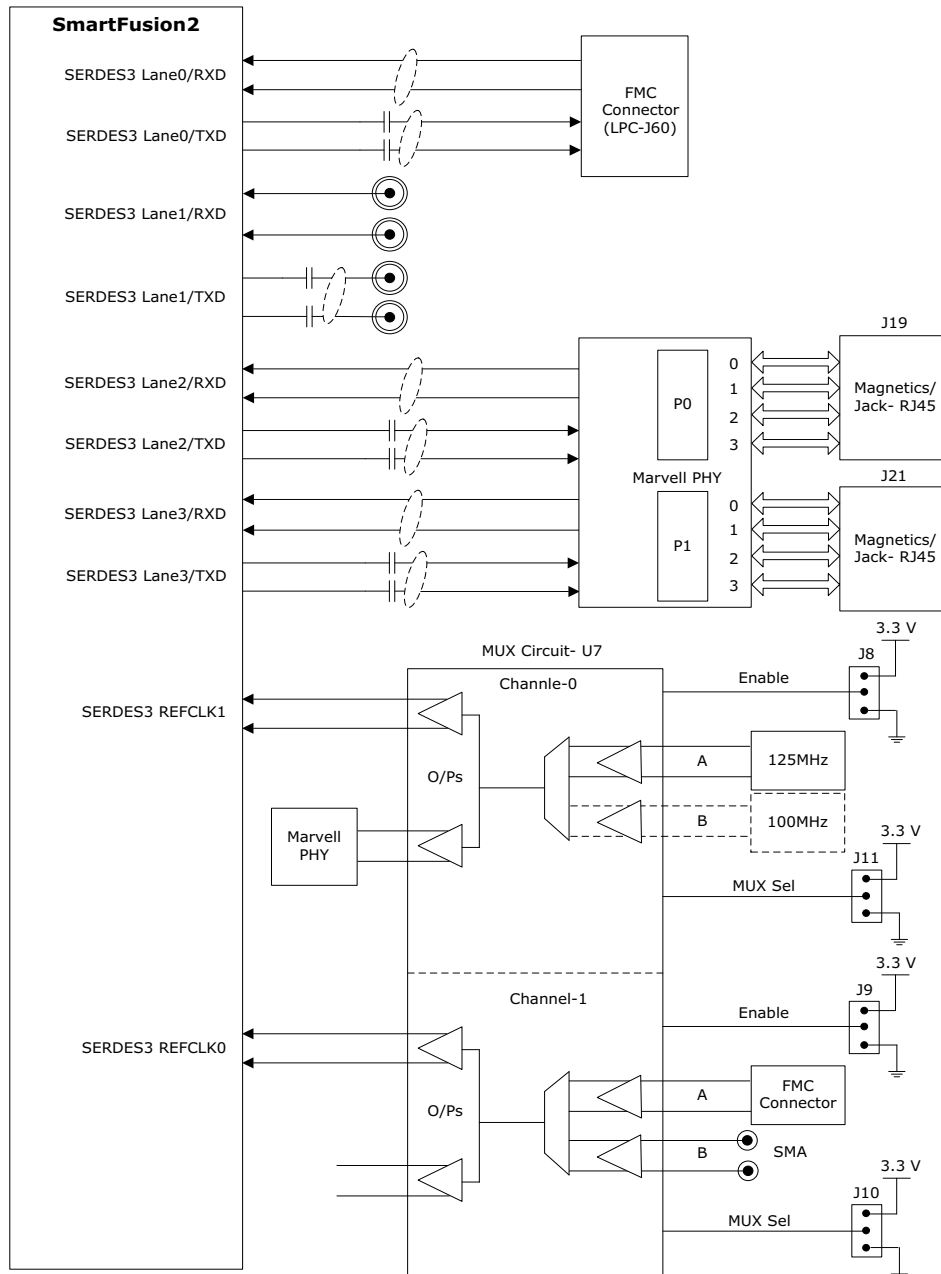

4.5 USB Interface

The following figure shows the USB interface of the SmartFusion2 Advanced Development Board. The SMSC USB3320 shown in the following figure is a high-speed USB 2.0 ULPI transceiver that provides the industry standard UTMI+ low pin interface to connect the USB transceiver to the link. CPEN (shown in the figure) is the external 5 V supply enable pin that controls the external VBUS power switch.

In the SmartFusion2 Advanced Development Kit, the USB interface can operate in host, device, and OTG modes. To use device mode, J23 can either be in open or shorted. To use host or OTG mode, pins 1 and 2 of the **J23** jumper must be closed.

Figure 11 • USB Interface

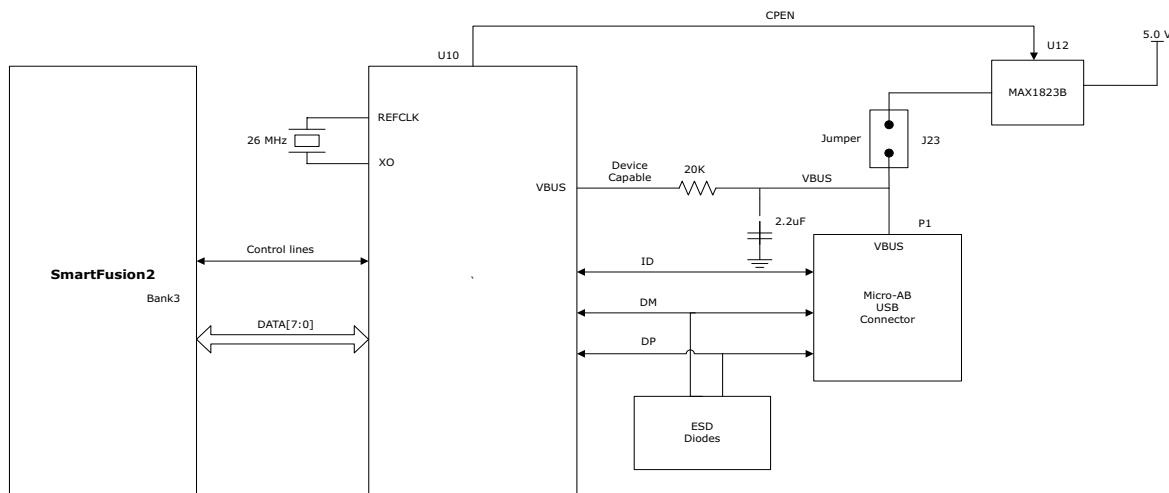

For more information, see the Board Level Schematics document (provided separately).

4.6 Marvell PHY (88E1340S)

The SmartFusion2 Advanced Development Kit uses the on-board Marvell Alaska PHY device 88E1340S for Ethernet communications at 10 or 1000 Mbps. The device has four independent gigabit Ethernet transceivers; however, the board uses only two of these transceivers. Each transceiver performs all the PHY functions for 100BASE-TX and 1000BASE-T full-duplex or half-duplex Ethernet on a CAT5 twisted-pair cable. The PHY device is connected to a user-provided Ethernet cable through an RJ45 connector with built-in magnetics.

Device 88E1340S supports Quad SGMII for direct connection to a SmartFusion2 chip. It is configured through the CONFIG [3:0] and CLK_SEL [1:0] pins.

The CLK_SEL [1:0] pin is used to select the reference clock input. On the board, the status of the CLK_SEL0 pin is *high* and the status of the CLK_SEL1 pin is *low*. REF_CLK is a 125 MHz reference differential clock input (Y11). It consists of LVDS differential inputs with a 100 Ω differential internal termination resistor.

Key features of Marvell PHY 88E1340S are as follows.

- RCLK: Gigabit recovered clock
- SCLK: 25 MHz synchronous input reference clock
- Expected reference clock (REF_CLK) specifications:
 - Voltage level: 3.3 (\pm 0.3) V
 - Differential LVDS
 - Symmetry: 50% (\pm 10%)
 - Rise/fall time: Maximum 1 ns @ 20% to 80% of supply (3.3 V)
 - Output voltage levels: 0 = 0.90 minimum, 1.10 typical; 1 = 1.43 typical, 1.60 maximum
 - Differential output voltage: 247 mV minimum, 454 mV maximum

The following figure shows the SmartFusion2 Marvell PHY interface.

Figure 12 • Marvell PHY Interface

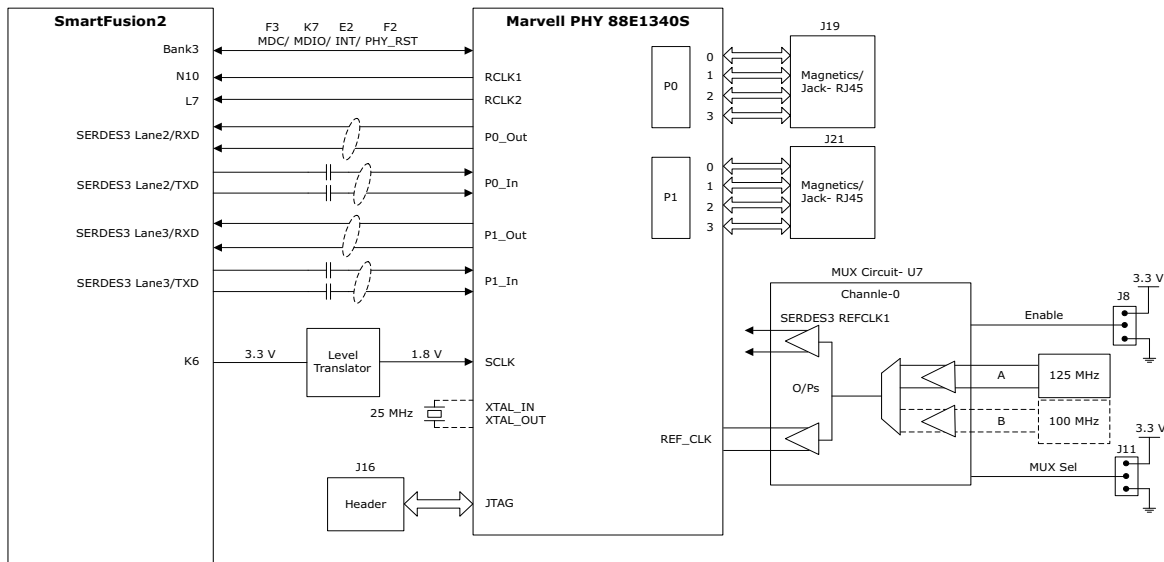

For more information, see the Board Level Schematics document (provided separately).

4.7 Programming

SmartFusion2 SoC FPGAs support multiple programming interfaces and can address a wide range of platform requirements. A SmartFusion2 device can be programmed through the JTAG and SPI interfaces.

The dedicated programming SPI port can operate in SPI slave or SPI master modes.

For more information, see [SmartFusion2 and IGLOO2 Programming User Guide](#).

The following figure shows the programming interface of the SmartFusion2 Advanced Development Board.

Figure 13 • Programming Interface

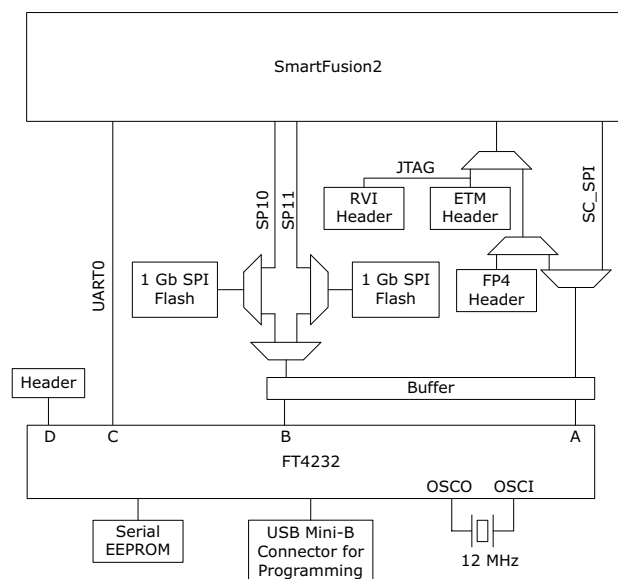

JTAG_SEL: The JTAG state machine is multiplexed with the CM3 debug port. JTAG_SEL is used to switch between JTAG programming (high) and CM3 debug (low). When using the CM3 debug port, an option is available to switch to serial wire debug port.

RVI Header: A 10 × 2 RVI header is provided on the board for debugging. This header allows plugging in the Keil ULINK debugger or IAR J-Link debugger to easily debug or configure the Cortex-M3 processor during board power-up.

FTDI_JTAG_SEL: The SmartFusion2 device on the Advanced Development Kit can be programmed either using the JTAG header or the RVI header. FTDI_JTAG_SEL is used to switch between programming the device using the JTAG header (high) or the RVI header (low).

FLASH_GOLDEN_N: This signal is always tied high to the 3.3V VCCIO_HPC_VADJ supply. It indicates that the SPI is in slave mode.

FlashPro4 Programming Header: The SmartFusion2 device on this Advanced Development Kit can be programmed using a FlashPro4 programmer. In addition, SoftConsole uses FlashPro4 for software debugging.

The following table lists jumpers to be selected for various types of programming.

Table 7 • Programming Jumper Selection

J121	J124	J125	J32	Function
X	X	X	L	IAR debugging
X	L	X	H	FP4 JTAG programming
H	H	X	H	FTDI JTAG programming (embedded FlashPro5 programming)
L	X	X	H	FTDI SPI slave programming
X	X	L	X	FTDI SPI-0 programming
X	X	H	X	FTDI SPI-1 programming

For more information, see the Board Level Schematics document (provided separately).

4.8 FTDI Interface

The FT4232H chip is a USB 2.0 high-speed (480 Mbps) to UART/MPSSE interface with the following key features.

- Single-chip USB-to-quad serial ports in various configurations
- Entire USB protocol handled on the chip without requiring USB-specific firmware programming
- USB 2.0 high-speed (480 Mbps) and full-speed (12 Mbps) compatibility
- Two MPSSEs on channel A and channel B to simplify synchronous serial protocol (USB to JTAG, I2C, SPI, or bit-bang) design
- Fully assisted hardware handshaking and X-On/X-Off software handshaking
- +1.8 V (chip core) and +3.3 V I/O interfacing with +5 V tolerance

4.9 System Reset

The M2S_RSTB signal (active-low) is generated by the **SW6** push-button switch, or by the U21 (DS1818) or U22 (TPS3808G09) chips. DEVRST_N is an input-only reset pad that allows assertion of a full reset to the chip at any time.

DS1818 maintains reset till 150 milliseconds after the 3.3 V supply returns to intolerance. The TPS3808G09DBVR device monitors the voltage at the VDD_REG terminal. If the voltage at this terminal sense-drops below the threshold voltage of 0.9 V, the M2S_RSTB signal is asserted.

The following figure shows the system reset interface of the SmartFusion2 Advanced Development Board.

Figure 14 • System Reset Interface

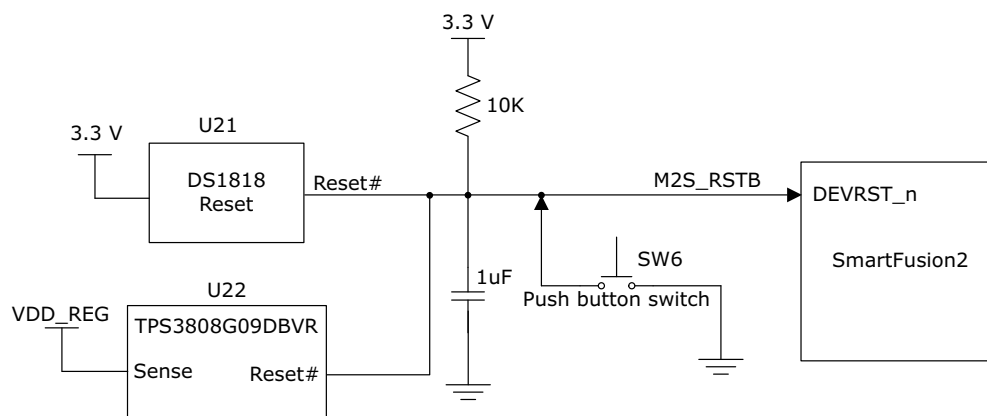

For more information, see the Board Level Schematics document (provided separately).

4.10 Clock Sources

This section provides information about the clock sources available in the SmartFusion2 Advanced Development Kit.

4.10.1 50 MHz Clock Oscillator

A 50 MHz clock oscillator with an accuracy of +/-50 ppm is available on the board. This clock oscillator is connected to the FPGA fabric to provide a system reference clock.

An on-chip SmartFusion2 PLL can be configured to generate a wide range of high-precision clock frequencies.

The following table provides package and pin details of the 50 MHz oscillator.

Table 8 • 50 MHz Clock

SmartFusion2 Advanced Development Kit Pin Name	SmartFusion2 Package Number	SmartFusion2 Device Pin Name
50MHZ_SECLK_B4_P1	P1	MSIO39PB4/CCC_NE0_CLKI1

The following figure shows the 50 MHz clock oscillator interface.

Figure 15 • 50 MHz Clock Oscillator Interface

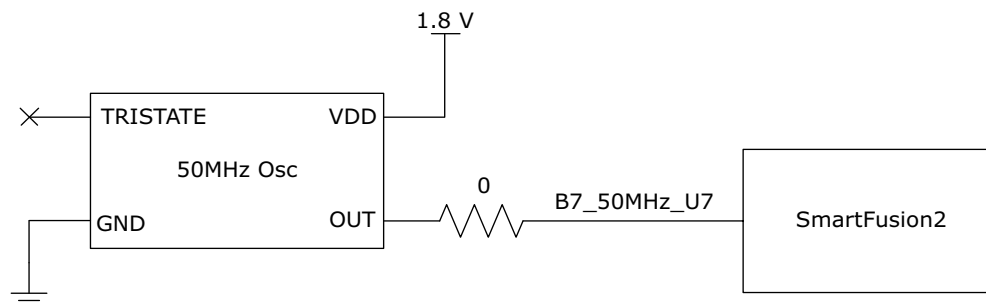

For more information, see the Board Level Schematics document (provided separately).

4.10.2 100 MHz Clock Oscillator

A 100 MHz LVDS clock oscillator operating at 3.3 V with an accuracy of +/-50 ppm is available on the board. This clock oscillator is connected to the FPGA fabric M1 and N1 pins.

The following table provides package and pin details of the 100 MHz oscillator.

Table 9 • 100 MHz Clock

SmartFusion2 Advanced Development Kit Pin Name	SmartFusion2 Package Pin Number	SmartFusion2 Device Pin Name
100MHZ_DIFFCLK_P	N1	MSIO40PB4/CCC_NE1_CLKI1
100MHZ_DIFFCLK_N	M1	MSIO40NB4

The following figure shows the 100 MHz clock oscillator interface.

Figure 16 • 100 MHz Clock Oscillator Interface

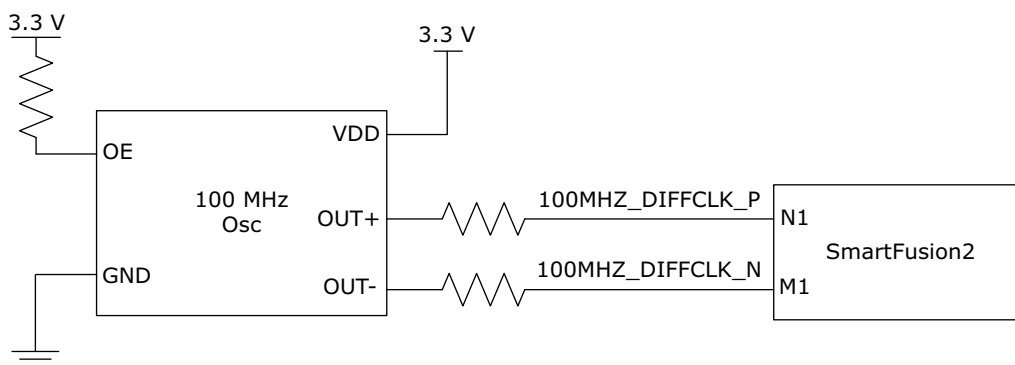

For more information, see the Board Level Schematics document (provided separately).

4.11 User Interface

The SmartFusion2 Advanced Development Board UI has user LEDs as well as push-button switches.

4.11.1 User LEDs

The board has eight active-low LEDs connected to the SmartFusion2 device that can be used to debug applications. The following table lists the on-board user LEDs.

Table 10 • LEDs

SmartFusion2 Advanced Development Board Pin	SmartFusion2 Package Pin Number	SmartFusion2 Device Pin Name
DS0	D26	DDRIO149PB1/FDDR_DQS2
DS1	F26	DDRIO150PB1/FDDR_DQ18
DS2	A27	DDRIO148PB1/FDDR_DM_RD QS2
DS3	C26	DDRIO149NB1/FDDR_DQS2_N
DS4	C28	DDRIO151PB1/FDDR_DQ16
DS5	B27	DDRIO148NB1/FDDR_DQ20
DS6	C27	DDRIO151NB1/FDDR_DQ17
DS7	E26	DDRIO150NB1/FDDR_DQ19

The following figure shows the LED interface of the SmartFusion2 Advanced Development Board.

Figure 17 • LED Interface

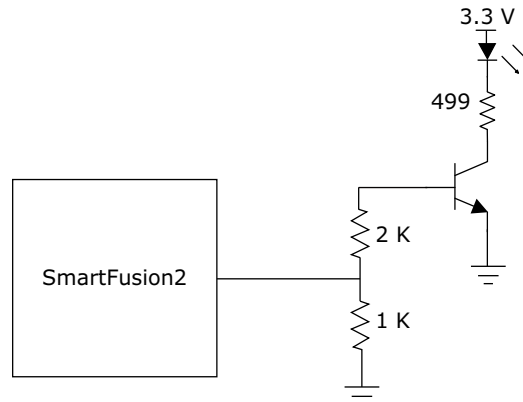

For more information, see the Board Level Schematics document (provided separately).

4.11.2 Push-Button Switches

The SmartFusion2 Advanced Development Kit comes with five push-button tactile switches that are connected to the SmartFusion2 device. The following table lists the on-board push-button switches.

Table 11 • Push-Button Switches

SmartFusion2 Advanced Development Board Pin	SmartFusion2 Package Pin Number	SmartFusion2 Device Pin Name
SWITCH1	J25	DDRIO156PB1/FDDR_DQ10
SWITCH2	H25	DDRIO156NB1/FDDR_DQ11
SWITCH3	J24	DDRIO157PB1/FDDR_DQ8
SWITCH4	H23	DDRIO157NB1/FDDR_DQ9
SW6	AE5	System Reset

The following figure shows the switches interface of the SmartFusion2 Advanced Development Board.

Figure 18 • Switches Interface

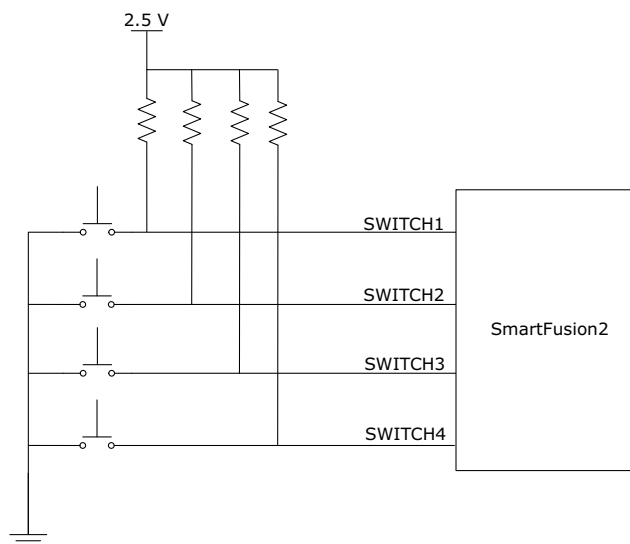

For more information, see the Board Level Schematics document (provided separately).

4.11.3 Slide Switches - DPDT

The **SW7** switch powers the device ON or OFF switch from the +12 V external DC jack (J42).

4.11.4 DIP Switch - SPST

The **SW5** DIP switch has eight connections to the SmartFusion2 device.

The following table lists the on-board DIP switches.

Table 12 • DIP Switches

SmartFusion2 Advanced Development Board Pin	SmartFusion2 Package Pin Number	SmartFusion2 Device Pin Name
DIP0	F25	DDRIO152PB1/FDDR_DQ14
DIP1	G25	DDRIO152NB1/FDDR_DQ15
DIP2	J23	DDRIO153PB1/FDDR_DQ12
DIP3	J22	DDRIO153NB1/FDDR_DQ13
DIP4	G27	DDRIO154PB1/FDDR_TMATCH_0_IN
DIP5	H27	DDRIO154NB1/FDDR_DM_RDQS1
DIP6	F23	DDRIO155PB1/FDDR_QS1
DIP7	G23	DDRIO155NB1/FDDR_QS1_N

The following figure shows the SPST interface of the SmartFusion2 Advanced Development Board.

Figure 19 • SPST Interface

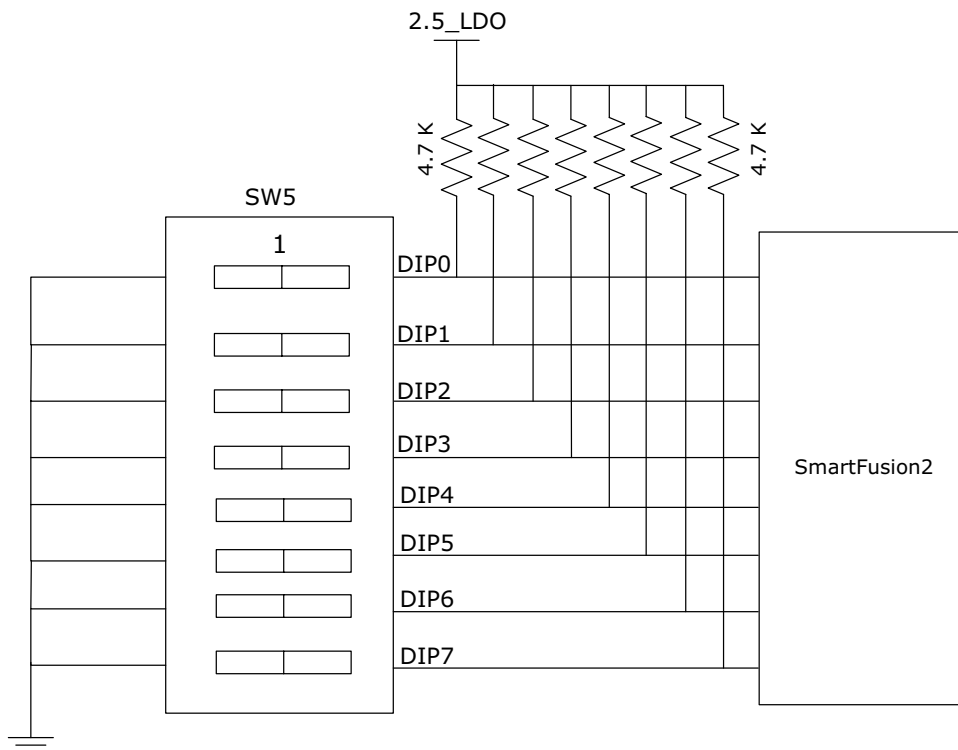

For more information, see the Board Level Schematics document (provided separately).

4.11.5 FMC Connectors

SmartFusion2 Advanced Development Kit has HPC (J30) and LPC (J60) FMC connectors on the board for connecting the daughter cards to enable future expansion of interfaces.

4.11.5.1 FMC HPC Connector (J30)

The SmartFusion2 MSIOs from banks 0, 3, 5, 6, 8, 11, 14, 17, and 18, and the SERDES1 and SERDES2 signals are routed to the FMC connector for the application to be developed.

If the FMC daughter board is designed according to VITA standards, Bank0 and Bank5 I/Os draw power from the FMC daughter board. If it is not designed according to VITA standards, these I/Os can be powered from the on-board U37 regulator, by mounting an R1216 resistor.

The following table provides the FMC HPC header pinout details.

Table 13 • FMC HPC Connector (J30) Pinout

FMC Pin Number-J30	FMC Net Name	SmartFusion2 Pin Number	SmartFusion2 Pin name
A1	GND		
A2	FMC_HPC_SERDES2_RXD2_P	AM13	SERDES_2_RXD2_P
A3	FMC_HPC_SERDES2_RXD2_N	AL13	SERDES_2_RXD2_N
A4	GND		
A5	GND		
A6	FMC_HPC_SERDES2_RXD1_P	AM15	SERDES_2_RXD1_P
A7	FMC_HPC_SERDES2_RXD1_N	AL15	SERDES_2_RXD1_N
A8	GND		
A9	GND		
A10	FMC_HPC_SERDES2_RXD0_P	AM17	SERDES_2_RXD0_P
A11	FMC_HPC_SERDES2_RXD0_N	AL17	SERDES_2_RXD0_N
A12	GND		
A13	GND		
A14	FMC_HPC_SERDES1_RXD3_P	AL19	SERDES_1_RXD3_P
A15	FMC_HPC_SERDES1_RXD3_N	AM19	SERDES_1_RXD3_N
A16	GND		
A17	GND		
A18	FMC_HPC_SERDES1_RXD2_P	AL21	SERDES_1_RXD2_P
A19	FMC_HPC_SERDES1_RXD2_N	AM21	SERDES_1_RXD2_N
A20	GND		
A21	GND		
A22	FMC_HPC_SERDES2_TXD2_P	AN12	SERDES_2_TXD2_P
A23	FMC_HPC_SERDES2_TXD2_N	AP12	SERDES_2_TXD2_N
A24	GND		
A25	GND		
A26	FMC_HPC_SERDES2_TXD1_P	AN14	SERDES_2_TXD1_P
A27	FMC_HPC_SERDES2_TXD1_N	AP14	SERDES_2_TXD1_N

Table 13 • FMC HPC Connector (J30) Pinout (continued)

A28	GND		
A29	GND		
A30	FMC_HPC_SERDES2_TXD0_P	AN16	SERDES_2_TXD0_P
A31	FMC_HPC_SERDES2_TXD0_N	AP16	SERDES_2_TXD0_N
A32	GND		
A33	GND		
A34	FMC_HPC_SERDES1_TXD3_P	AP18	SERDES_1_TXD3_P
A35	FMC_HPC_SERDES1_TXD3_N	AN18	SERDES_1_TXD3_N
A36	GND		
A37	GND		
A38	FMC_HPC_SERDES1_TXD2_P	AP20	SERDES_1_TXD2_P
A39	FMC_HPC_SERDES1_TXD2_N	AN20	SERDES_1_TXD2_N
A40	GND		
B1	NC		
B2	GND		
B3	GND		
B4	NC		
B5	NC		
B6	GND		
B7	GND		
B8	NC		
B9	NC		
B10	GND		
B11	GND		
B12	FMC_HPC_SERDES1_RXD0_P	AL25	SERDES_1_RXD0_P
B13	FMC_HPC_SERDES1_RXD0_N	AM25	SERDES_1_RXD0_N
B14	GND		
B15	GND		
B16	FMC_HPC_SERDES1_RXD1_P	AL23	SERDES_1_RXD1_P
B17	FMC_HPC_SERDES1_RXD1_N	AM23	SERDES_1_RXD1_N
B18	GND		
B19	GND		
B20	FMC_HPC_SERDES1_REFCLK0_P	AJ22	MSIOD271PB12/SERDES_1_REFCLK0_P
B21	FMC_HPC_SERDES1_REFCLK0_N	AK22	MSIOD271NB12/SERDES_1_REFCLK0_N
B22	GND		
B23	GND		
B24	NC		
B25	NC		
B26	GND		

Table 13 • FMC HPC Connector (J30) Pinout (continued)

B27	GND		
B28	NC		
B29	NC		
B30	GND		
B31	GND		
B32	FMC_HPC_SERDES1_TXD0_P	AP24	SERDES_1_TXD0_P
B33	FMC_HPC_SERDES1_TXD0_N	AN24	SERDES_1_TXD0_N
B34	GND		
B35	GND		
B36	FMC_HPC_SERDES1_TXD1_P	AP22	SERDES_1_TXD1_P
B37	FMC_HPC_SERDES1_TXD1_N	AN22	SERDES_1_TXD1_N
B38	GND		
B39	GND		
B40	NC		
C1	GND		
C2	FMC_HPC_SERDES2_TXD3_P	AN10	SERDES_2_TXD3_P
C3	FMC_HPC_SERDES2_TXD3_N	AP10	SERDES_2_TXD3_N
C4	GND		
C5	GND		
C6	FMC_HPC_SERDES2_RXD3_P	AM11	SERDES_2_RXD3_P
C7	FMC_HPC_SERDES2_RXD3_N	AL11	SERDES_2_RXD3_N
C8	GND		
C9	GND		
C10	HPC_LA06_M32_191P_B18	M32	MSIO191PB18
C11	HPC_LA06_M31_191N_B18	M31	MSIO191NB18
C12	GND		
C13	GND		
C14	HPC_LA10_T23_206P_B17	T23	MSIO206PB17
C15	HPC_LA10_T24_206N_B17	T24	MSIO206NB17
C16	GND		
C17	GND		
C18	HPC_LA14_P29_198P_B17	P29	MSIO198PB17
C19	HPC_LA14_P28_198N_B17	P28	MSIO198NB17
C20	GND		
C21	GND		
C22	HPC_LA18_CC_U29_215P_B17	U29	MSIO215PB17/CCC_NW1_CLKI0
C23	HPC_LA18_CC_U30_215N_B17	U30	MSIO215NB17
C24	GND		
C25	GND		

Table 13 • FMC HPC Connector (J30) Pinout (continued)

C26	HPC_LA27_P34_208P_B17	P34	MSIO208PB17
C27	HPC_LA27_N34_208N_B17	N34	MSIO208NB17
C28	GND		
C29	GND		
C30	I2C0_SCL	K10	MSIO81NB3/I2C_0_SCL/GPIO_31_B/USB_DATA1_C
C31	I2C0_SDA	K9	MSIO81PB3/I2C_0_SDA/GPIO_30_B/USB_DATA0_C
C32	GND		
C33	GND		
C34	GND		
C35	12P0V		
C36	GND		
C37	12P0V		
C38	GND		
C39	3P3V		
C40	GND		
D1	HPC_PG_C2M_H6_77N_B3	H6	MSIO77NB3/MMUART_0_DSR/GPIO_20_B
D2	GND		
D3	GND		
D4	FMC_HPC_SERDES2_REFCLK0_P	AK14	MSIOD277PB10/SERDES_2_REFCLK0_P
D5	FMC_HPC_SERDES2_REFCLK0_N	AJ14	MSIOD277NB10/SERDES_2_REFCLK0_N
D6	GND		
D7	GND		
D8	HPC_LA01_CC_U27_216P_B17	U27	MSIO216PB17/CCC_NW0_CLKI0
D9	HPC_LA01_CC_U26_216N_B17	U26	MSIO216NB17
D10	GND		
D11	HPC_LA05_N23_186P_B18	N23	MSIO186PB18
D12	HPC_LA05_N24_186N_B18	N24	MSIO186NB18
D13	GND		
D14	HPC_LA09_R23_200P_B17	R23	MSIO200PB17
D15	HPC_LA09_R24_200N_B17	R24	MSIO200NB17
D16	GND		
D17	HPC_LA13_R26_202P_B17	R26	MSIO202PB17
D18	HPC_LA13_R25_202N_B17	R25	MSIO202NB17
D19	GND		
D20	HPC_LA17_CC_U31_213P_B17	U31	MSIO213PB17/GB6/CCC_NW1_CLKI1
D21	HPC_LA17_CC_U32_213N_B17	U32	MSIO213NB17
D22	GND		
D23	HPC_LA23_T33_212P_B17	T33	MSIO212PB17

Table 13 • FMC HPC Connector (J30) Pinout (continued)

D24	HPC_LA23_T32_212N_B17	T32	MSIO212NB17
D25	GND		
D26	HPC_LA26_L33_190P_B18	L33	MSIO190PB18
D27	HPC_LA26_L32_190N_B18	L32	MSIO190NB18
D28	GND		
D29	HPC_TCK		
D30	HPC_TDI		
D31	HPC_TDO		
D32	3P3V		
D33	HPC_TMS		
D34	HPC_TRST_L		
D35	GND		
D36	3P3V		
D37	GND		
D38	3P3V		
D39	GND		
D40	3P3V		
E1	GND		
E2	HPC_HA01_CC_AF16_276P_B11	AF16	MSIO276PB11/GB11/VCCC_SE0_CLKI
E3	HPC_HA01_CC_AG16_276N_B11	AG16	MSIO276NB11
E4	GND		
E5	GND		
E6	HPC_HA05_AA3_17P_B6	AA3	MSIO17PB6
E7	HPC_HA05_AA2_17N_B6	AA2	MSIO17NB6
E8	GND		
E9	HPC_HA09_AJ2_285P_B8	AJ2	MSIO285PB8
E10	HPC_HA09_AH3_285N_B8	AH3	MSIO285NB8
E11	GND		
E12	HPC_HA13_AH6_283P_B8	AH6	MSIO283PB8
E13	HPC_HA13_AH5_283N_B8	AH5	MSIO283NB8
E14	GND		
E15	HPC_HA16_AG7_284P_B8	AG7	MSIO284PB8
E16	HPC_HA16_AF7_284N_B8	AF7	MSIO284NB8
E17	GND		
E18	HPC_HA20_AB8_8P_B6	AB8	MSIO8PB6
E19	HPC_HA20_AB7_8N_B6	AB7	MSIO8NB6
E20	GND		
E21	HPC_HB03_W1_20P_B5	W1	MSIO20PB5
E22	HPC_HB03_W2_20N_B5	W2	MSIO20NB5

Table 13 • FMC HPC Connector (J30) Pinout (continued)

E23	GND		
E24	HPC_HB05_Y2_19P_B5	Y2	MSIO19PB5
E25	HPC_HB05_Y1_19N_B5	Y1	MSIO19NB5
E26	GND		
E27	HPC_HB09_V4_30P_B5	V4	MSIO30PB5/USB_DATA0_B
E28	HPC_HB09_V5_30N_B5	V5	MSIO30NB5/USB_DATA1_B
E29	GND		
E30	HPC_HB13_U2_29P_B5	U2	MSIO29PB5/USB_STP_B
E31	HPC_HB13_U3_29N_B5	U3	MSIO29NB5/USB_NXT_B
E32	GND		
E33	HPC_HB19_H31_175P_B0	H31	MSIO175PB0
E34	HPC_HB19_G31_175N_B0	G31	MSIO175NB0
E35	GND		
E36	HPC_HB21_L25_174P_B0	L25	MSIO174PB0
E37	HPC_HB21_L26_174N_B0	L26	MSIO174NB0
E38	GND		
E39	VCCIO_HPC_VADJ		
E40	GND		
F1	HPC_PG_M2C_J6_78P_B3	J6	MSIO78PB3/MMUART_0_RI/GPIO_21_B
F2	GND		
F3	GND		
F4	HPC_HA00_CC_AJ4_282P_B8	AJ4	MSIO282PB8/VCCC_SE1_CLKI
F5	HPC_HA00_CC_AJ3_282N_B8	AJ3	MSIO282NB8
F6	GND		
F7	HPC_HA04_AG3_287P_B8	AG3	MSIO287PB8
F8	HPC_HA04_AG4_287N_B8	AG4	MSIO287NB8
F9	GND		
F10	HPC_HA08_AD1_9P_B6	AD1	MSIO9PB6
F11	HPC_HA08_AC1_9N_B6	AC1	MSIO9NB6
F12	GND		
F13	HPC_HA12_AE4_4P_B6	AE4	MSIO4PB6
F14	HPC_HA12_AD4_4N_B6	AD4	MSIO4NB6
F15	GND		
F16	HPC_HA15_AA7_15P_B6	AA7	MSIO15PB6
F17	HPC_HA15_Y7_15N_B6	Y7	MSIO15NB6
F18	GND		
F19	HPC_HA19_AB10_11P_B6	AB10	MSIO11PB6
F20	HPC_HA19_AA10_11N_B6	AA10	MSIO11NB6
F21	GND		

Table 13 • FMC HPC Connector (J30) Pinout (continued)

F22	HPC_HB02_V1_26P_B5	V1	MSIO26PB5/GPIO_27_A
F23	HPC_HB02_U1_26N_B5	U1	MSIO26NB5/GPIO_28_A
F24	GND		
F25	HPC_HB04_W3_25P_B5	W3	MSIO25PB5
F26	HPC_HB04_V3_25N_B5	V3	MSIO25NB5
F27	GND		
F28	HPC_HB08_Y6_18P_B5	Y6	MSIO18PB5
F29	HPC_HB08_Y5_18N_B5	Y5	MSIO18NB5
F30	GND		
F31	HPC_HB12_W8_27P_B5	W8	MSIO27PB5
F32	HPC_HB12_W9_27N_B5	W9	MSIO27NB5/USB_DATA7_B
F33	GND		
F34	HPC_HB16_Y12_21P_B5	Y12	MSIO21PB5
F35	HPC_HB16_Y11_21N_B5	Y11	MSIO21NB5
F36	GND		
F37	HPC_HB20_W12_28P_B5	W12	MSIO28PB5/USB_XCLK_B
F38	HPC_HB20_W11_28N_B5	W11	MSIO28NB5/USB_DIR_B
F39	GND		
F40	VCCIO_HPC_VADJ		
G1	GND		
G2	HPC_CLK1_M2C_AH28_267P_B14	AH28	MSIO267PB14/CCC_SW0_CLKI2
G3	HPC_CLK1_M2C_AG27_267N_B14	AG27	MSIO267NB14
G4	GND		
G5	GND		
G6	HPC_LA00_CC_U23_214P_B17	U23	MSIO214PB17/GB2/CCC_NW0_CLKI1
G7	HPC_LA00_CC_U24_214N_B17	U24	MSIO214NB17
G8	GND		
G9	HPC_LA03_N32_201P_B17	N32	MSIO201PB17
G10	HPC_LA03_N31_201N_B17	N31	MSIO201NB17
G11	GND		
G12	HPC_LA08_M25_181P_B18	M25	MSIO181PB18
G13	HPC_LA08_M24_181N_B18	M24	MSIO181NB18
G14	GND		
G15	HPC_LA12_M27_183P_B18	M27	MSIO183PB18
G16	HPC_LA12_M26_183N_B18	M26	MSIO183NB18
G17	GND		
G18	HPC_LA16_T28_209P_B17	T28	MSIO209PB17
G19	HPC_LA16_T27_209N_B17	T27	MSIO209NB17
G20	GND		

Table 13 • FMC HPC Connector (J30) Pinout (continued)

G21	HPC_LA20_R31_205P_B17	R31	MSIO205PB17
G22	HPC_LA20_R30_205N_B17	R30	MSIO205NB17
G23	GND		
G24	HPC_LA22_R33_207P_B17	R33	MSIO207PB17
G25	HPC_LA22_R32_207N_B17	R32	MSIO207NB17
G26	GND		
G27	HPC_LA25_M34_197P_B17	M34	MSIO197PB17
G28	HPC_LA25_L34_197N_B17	L34	MSIO197NB17
G29	GND		
G30	HPC_LA29_J34_194P_B18	J34	MSIO194PB18
G31	HPC_LA29_J33_194N_B18	J33	MSIO194NB18
G32	GND		
G33	HPC_LA31_H34_196P_B18	H34	MSIO196PB18
G34	HPC_LA31_G34_196N_B18	G34	MSIO196NB18
G35	GND		
G36	HPC_LA33_E33_176P_B18	E33	MSIO176PB18
G37	HPC_LA33_D33_176N_B18	D33	MSIO176NB18
G38	GND		
G39	VCCIO_HPC_VADJ		
G40	GND		
H1	N36608719		
H2	HPC_PRSNT_M2CL_J7_78N_B3	J7	MSIO78NB3/MMUART_0_DCD/GPIO_22_B
H3	GND		
H4	HPC_CLK0_M2C_AJ6_281P_B8	AJ6	MSIO281PB8/GB15/VCCC_SE1_CLKI
H5	HPC_CLK0_M2C_AJ5_281N_B8	AJ5	MSIO281NB8
H6	GND		
H7	HPC_LA02_K31_179P_B18	K31	MSIO179PB18
H8	HPC_LA02_K30_179N_B18	K30	MSIO179NB18
H9	GND		
H10	HPC_LA04_L30_182P_B18	L30	MSIO182PB18
H11	HPC_LA04_L29_182N_B18	L29	MSIO182NB18
H12	GND		
H13	HPC_LA07_P23_192P_B18	P23	MSIO192PB18
H14	HPC_LA07_P24_192N_B18	P24	MSIO192NB18
H15	GND		
H16	HPC_LA11_T30_210P_B17	T30	MSIO210PB17
H17	HPC_LA11_T29_210N_B17	T29	MSIO210NB17
H18	GND		
H19	HPC_LA15_M30_188P_B18	M30	MSIO188PB18

Table 13 • FMC HPC Connector (J30) Pinout (continued)

H20	HPC_LA15_M29_188N_B18	M29	MSIO188NB18
H21	GND		
H22	HPC_LA19_P31_199P_B17	P31	MSIO199PB17
H23	HPC_LA19_P30_199N_B17	P30	MSIO199NB17
H24	GND		
H25	HPC_LA21_P33_203P_B17	P33	MSIO203PB17
H26	HPC_LA21_N33_203N_B17	N33	MSIO203NB17
H27	GND		
H28	HPC_LA24_K33_187P_B18	K33	MSIO187PB18
H29	HPC_LA24_K32_187N_B18	K32	MSIO187NB18
H30	GND		
H31	HPC_LA28_H33_184P_B18	H33	MSIO184PB18
H32	HPC_LA28_H32_184N_B18	H32	MSIO184NB18
H33	GND		
H34	HPC_LA30_F34_185P_B18	F34	MSIO185PB18
H35	HPC_LA30_F33_185N_B18	F33	MSIO185NB18
H36	GND		
H37	HPC_LA32_D34_180P_B18	D34	MSIO180PB18
H38	HPC_LA32_C34_180N_B18	C34	MSIO180NB18
H39	GND		
H40	VCCIO_HPC_VADJ		
J1	GND		
J2	HPC_CLK3_M2C_P	AK12	MSIOD278PB10/SERDES_2_REFCLK1_P
J2	HPC_CLK3_M2C_P	AE17	MSIO275PB11/VCCC_SE0_CLKI
J3	HPC_CLK3_M2C_N	AJ12	MSIOD278NB10/SERDES_2_REFCLK1_N
J3	HPC_CLK3_M2C_N	AF17	MSIO275NB11
J4	GND		
J5	GND		
J6	HPC_HA03_AA4_12P_B6	AA4	MSIO12PB6
J7	HPC_HA03_AA5_12N_B6	AA5	MSIO12NB6
J8	GND		
J9	HPC_HA07_AC3_10P_B6	AC3	MSIO10PB6
J10	HPC_HA07_AB3_10N_B6	AB3	MSIO10NB6
J11	GND		
J12	HPC_HA11_AD3_5P_B6	AD3	MSIO5PB6
J13	HPC_HA11_AD2_5N_B6	AD2	MSIO5NB6
J14	GND		
J15	HPC_HA14_AG6_286P_B8	AG6	MSIO286PB8
J16	HPC_HA14_AG5_286N_B8	AG5	MSIO286NB8

Table 13 • FMC HPC Connector (J30) Pinout (continued)

J17	GND		
J18	HPC_HA18_AC9_3P_B6	AC9	MSIO3PB6
J19	HPC_HA18_AC8_3N_B6	AC8	MSIO3NB6
J20	GND		
J21	HPC_HA22_AA8_13P_B6	AA8	MSIO13PB6
J22	HPC_HA22_AA9_13N_B6	AA9	MSIO13NB6
J23	GND		
J24	HPC_HB01_R1_32P_B5	R1	MSIO32PB5/USB_DATA4_B
J25	HPC_HB01_R2_32N_B5	R2	MSIO32NB5/USB_DATA5_B
J26	GND		
J27	HPC_HB07_Y4_24P_B5	Y4	MSIO24PB5
J28	HPC_HB07_W4_24N_B5	W4	MSIO24NB5
J29	GND		
J30	HPC_HB11_W6_23P_B5	W6	MSIO23PB5
J31	HPC_HB11_W7_23N_B5	W7	MSIO23NB5
J32	GND		
J33	HPC_HB15_V9_34P_B5	V9	MSIO34PB5
J34	HPC_HB15_V10_34N_B5	V10	MSIO34NB5
J35	GND		
J36	HPC_HB18_T2_31P_B5	T2	MSIO31PB5/USB_DATA2_B
J37	HPC_HB18_T3_31N_B5	T3	MSIO31NB5/USB_DATA3_B
J38	GND		
J39	VCCIO_HPC_VIO_B_M2C_FMC		
J40	GND		
K1	N36626276		
K2	GND		
K3	GND		
K4	HPC_CLK2_M2C_P	AJ20	MSIOD272PB12/SERDES_1_REFCLK1_P
K4	HPC_CLK2_M2C_P	AF18	MSIO274PB11/CCC_SW1_CLKI2
K5	HPC_CLK2_M2C_N	AK20	MSIOD272NB12/SERDES_1_REFCLK1_N
K5	HPC_CLK2_M2C_N	AG18	MSIO274NB11/CCC_SW1_CLKI3
K6	GND		
K7	HPC_HA02_AB2_16P_B6	AB2	MSIO16PB6
K8	HPC_HA02_AB1_16N_B6	AB1	MSIO16NB6
K9	GND		
K10	HPC_HA06_AC5_6P_B6	AC5	MSIO6PB6
K11	HPC_HA06_AC4_6N_B6	AC4	MSIO6NB6
K12	GND		
K13	HPC_HA10_AE6_288P_B8	AE6	MSIO288PB8

Table 13 • FMC HPC Connector (J30) Pinout (continued)

K14	HPC_HA10_AF5_288N_B8	AF5	MSIO288NB8
K15	GND		
K16	HPC_HA17_CC_AJ29_268P_B14	AJ29	MSIO268PB14/GB3/CCC_SW0_CLKI3
K17	HPC_HA17_CC_AJ28_268N_B14	AJ28	MSIO268NB14
K18	GND		
K19	HPC_HA21_AA12_14P_B6	AA12	MSIO14PB6
K20	HPC_HA21_AA11_14N_B6	AA11	MSIO14NB6
K21	GND		
K22	HPC_HA23_AB5_7P_B6	AB5	MSIO7PB6
K23	HPC_HA23_AB6_7N_B6	AB6	MSIO7NB6
K24	GND		
K25	HPC_HB00_CC_F32_172P_B0	F32	MSIO172PB0/GB0/CCC_NW0_CLKI3
K26	HPC_HB00_CC_E32_172N_B0	E32	MSIO172NB0
K27	GND		
K28	HPC_HB06_CC_J29_170P_B0	J29	MSIO170PB0/CCC_NW1_CLKI3
K29	HPC_HB06_CC_J28_170N_B0	J28	MSIO170NB0
K30	GND		
K31	HPC_HB10_Y10_22P_B5	Y10	MSIO22PB5
K32	HPC_HB10_Y9_22N_B5	Y9	MSIO22NB5
K33	GND		
K34	HPC_HB14_V6_33P_B5	V6	MSIO33PB5/USB_DATA6_B
K35	HPC_HB14_U6_33N_B5	U6	MSIO33NB5
K36	GND		
K37	HPC_HB17_CC_U5_37P_B5	U5	MSIO37PB5/GB9/VCCC_SE0_CLKI
K38	HPC_HB17_CC_T5_37N_B5	T5	MSIO37NB5
K39	GND		
K40	VCCIO_HPC_VIO_B_M2C_FMC		

4.11.5.2 FMC LPC Connector (J60)

The SmartFusion2 MSIODs from banks 15 and 16 and the SERFDES3 lane 0 signals are routed to the FMC connector for the application to be developed.

The following table provides the FMC LPC header pinout details.

Table 14 • FMC LPC Connector (J60) Pinout

FMC Pin Number - J60	FMC Net Name	SmartFusion2 Pin Number	SmartFusion2 Pin Name
C1	GND		
C2	FMC_LPC_SERDES3_TXD0_P	AN8	SERDES_3_TXD0_P
C3	FMC_LPC_SERDES3_TXD0_N	AP8	SERDES_3_TXD0_N
C4	GND		
C5	GND		
C6	FMC_LPC_SERDES3_RXD0_P	AM9	SERDES_3_RXD0_P
C7	FMC_LPC_SERDES3_RXD0_N	AL9	SERDES_3_RXD0_N
C8	GND		
C9	GND		
C10	LPC_LA06_AF33_248P_B15	AF33	MSIOD248PB15
C11	LPC_LA06_AE33_248N_B15	AE33	MSIOD248NB15
C12	GND		
C13	GND		
C14	LPC_LA10_AE30_250P_B15	AE30	MSIOD250PB15
C15	LPC_LA10_AD30_250N_B15	AD30	MSIOD250NB15
C16	GND		
C17	GND		
C18	LPC_LA14_W23_227P_B16	W23	MSIOD227PB16
C19	LPC_LA14_W24_227N_B16	W24	MSIOD227NB16
C20	GND		
C21	GND		
C22	LPC_LA18_CC_AA32_228P_B16	AA32	MSIOD228PB16
C23	LPC_LA18_CC_Y32_228N_B16	Y32	MSIOD228NB16
C24	GND		
C25	GND		
C26	LPC_LA27_V29_223P_B16	V29	MSIOD223PB16
C27	LPC_LA27_V28_223N_B16	V28	MSIOD223NB16
C28	GND		
C29	GND		
C30	I2C1_SCL	T8	MSIO45NB4/I2C_1_SCL/GPIO_1_A/U SB_DATA4_A
C31	I2C1_SDA	T9	MSIO45PB4/I2C_1_SDA/GPIO_0_A/U SB_DATA3_A

Table 14 • FMC LPC Connector (J60) Pinout (continued)

C32	GND		
C33	GND		
C34	GND		
C35	12P0V		
C36	GND		
C37	12P0V		
C38	GND		
C39	3P3V		
C40	GND		
D1	LPC_PGC2M_N12_71P_B3	N12	MSIO71PB3/MMUART_1_RTS/GPIO_11_B
D2	GND		
D3	GND		
D4	FMC_LPC_SERDES3_REFCLK0_P	AJ10	MSIOD279PB9/SERDES_3_REFCLK0_P
D5	FMC_LPC_SERDES3_REFCLK0_N	AK10	MSIOD279NB9/SERDES_3_REFCLK0_N
D6	GND		
D7	GND		
D8	LPC_LA01_CC_W34_219P_B16	W34	MSIOD219PB16/CCC_SW1_CLKI0
D9	LPC_LA01_CC_V34_219N_B16	V34	MSIOD219NB16
D10	GND		
D11	LPC_LA05_W29_226P_B16	W29	MSIOD226PB16
D12	LPC_LA05_W30_226N_B16	W30	MSIOD226NB16
D13	GND		
D14	LPC_LA09_Y28_231P_B16	Y28	MSIOD231PB16
D15	LPC_LA09_W28_231N_B16	W28	MSIOD231NB16
D16	GND		
D17	LPC_LA13_AC24_258P_B15	AC24	MSIOD258PB15
D18	LPC_LA13_AC23_258N_B15	AC23	MSIOD258NB15
D19	GND		
D20	LPC_LA17_CC_V23_220P_B16	V23	MSIOD220PB16/CCC_SW0_CLKI0
D21	LPC_LA17_CC_V24_220N_B16	V24	MSIOD220NB16
D22	GND		
D23	LPC_LA23_AG32_252P_B15	AG32	MSIOD252PB15
D24	LPC_LA23_AF32_252N_B15	AF32	MSIOD252NB15
D25	GND		
D26	LPC_LA26_V27_222P_B16	V27	MSIOD222PB16
D27	LPC_LA26_V26_222N_B16	V26	MSIOD222NB16
D28	GND		

Table 14 • FMC LPC Connector (J60) Pinout (continued)

D29	LPC_TCK		
D30	LPC_TDI		
D31	LPC_TDO		
D32	3P3V		
D33	LPC_TMS		
D34	LPC_TRST_L		
D35	GND		
D36	3P3V		
D37	GND		
D38	3P3V		
D39	GND		
D40	3P3V		
G1	GND		
G2	LPC_CLK1_M2C_U34_217P_B16	U34	MSIOD217PB16/GB5/CCC_SW1_CLK I1
G3	LPC_CLK1_M2C_T34_217N_B16	T34	MSIOD217NB16
G4	GND		
G5	GND		
G6	LPC_LA00_CC_Y33_224P_B16	Y33	MSIOD224PB16
G7	LPC_LA00_CC_W33_224N_B16	W33	MSIOD224NB16
G8	GND		
G9	LPC_LA03_AC34_232P_B16	AC34	MSIOD232PB16
G10	LPC_LA03_AB34_232N_B16	AB34	MSIOD232NB16
G11	GND		
G12	LPC_LA08_AC32_233P_B16	AC32	MSIOD233PB16
G13	LPC_LA08_AC33_233N_B16	AC33	MSIOD233NB16
G14	GND		
G15	LPC_LA12_W26_229P_B16	W26	MSIOD229PB16
G16	LPC_LA12_W25_229N_B16	W25	MSIOD229NB16
G17	GND		
G18	LPC_LA16_Y23_234P_B16	Y23	MSIOD234PB16
G19	LPC_LA16_Y24_234N_B16	Y24	MSIOD234NB16
G20	GND		
G21	LPC_LA20_AF27_257P_B15	AF27	MSIOD257PB15
G22	LPC_LA20_AE27_257N_B15	AE27	MSIOD257NB15
G23	GND		
G24	LPC_LA22_AG34_244P_B15	AG34	MSIOD244PB15
G25	LPC_LA22_AF34_244N_B15	AF34	MSIOD244NB15
G26	GND		

Table 14 • FMC LPC Connector (J60) Pinout (continued)

G27	LPC_LA25_AH33_255P_B15	AH33	MSIOD255PB15
G28	LPC_LA25_AH34_255N_B15	AH34	MSIOD255NB15
G29	GND		
G30	LPC_LA29_AC27_245P_B15	AC27	MSIOD245PB15
G31	LPC_LA29_AB27_245N_B15	AB27	MSIOD245NB15
G32	GND		
G33	LPC_LA31_AB24_251P_B15	AB24	MSIOD251PB15
G34	LPC_LA31_AB23_251N_B15	AB23	MSIOD251NB15
G35	GND		
G36	LPC_LA33_AD24_261P_B15	AD24	MSIOD261PB15
G37	LPC_LA33_AD25_261N_B15	AD25	MSIOD261NB15
G38	GND		
G39	VCCIO_LPC_VADJ		
G40	GND		
H1	N36478604		
H2	LPC_PRSNTM2CL_N11_71N_B3	N11	MSIO71NB3/MMUART_1_DTR/GPIO_12_B
H3	GND		
H4	LPC_CLK0_M2C_V32_218P_B16	V32	MSIOD218PB16/GB1/CCC_SW0_CLK I1
H5	LPC_CLK0_M2C_V33_218N_B16	V33	MSIOD218NB16
H6	GND		
H7	LPC_LA02_AA33_225P_B16	AA33	MSIOD225PB16
H8	LPC_LA02_AA34_225N_B16	AA34	MSIOD225NB16
H9	GND		
H10	LPC_LA04_AD33_239P_B16	AD33	MSIOD239PB16
H11	LPC_LA04_AD34_239N_B16	AD34	MSIOD239NB16
H12	GND		
H13	LPC_LA07_AE31_247P_B15	AE31	MSIOD247PB15
H14	LPC_LA07_AE32_247N_B15	AE32	MSIOD247NB15
H15	GND		
H16	LPC_LA11_AF30_254P_B15	AF30	MSIOD254PB15
H17	LPC_LA11_AG31_254N_B15	AG31	MSIOD254NB15
H18	GND		
H19	LPC_LA15_AF28_256P_B15	AF28	MSIOD256PB15
H20	LPC_LA15_AE28_256N_B15	AE28	MSIOD256NB15
H21	GND		
H22	LPC_LA19_AG30_260P_B15	AG30	MSIOD260PB15
H23	LPC_LA19_AF29_260N_B15	AF29	MSIOD260NB15
H24	GND		

Table 14 • FMC LPC Connector (J60) Pinout (continued)

H25	LPC_LA21_W31_221P_B16	W31	MSIOD221PB16
H26	LPC_LA21_V31_221N_B16	V31	MSIOD221NB16
H27	GND		
H28	LPC_LA24_AD28_249P_B15	AD28	MSIOD249PB15
H29	LPC_LA24_AD29_249N_B15	AD29	MSIOD249NB15
H30	GND		
H31	LPC_LA28_AB25_246P_B15	AB25	MSIOD246PB15
H32	LPC_LA28_AB26_246N_B15	AB26	MSIOD246NB15
H33	GND		
H34	LPC_LA30_AC25_253P_B15	AC25	MSIOD253PB15
H35	LPC_LA30_AC26_253N_B15	AC26	MSIOD253NB15
H36	GND		
H37	LPC_LA32_AE26_259P_B15	AE26	MSIOD259PB15
H38	LPC_LA32_AD26_259N_B15	AD26	MSIOD259NB15
H39	GND		
H40	VCCIO_LPC_VADJ		

5 Pin List

The SmartFusion2 Advanced Development Kit uses an M2S150TS-1FCG1152 device. For a list of all package pins in this device, see [SmartFusion2 FC1152 Pinouts](#).

6 Board Components Placement

The following figure shows the placement of various components on the SmartFusion2 Advanced Development Kit silkscreen.

Figure 20 • Silkscreen Top View

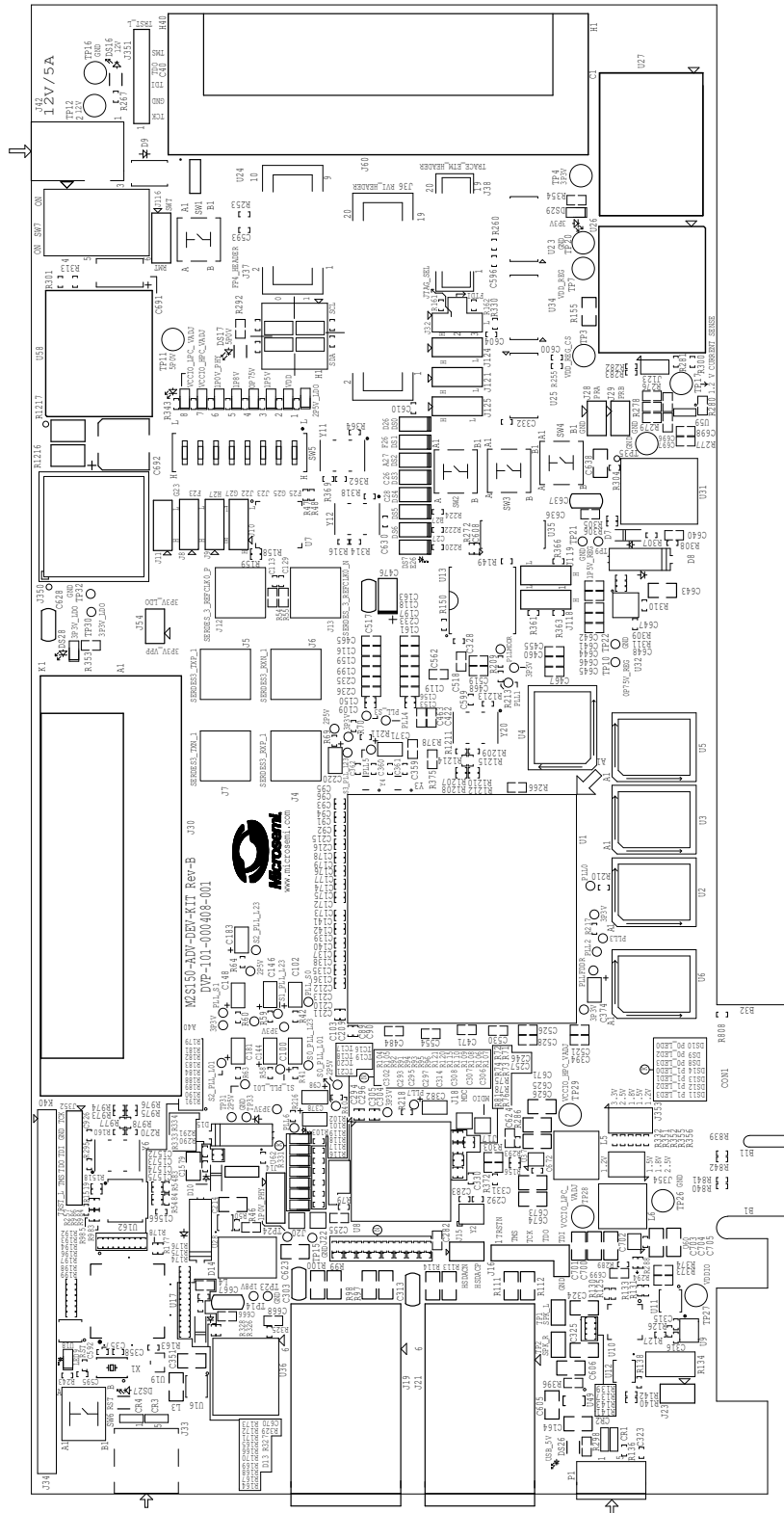

The following figure shows the bottom view of the SmartFusion2 Advanced Development Kit silkscreen.

Figure 21 • Silkscreen Bottom View

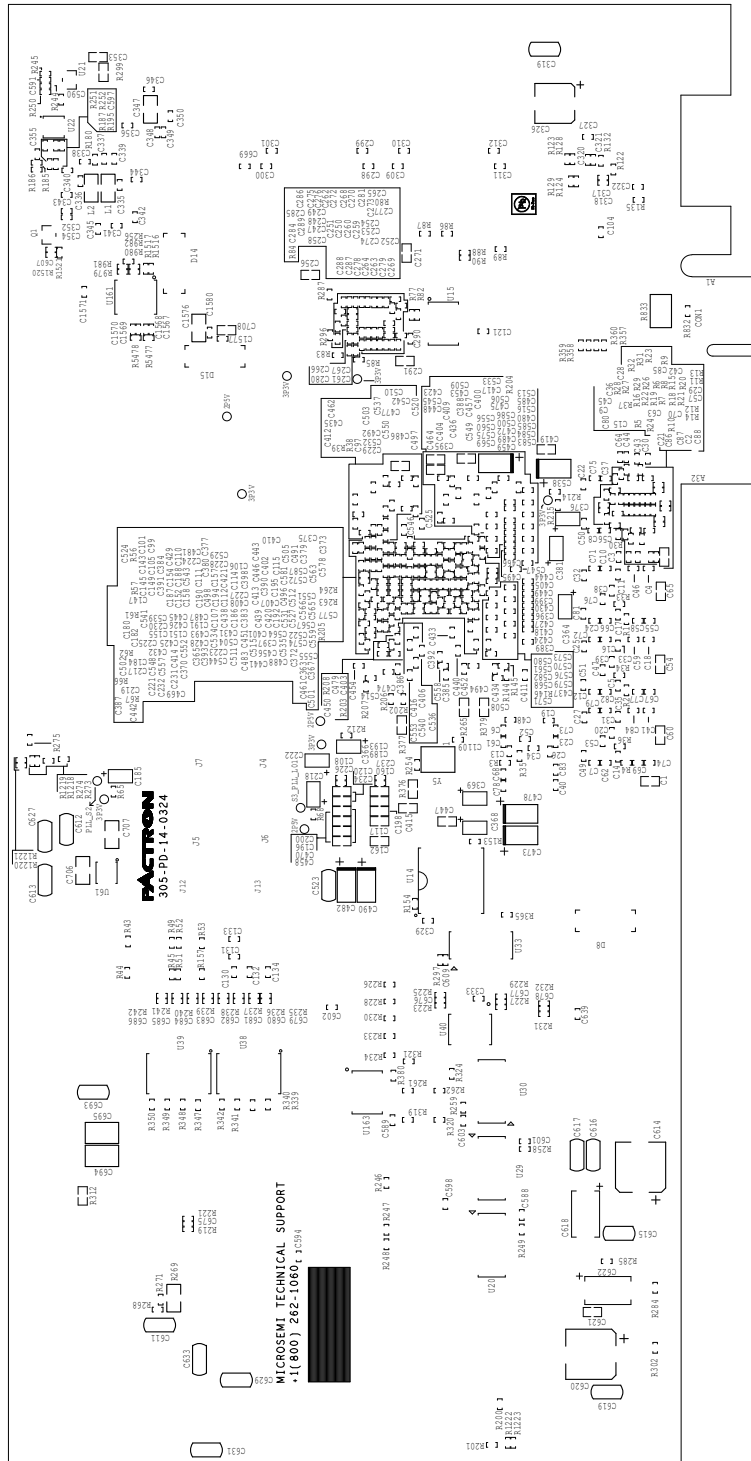

7 Demo Design

The SmartFusion2 M2S150-ADV-DEV-KIT comes with a preloaded PCIe control plane design. to demonstrate the PCIe interface of the SmartFusion2 device. The following figure shows the PCIe demo design window.

Figure 22 • PCIe Demo Design Window

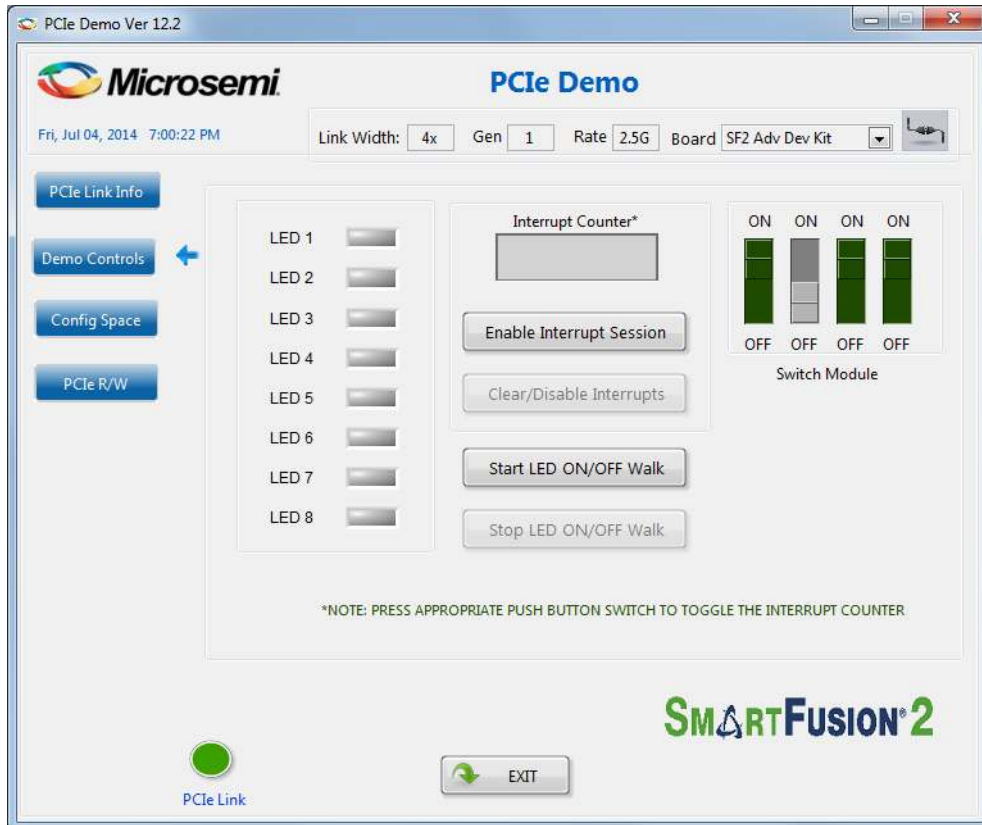

For more information about running the demo design, see *SmartFusion2 SoC FPGA PCIe Control Plane Demo Guide for Advanced Development Kit*.

8 Manufacturing Test

The M2S150-ADV-DEV-KIT device contains a manufacturing test program that can be run to verify the functionality of the board. This program contains a list of options that can be run as diagnostics. After Tera Term is set up and the board is powered up, various tests that can be performed on the board are displayed (see [Figure 29](#), page 51). One or more tests can then be selected from the list of available tests.

Before testing the SmartFusion2 Advanced Development Board:

- Download SEC_KIT_MTD_top.stp file from http://www.microsemi.com/document-portal/doc_download/134344-smartfusion2-advanced-development-kit-mtd.
- Download and install the FTD drivers from <http://www.ftdichip.com/Drivers/D2XX.htm>.

8.1 Programming M2S150-ADV-DEV-KIT

This section provides information about validating the power supply and programming the M2S150-ADV-DEV-KIT for the manufacturing test.

8.1.1 Validating Power Supply

To test and validate the power supply to the board:

1. Connect the following jumpers on the SmartFusion2 Advanced Development Board.
 - Short the **J116** jumper to position 1-2.
 - Short the **J123** jumper to position 2-3.
 - Short the **J353** jumper to position 1-2.
 - Short the **J354** jumper to position 1-2.
 - Short the **J54** jumper to position 1-2.

Note: Before making the jumper connections, switch OFF the **SW7** power supply switch.

2. Connect the 12 V/5 A power supply brick to the **J42** jumper.
3. Switch ON the **SW7** power supply switch.

8.1.2 Programming the FPGA Using Embedded FlashPro5

The M2S150-ADV-DEV-KIT has an embedded FlashPro5 programmer; therefore, an external programmer is not required to program the SmartFusion2 device. The device can be programmed using the embedded FlashPro5, provided the FlashPro software is installed on the host PC.

Note: The board can also be programmed using FlashPro4. To program the board using FlashPro4, connect the FlashPro4 header to the **J37** connector, and change the position of the **J124** jumper to pin 2-3.

To program the device using embedded FlashPro5:

1. Connect the following jumpers on the SmartFusion2 Advanced Development Board:
 - Short the **J124** jumper to position 1-2.
 - Short the **J121** jumper to position 1-2.
 - Short the **J32** jumper to position 1-2.
2. Connect one end of the mini USB to Type A USB cable to the **J33** jumper, and other end to the USB port of the host PC.
3. Launch the FlashPro v11.4 software.

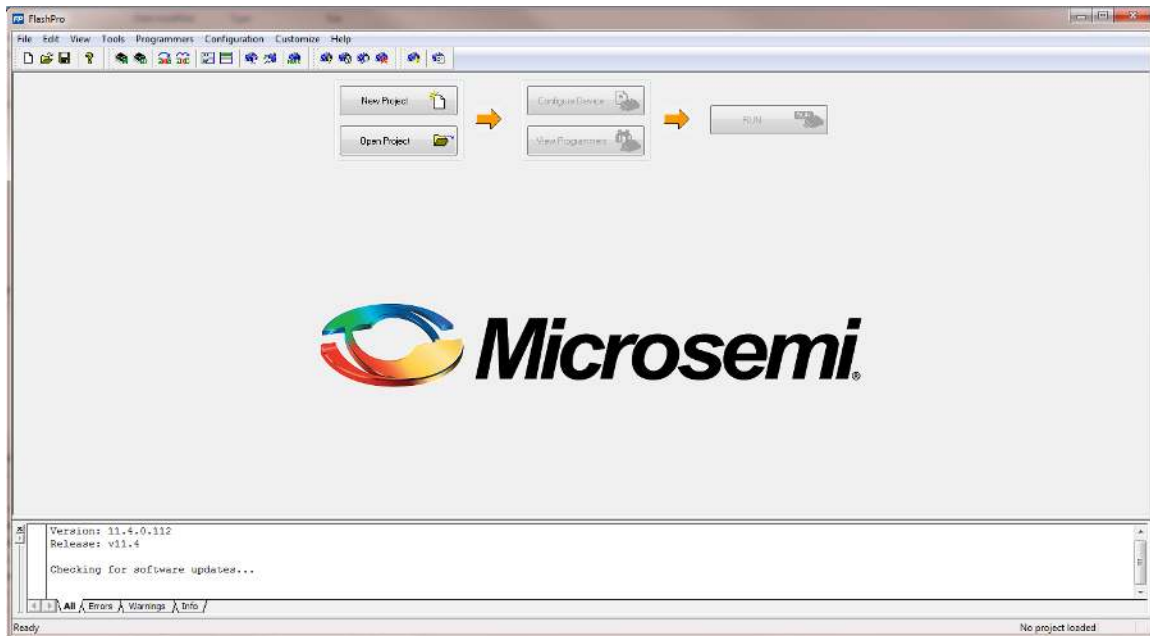
Figure 23 • FlashPro Window

4. Click **New Project** to create a new project.
5. In the **New Project** window, do the following, and click **OK**.
 - Enter a project name.
 - Select **Single device** as the programming mode.

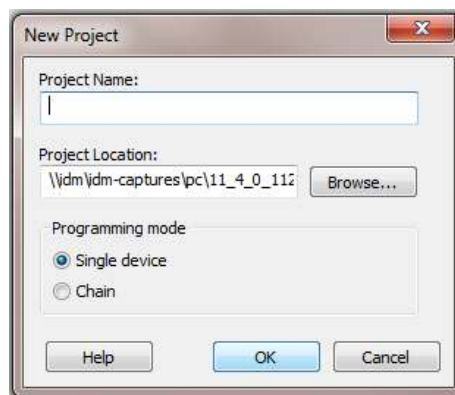
Figure 24 • New Project Window

6. Click **Configure Device**.

Figure 25 • Configuring the Device

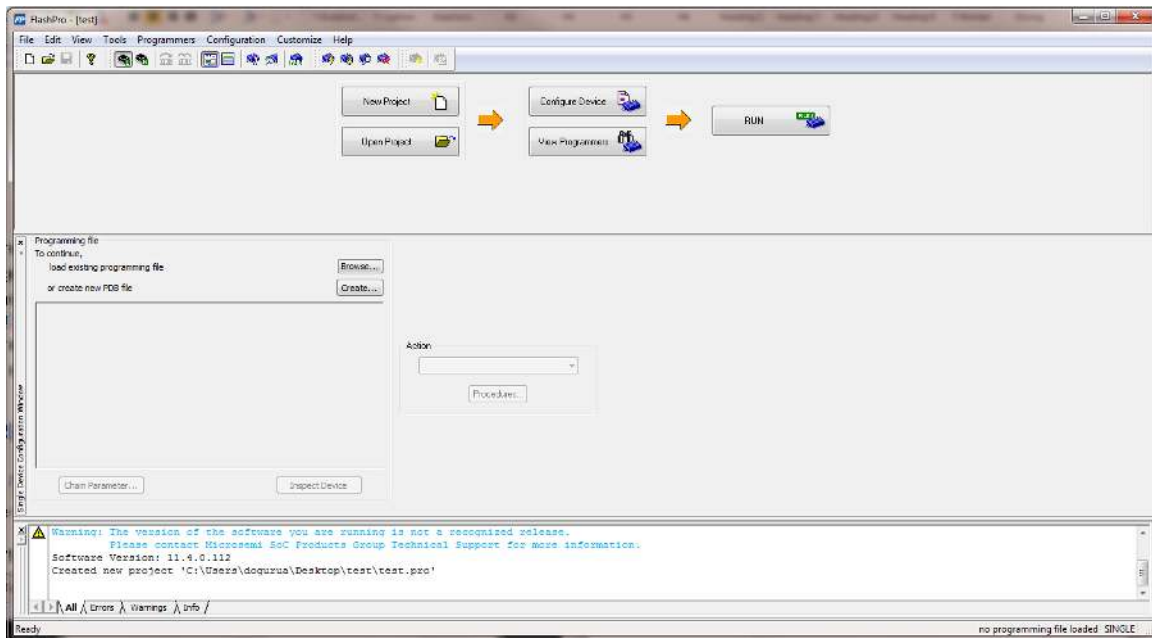

7. Click **Browse**, and select the `SEC_KIT_MTD_top.stp` file from the **Load Programming File** window.
8. Click **Program** to program the device.
9. Press the **SW4** switch.
The corresponding DS7 LED starts glowing, indicating that the device is programmed successfully.

8.2 Running the Manufacturing Test

This section describes how to run the manufacturing test for the SmartFusion2 Advanced Development Board.

8.2.1 Setting Up Tera Term

To set up Tera Term for the manufacturing test:

1. Connect one end of the mini USB to Type A USB cable to **J33**, and other end to the USB port of the host PC.
2. Launch **Tera Term** from the Start menu.

Figure 26 • Tera Term New Connection Window

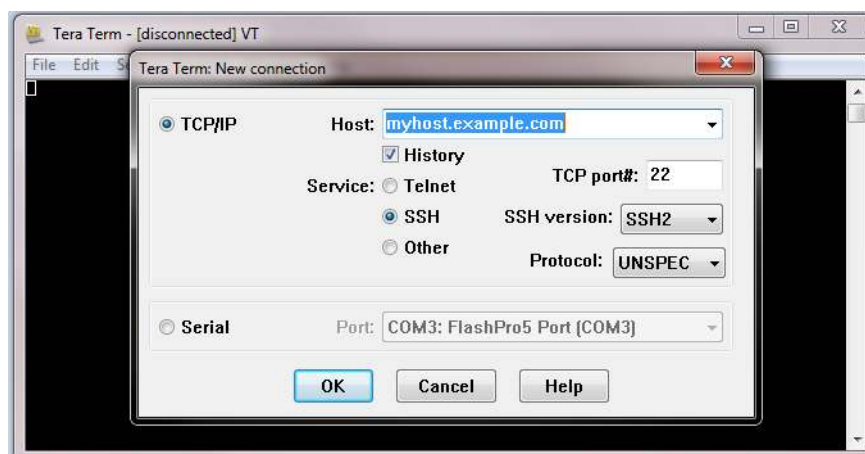

3. Select the **Serial** radio button.
4. Select a port from the **Port** drop-down list, and click **OK**.

Notes:

- When using a USB cable for Tera Term communication, four FlashPro5 COM ports are available in the **Port** drop-down list, as shown in the following figure. Select the third FlashPro5 COM port to establish the connection with the host PC.
- If FlashPro5 drivers are not installed properly, the drop-down list does not list FlashPro5 COM ports.

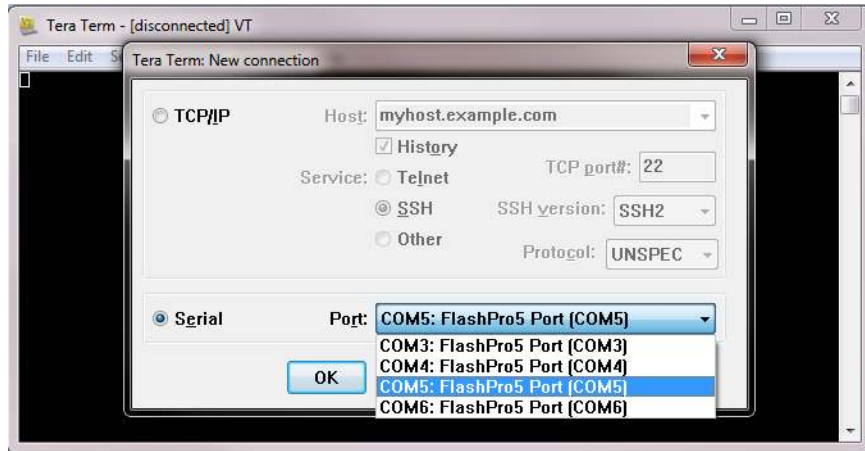
Figure 27 • Tera Term New Connection Window

5. On the **Tera Term Serial port setup** window, select the COM port to establish connection with the host PC, and enter the following Tera Term settings.
 - Baud rate = 57600
 - Data = 8 bit
 - Parity = none
 - Stop = 1 bit
 - Flow control = none

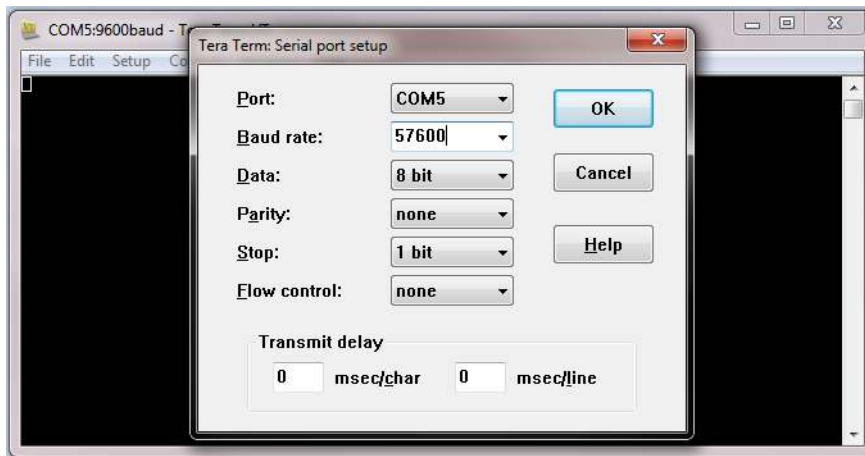
Figure 28 • Tera Term Serial Port Setup Window

6. Click **OK**.

8.2.2 Setting Up Jumpers

The following table specifies the jumper settings required to perform various tests on the SmartFusion2 Advanced Development Board.

Table 15 • Jumper Settings for Manufacturing Test

Interface	Jumper Settings
RTC test	
I2C test	On header (H1), short 10-6 and 11-7.
DDR3 memory test	
SPI0 memory test	Short J118 pin 1-2.
SPI1 memory test	Short J119 pin 1-2.
USB device test	Connect Micro B to P1, and connect the other end of the cable to the host PC (type A). This cable is required for testing on board USB device interface. Short J23 pin 1-2.
SGMII test	Connect an Ethernet cable to J19, and connect other end of the cable to the 1 Gbps Ethernet switch or network. Short J11 pin 1-2. Short J8 pin 1-2. Short J14 pin 1-2.
SerDes loopback test	Connect J4 to J5 and J6 to J7 using an SMA-to-SMA cable. Loopback cable (5 Gbps data rate). Short J11 pin 1-2. Short J8 pin 1-2.

8.2.3 Running the Test

After the device is programmed and the jumper settings are applied, follow these steps to run the manufacturing test.

1. Press the **SW6** reset switch on the M2S150-ADV-DEV-KIT board to reset the board and begin the tests.

When the setup is completed, all tests are listed in the HyperTerminal window, as shown in the following figure.

Figure 29 • Test Menu

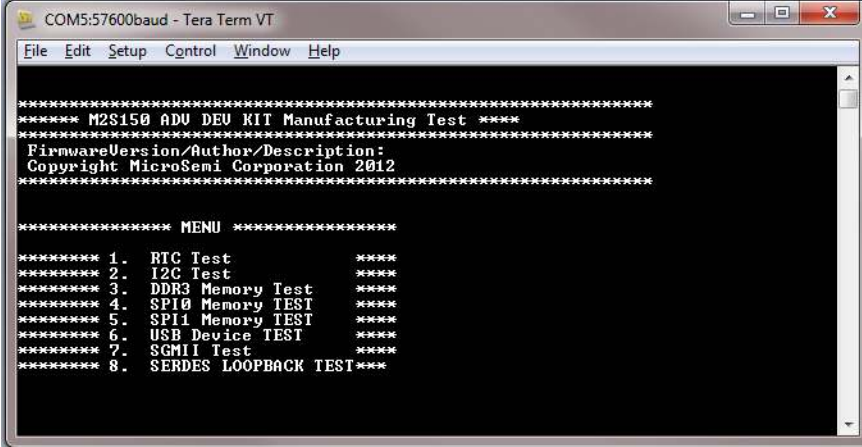

```

COM5:57600baud - Tera Term VT
File Edit Setup Control Window Help
***** M2S150 ADV DEV KIT Manufacturing Test ****
FirmwareVersion/Author/Description:
Copyright MicroSemi Corporation 2012
***** MENU *****
***** 1. RTC Test *****
***** 2. I2C Test *****
***** 3. DDR3 Memory Test *****
***** 4. SPI0 Memory TEST *****
***** 5. SPI1 Memory TEST *****
***** 6. USB Device TEST *****
***** 7. SGMII Test *****
***** 8. SERDES LOOPBACK TEST***

```

If the list of tests does not appear, press the **SW6** reset switch again. If the list still does not appear, then check all the jumpers and Tera Term settings.

2. Press **1** to run the RTC test.
The following message appears.

Figure 30 • Running RTC Test

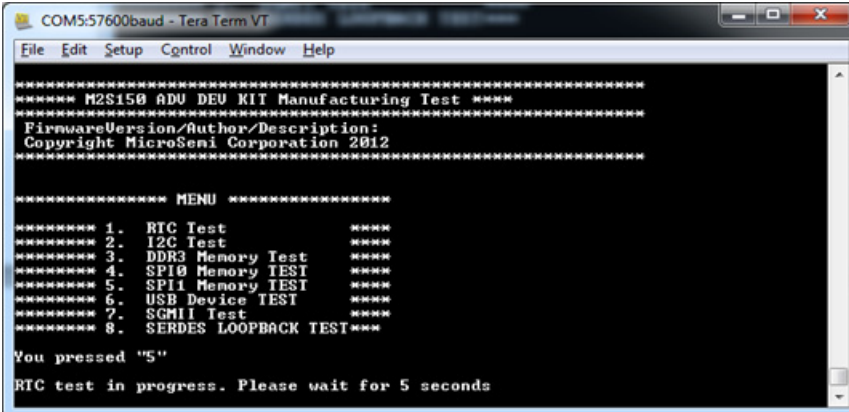

```

COM5:57600baud - Tera Term VT
File Edit Setup Control Window Help
***** M2S150 ADV DEV KIT Manufacturing Test ****
FirmwareVersion/Author/Description:
Copyright MicroSemi Corporation 2012
***** MENU *****
***** 1. RTC Test *****
***** 2. I2C Test *****
***** 3. DDR3 Memory Test *****
***** 4. SPI0 Memory TEST *****
***** 5. SPI1 Memory TEST *****
***** 6. USB Device TEST *****
***** 7. SGMII Test *****
***** 8. SERDES LOOPBACK TEST***
You pressed "5"
RTC test in progress. Please wait for 5 seconds

```

When the test is passed, the following message appears.

Figure 31 • RTC Test Passed

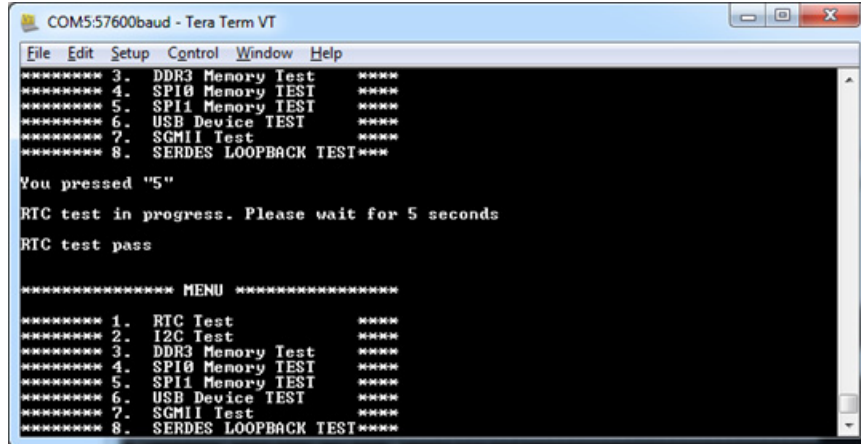

```

COM5:57600baud - Tera Term VT
File Edit Setup Control Window Help
***** 3. DDR3 Memory Test *****
***** 4. SPI0 Memory TEST *****
***** 5. SPI1 Memory TEST *****
***** 6. USB Device TEST *****
***** 7. SGMII Test *****
***** 8. SERDES LOOPBACK TEST*****

You pressed "5"
RTC test in progress. Please wait for 5 seconds
RTC test pass

***** MENU *****
***** 1. RTC Test *****
***** 2. I2C Test *****
***** 3. DDR3 Memory Test *****
***** 4. SPI0 Memory TEST *****
***** 5. SPI1 Memory TEST *****
***** 6. USB Device TEST *****
***** 7. SGMII Test *****
***** 8. SERDES LOOPBACK TEST*****

```

- Press **2** to run the I2C loopback test. Wait for five seconds for the test to be run. When the test is passed, the following message appears.

Figure 32 • I2C Test Passed

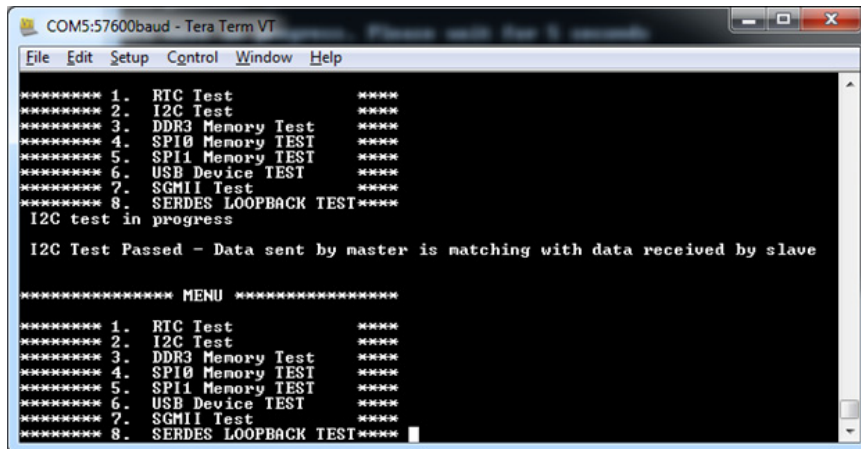

```

COM5:57600baud - Tera Term VT
File Edit Setup Control Window Help
***** 1. RTC Test *****
***** 2. I2C Test *****
***** 3. DDR3 Memory Test *****
***** 4. SPI0 Memory TEST *****
***** 5. SPI1 Memory TEST *****
***** 6. USB Device TEST *****
***** 7. SGMII Test *****
***** 8. SERDES LOOPBACK TEST*****

I2C test in progress

I2C Test Passed - Data sent by master is matching with data received by slave

***** MENU *****
***** 1. RTC Test *****
***** 2. I2C Test *****
***** 3. DDR3 Memory Test *****
***** 4. SPI0 Memory TEST *****
***** 5. SPI1 Memory TEST *****
***** 6. USB Device TEST *****
***** 7. SGMII Test *****
***** 8. SERDES LOOPBACK TEST*****

```

- Press **3** to run the DDR3 memory test. Wait for 30 seconds for the test to be run. When the test is passed, the following message appears.

Figure 33 • DDR3 Memory Test Passed

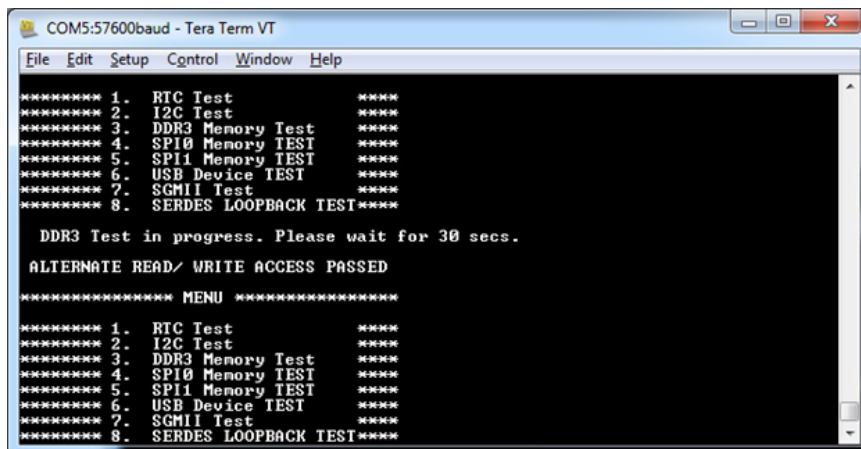

```

COM5:57600baud - Tera Term VT
File Edit Setup Control Window Help
***** 1. RTC Test *****
***** 2. I2C Test *****
***** 3. DDR3 Memory Test *****
***** 4. SPI0 Memory TEST *****
***** 5. SPI1 Memory TEST *****
***** 6. USB Device TEST *****
***** 7. SGMII Test *****
***** 8. SERDES LOOPBACK TEST*****

DDR3 Test in progress. Please wait for 30 secs.
ALTERNATE READ/ WRITE ACCESS PASSED

***** MENU *****
***** 1. RTC Test *****
***** 2. I2C Test *****
***** 3. DDR3 Memory Test *****
***** 4. SPI0 Memory TEST *****
***** 5. SPI1 Memory TEST *****
***** 6. USB Device TEST *****
***** 7. SGMII Test *****
***** 8. SERDES LOOPBACK TEST*****

```

- Press 4 to run the SPI0 memory test.
When the test is passed, the following message appears.

Figure 34 • SPI0 Memory Test Passed

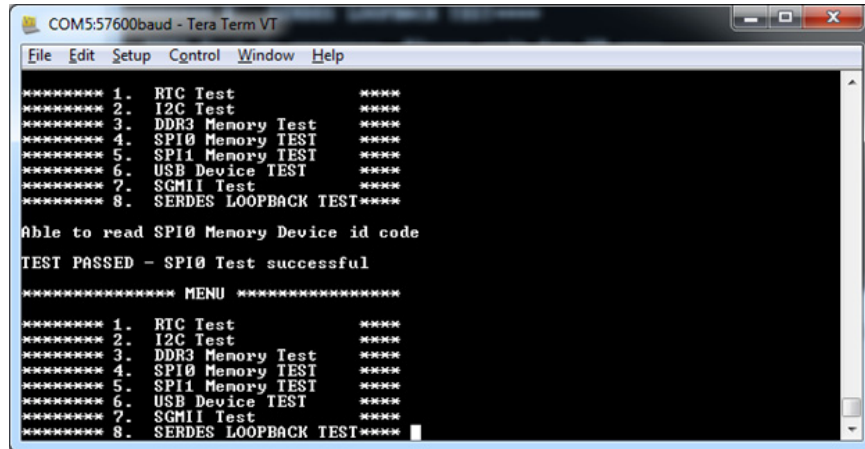

```

COM5:57600baud - Tera Term VT
File Edit Setup Control Window Help
***** 1. RTC Test          ****
***** 2. I2C Test         ****
***** 3. DDR3 Memory Test ****
***** 4. SPI0 Memory TEST ****
***** 5. SPI1 Memory TEST ****
***** 6. USB Device TEST  ****
***** 7. SGMII Test       ****
***** 8. SERDES LOOPBACK TEST****

Able to read SPI0 Memory Device id code
TEST PASSED - SPI0 Test successful

***** MENU *****
***** 1. RTC Test          ****
***** 2. I2C Test         ****
***** 3. DDR3 Memory Test ****
***** 4. SPI0 Memory TEST ****
***** 5. SPI1 Memory TEST ****
***** 6. USB Device TEST  ****
***** 7. SGMII Test       ****
***** 8. SERDES LOOPBACK TEST****

```

- Press 5 to run the SPI1 memory test.
When the test is passed, the following message is appears.

Figure 35 • SPI1 Memory Test Passed

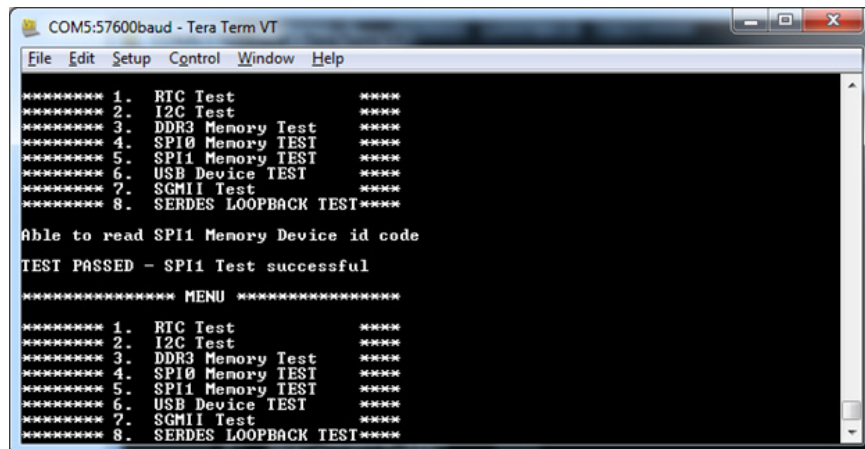

```

COM5:57600baud - Tera Term VT
File Edit Setup Control Window Help
***** 1. RTC Test          ****
***** 2. I2C Test         ****
***** 3. DDR3 Memory Test ****
***** 4. SPI0 Memory TEST ****
***** 5. SPI1 Memory TEST ****
***** 6. USB Device TEST  ****
***** 7. SGMII Test       ****
***** 8. SERDES LOOPBACK TEST****

Able to read SPI1 Memory Device id code
TEST PASSED - SPI1 Test successful

***** MENU *****
***** 1. RTC Test          ****
***** 2. I2C Test         ****
***** 3. DDR3 Memory Test ****
***** 4. SPI0 Memory TEST ****
***** 5. SPI1 Memory TEST ****
***** 6. USB Device TEST  ****
***** 7. SGMII Test       ****
***** 8. SERDES LOOPBACK TEST****

```

- Press 6 to run the USB device test.
When the test begins, the following message appears.

Figure 36 • USB Device Test Passed

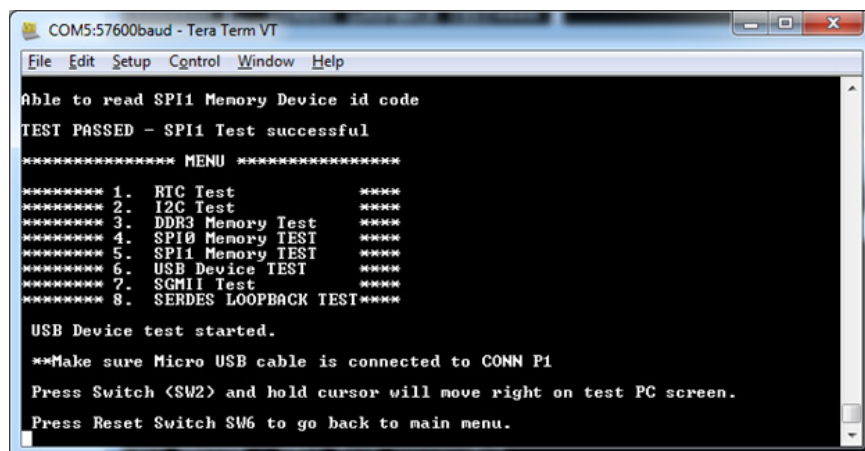

```

COM5:57600baud - Tera Term VT
File Edit Setup Control Window Help

Able to read SPI1 Memory Device id code
TEST PASSED - SPI1 Test successful

***** MENU *****
***** 1. RTC Test          ****
***** 2. I2C Test         ****
***** 3. DDR3 Memory Test ****
***** 4. SPI0 Memory TEST ****
***** 5. SPI1 Memory TEST ****
***** 6. USB Device TEST  ****
***** 7. SGMII Test       ****
***** 8. SERDES LOOPBACK TEST****

USB Device test started.

**Make sure Micro USB cable is connected to CONN P1
Press Switch <SW2> and hold cursor will move right on test PC screen.
Press Reset Switch SW6 to go back to main menu.

```

8. Press and hold the **SW2** switch on the board, and observe the mouse cursor moving to the right side.
9. Press **SW6** reset switch go back to the main menu.
10. Press **7** to run the SGMII test.
When the test begins, the DS1 LED is OFF. The DS10 LED starts glowing, and the DS8 LED starts blinking. The following message appears.

Figure 37 • SGMII Test

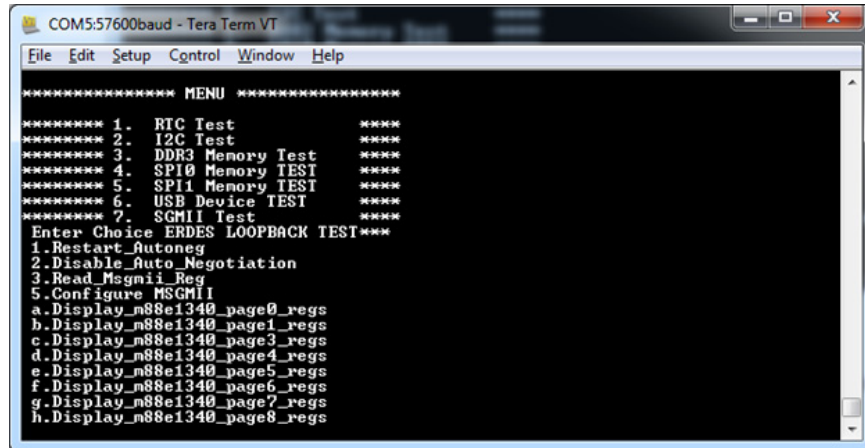

```

COM5:57600baud - Tera Term VT
File Edit Setup Control Window Help
***** MENU *****
***** 1. RTC Test *****
***** 2. I2C Test *****
***** 3. DDR3 Memory Test *****
***** 4. SPI0 Memory TEST *****
***** 5. SPI1 Memory TEST *****
***** 6. USB Device TEST *****
***** 7. SGMII Test *****
Enter Choice ERDES LOOPBACK TEST***
1.Restart_Autoneg
2.Disable_Auto_Negotiation
3.Read_Msgmii_Reg
5.Configure MSGMII
a.Display_n88e1340_page0_regs
b.Display_n88e1340_page1_regs
c.Display_n88e1340_page3_regs
d.Display_n88e1340_page4_regs
e.Display_n88e1340_page5_regs
f.Display_n88e1340_page6_regs
g.Display_n88e1340_page7_regs
h.Display_n88e1340_page8_regs

```

Note: If this message is not displayed, or if DS10 and DS8 LEDs do not blink, switch ON and OFF the **SW7** power supply switch on the board, and run the DDR3 test by pressing 3.

11. Press **7** to repeat the SGMII test.
A confirmation message is displayed,
12. Press **n** twice.
When the test is passed, the IP address of the host PC is displayed, as shown in the following figure.

Figure 38 • SGMII Test Passed

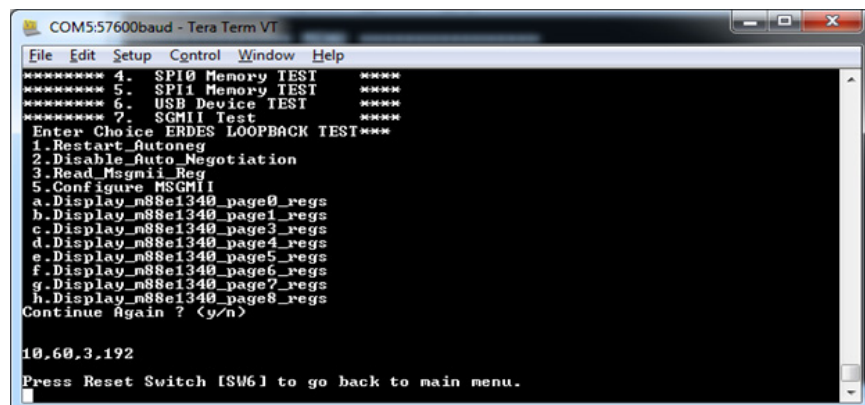

```

COM5:57600baud - Tera Term VT
File Edit Setup Control Window Help
***** 4. SPI0 Memory TEST *****
***** 5. SPI1 Memory TEST *****
***** 6. USB Device TEST *****
***** 7. SGMII Test *****
Enter Choice ERDES LOOPBACK TEST***
1.Restart_Autoneg
2.Disable_Auto_Negotiation
3.Read_Msgmii_Reg
5.Configure MSGMII
a.Display_n88e1340_page0_regs
b.Display_n88e1340_page1_regs
c.Display_n88e1340_page3_regs
d.Display_n88e1340_page4_regs
e.Display_n88e1340_page5_regs
f.Display_n88e1340_page6_regs
g.Display_n88e1340_page7_regs
h.Display_n88e1340_page8_regs
Continue Again ? <y/n>

10.60.3.192
Press Reset Switch [SW6] to go back to main menu.

```

Note: IP address may vary from one PC to the other PC.

13. Press the **SW6** reset switch on the board to go back to the main menu.

14. If the IP address is not displayed, perform the following steps to get the IP address.
 - i. Press 7 to run the SGMII test.

Figure 39 • SGMII Debug Test

```

Enter Choice
1.Restart_Autoneg
2.Disable_Auto_Negotiation
3.Read_Msgmii_Reg
5.Configure_MSGMII
a.Display_m88e1340_page0_regs
b.Display_m88e1340_page1_regs
c.Display_m88e1340_page3_regs
d.Display_m88e1340_page4_regs
e.Display_m88e1340_page5_regs
f.Display_m88e1340_page6_regs
g.Display_m88e1340_page7_regs
h.Display_m88e1340_page8_regs

```

- ii. Press 1 to restart auto-negotiation, and press y to continue.

Figure 40 • SGMII Debug Test

```

Continue Again ? (y/n)
y

Enter Choice
1.Restart_Autoneg
2.Disable_Auto_Negotiation
3.Read_Msgmii_Reg
5.Configure_MSGMII
a.Display_m88e1340_page0_regs
b.Display_m88e1340_page1_regs
c.Display_m88e1340_page3_regs
d.Display_m88e1340_page4_regs
e.Display_m88e1340_page5_regs
f.Display_m88e1340_page6_regs
g.Display_m88e1340_page7_regs
h.Display_m88e1340_page8_regs

```

- iii. Press 2 to disable auto-negotiation, and press y to continue.

Figure 41 • SGMII Debug Test

```

Continue Again ? (y/n)
y

Enter Choice
1.Restart_Autoneg
2.Disable_Auto_Negotiation
3.Read_Msgmii_Reg
5.Configure_MSGMII
a.Display_m88e1340_page0_regs
b.Display_m88e1340_page1_regs
c.Display_m88e1340_page3_regs
d.Display_m88e1340_page4_regs
e.Display_m88e1340_page5_regs
f.Display_m88e1340_page6_regs
g.Display_m88e1340_page7_regs
h.Display_m88e1340_page8_regs

```

iv. Press **n** twice to not repeat the action and to get the IP address, as shown in the following figure.

Figure 42 • SGMII Debug Test Passed

```

Enter Choice
1.Restart_Autoneg
2.Disable_Auto_Negotiation
3.Read_Msgmii_Reg
5.Configure MSGMII
a.Display_m88e1340_page0_regs
b.Display_m88e1340_page1_regs
c.Display_m88e1340_page3_regs
d.Display_m88e1340_page4_regs
e.Display_m88e1340_page5_regs
f.Display_m88e1340_page6_regs
g.Display_m88e1340_page7_regs
h.Display_m88e1340_page8_regs
Continue Again ? (y/n)

10.60.3.192

Press Reset Switch [SW6] to go back to main menu.
    
```

15. Press **SW6** to go back to the main menu.

16. Press **8** to run the SerDes loopback test.

Note: Ensure that the loopback cable is connected. (See [Setting Up Jumpers](#), page 50.)

Figure 43 • SerDes Loopback Test

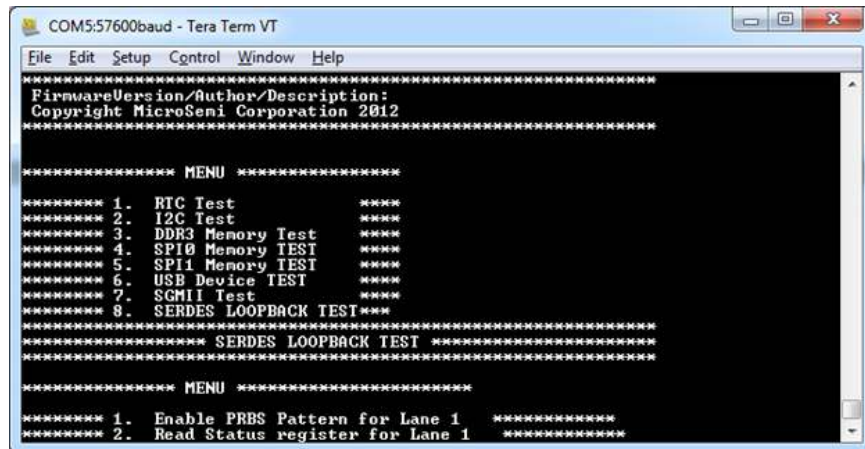

```

COM5:57600baud - Tera Term VT
File Edit Setup Control Window Help
*****
FirmwareVersion/Author/Description:
Copyright MicroSemi Corporation 2012
*****
***** MENU *****
***** 1. RTC Test *****
***** 2. I2C Test *****
***** 3. DDR3 Memory Test *****
***** 4. SPI0 Memory TEST *****
***** 5. SPI1 Memory TEST *****
***** 6. USB Device TEST *****
***** 7. SGMII Test *****
***** 8. SERDES LOOPBACK TEST*****
***** SERDES LOOPBACK TEST *****
***** MENU *****
***** 1. Enable PRBS Pattern for Lane 1 *****
***** 2. Read Status register for Lane 1 *****
    
```

17. Press **1** to enable PRBS pattern for Lane 1.

Figure 44 • SerDes Loopback Test - Enabling PRBS Pattern for Lane 1

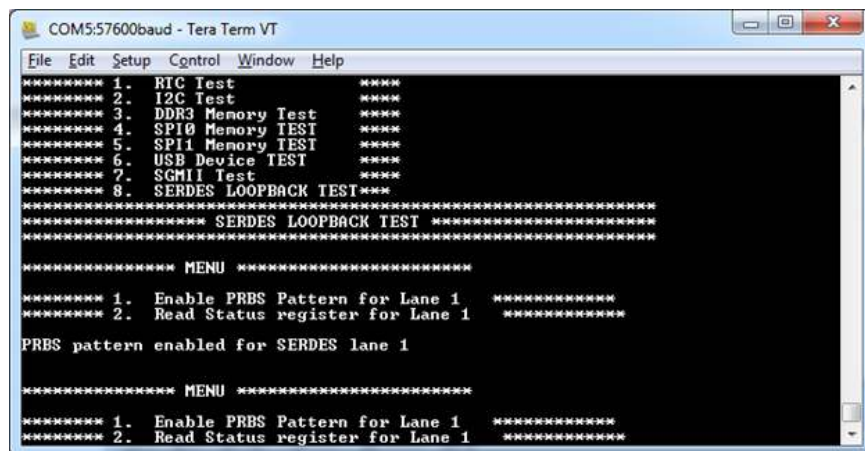

```

COM5:57600baud - Tera Term VT
File Edit Setup Control Window Help
*****
1. RTC Test *****
2. I2C Test *****
3. DDR3 Memory Test *****
4. SPI0 Memory TEST *****
5. SPI1 Memory TEST *****
6. USB Device TEST *****
7. SGMII Test *****
8. SERDES LOOPBACK TEST*****
***** SERDES LOOPBACK TEST *****
***** MENU *****
***** 1. Enable PRBS Pattern for Lane 1 *****
***** 2. Read Status register for Lane 1 *****
PRBS pattern enabled for SERDES lane 1
***** MENU *****
***** 1. Enable PRBS Pattern for Lane 1 *****
***** 2. Read Status register for Lane 1 *****
    
```

18. Press **2** to read the status register for Lane 1.
When the test is passed, the following message appears.

Figure 45 • SerDes Loopback Passed

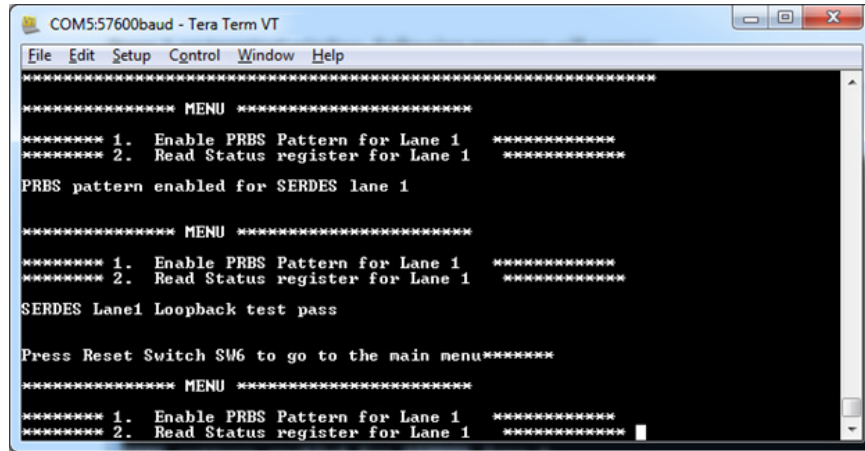

19. Press the **SW6** reset switch to go back to the main menu.