



FEATURES:

- Wide 4:1 Input Voltage Range
- High efficiency up to 88%
- 1500 VDC Isolation
- Over Current Protection
- No load consumption $\leq 0.12W$
- Operating Temperature $-40^{\circ}C$ to $+85^{\circ}C$
- Output Over Voltage protection
- Continuous Short Circuit Protection
- Input Under Voltage Protection
- Remote On/Off control



Models
Single output

Model	Input Voltage (V)	Output Voltage (V)	Output Current max (A)	Isolation (VDC)	Max Capacitive Load (uF)	Efficiency (%)
AM10CW-2403S-NZ	9-36	3.3	2.4	1500	2200	78
AM10CW-2405S-NZ	9-36	5	2	1500	2200	83
AM10CW-2409S-NZ	9-36	9	1.11	1500	680	85
AM10CW-2412S-NZ	9-36	12	0.83	1500	470	86
AM10CW-2415S-NZ	9-36	15	0.66	1500	330	86
AM10CW-2424S-NZ	9-36	24	0.41	1500	100	88
AM10CW-4803S-NZ*	18-75	3.3	2.4	1500	2200	79
AM10CW-4805S-NZ*	18-75	5	2	1500	2200	83
AM10CW-4812S-NZ*	18-75	12	0.83	1500	470	87
AM10CW-4815S-NZ*	18-75	15	0.66	1500	330	87
AM10CW-4824S-NZ*	18-75	24	0.41	1500	100	88

*Need an input capacitor in order to meet CISPR32 / EN55032 Class A.

Models
Dual output

Model	Input Voltage (V)	Output Voltage (V)	Output Current max (A)	Isolation (VDC)	Max Capacitive Load (uF)	Efficiency (%)
AM10CW-2405D-NZ*	9-36	± 5	± 1	1500	± 1000	83
AM10CW-2409D-NZ	9-36	± 9	± 0.55	1500	± 680	86
AM10CW-2412D-NZ*	9-36	± 12	± 0.41	1500	± 470	87
AM10CW-2415D-NZ	9-36	± 15	± 0.33	1500	± 330	87
AM10CW-2424D-NZ*	9-36	± 24	± 0.2	1500	± 100	87
AM10CW-4805D-NZ*	18-75	± 5	± 1	1500	± 1000	83
AM10CW-4812D-NZ*	18-75	± 12	± 0.41	1500	± 470	87
AM10CW-4815D-NZ*	18-75	± 15	± 0.33	1500	± 330	87
AM10CW-4824D-NZ*	18-75	± 24	± 0.2	1500	± 100	87

Add suffix “-ST” for optional screw terminal bottom plate or “-STD” for optional DIN Rail screw terminal bottom plate and input reverse polarity protection.

Due to the input reverse polarity protection, models with “-ST” and “-STD” option will have their minimum input and start-up voltage increased by 1VDC and efficiency decreased by 2%.

*Need an input capacitor in order to meet CISPR32 / EN55032 Class A.

NOTE: All specifications in this datasheet are measured at an ambient temperature of 25°C, humidity<75%, nominal input voltage and at rated output load unless otherwise specified.

Input Specifications

Parameters	Nominal	Typical	Maximum	Units
Voltage range	24 Vin 48 Vin	9-36 18-75		VDC
Filter		Pi		
Absolute Maximum Rating (1sec)	24 Vin 48 Vin		-0.7 - 50 -0.7 - 100	VDC
No Load Input Current	24 Vin 48 Vin	5 4	12 8	mA
Input reflected current	24 Vin	40		mA

	48 Vin	30		
Input Under voltage turn off	24 Vin 48 Vin	6.5 15.5		VDC
Startup time	Nominal input, resistive load	10		ms
Remote On/Off Control	On Off	3.5-12VDC or leave open 0-1.2VDC or connect to GND, idle current 6-10mA		

Isolation Specifications

Parameters	Conditions	Typical	Maximum	Units
Tested I/O voltage	60 sec, <1mA	1500		VDC
Resistance	500VDC	>1000		MOhm
Capacitance	I/O, 100KHz/0.1V	1000		pF

Output Specifications

Parameters	Conditions	Typical	Maximum	Units
Voltage accuracy*	0% to 100% load	±1	±3	%
Voltage balance (Dual Output Models)	Balanced Load		±1.5	%
Over voltage protection		110-160		% of Vout
Over current protection		110-190		% of Iout
Short Circuit protection		Continuous		
Short circuit restart		Auto-Recovery		
Line voltage regulation (Single)	Full load, LL to HL	±0.2	±0.5	% of Vin
Line voltage regulation (Dual)	Full load, LL to HL	±0.5	±1	% of Vin
Load voltage regulation (Single)**	5% to 100% load	±0.5	±1	%
Load voltage regulation (Dual)**	5% to 100% load	±0.5	±1.5	%
Cross Regulation (Dual Output Models)	50% load on one output & 10-100% load on second load		±5	%
Temperature coefficient	100% load		±0.03	%/°C
Ripple & Noise***	20MHz Bandwidth, 5-100% load	40	80	mV p-p
Transient recovery time	25% load step change	300	500	µs
Transient recovery deviation	25% load step change	±3	±5	%

* Voltage accuracy of ±5 and ±9VDC output models at 0% to 5% is ±5% max.

** Load voltage regulation at 0% to 100% is ±5%.

*** Ripple & Noise at 0% to 5% load is 5%Vout max.

General Specifications

Parameters	Conditions	Typical	Maximum	Units
Switching frequency*	100% load	350		KHz
Operating temperature	See derating curve	-40 to +85		°C
Storage temperature		-55 to +125		°C
Maximum case temperature			100	°C
Cooling		Free air convection		
Humidity			95	% RH
Case material		Aluminum Alloy		
Weight	PCB mountable models	12.5		g
	With optional -ST mounting plate	36.0		
	With optional -STD mounting plate	56.0		
Dimensions (L x W x H)	PCB mountable models	1.00 x 1.00 x 0.46 inch (25.40 x 25.40 x 11.70 mm)		
	With optional -ST mounting plate	2.99 x 1.24 x 0.84 inch (76.00 x 31.50 x 21.20 mm)		
	With optional -STD mounting plate	2.99 x 1.24 x 1.02 inch (76.00 x 31.50 x 25.80 mm)		
MTBF		>1,000,000 hours (MIL-HDBK -217F, Ground Benign, t _a +25°C)		
Maximum soldering temperature	1.5mm from case for 10 sec		300	°C

* Switching frequency reduces at 0% to 50% load for better efficiency.

Environmental Specifications

Parameters		
Vibration	Test mode	10-150Hz
	Acceleration	5G, 90min along all axles

Safety Specifications

Parameters		
Approval	CE, UL	
Standards	IEC/EN/UL60950-1	
	EN 55032, class A	
	EN 55032, class B (with the recommended EMC circuit EMI part)	
	Electrostatic Discharge Immunity	IEC 61000-4-2, Contact $\pm 4\text{KV}$, Criteria B
	RF, Electromagnetic Field Immunity	IEC 61000-4-3, 10V/m, Criteria A
	Electrical Fast Transient / Burst Immunity	IEC 61000-4-4, $\pm 2\text{KV}$, Criteria B (with the recommended EMC circuit EMS part)
	Surge Immunity	IEC 61000-4-5, $\pm 2\text{KV}$, Criteria B (with the recommended EMC circuit EMS part)
	RF, Conducted Disturbance Immunity	IEC 61000-4-6, 3 Vrms, Criteria A
Voltage dips, Short Interruptions & Voltage variations Immunity	IEC 61000-4-29: 0-70%, Criteria B	

Derating

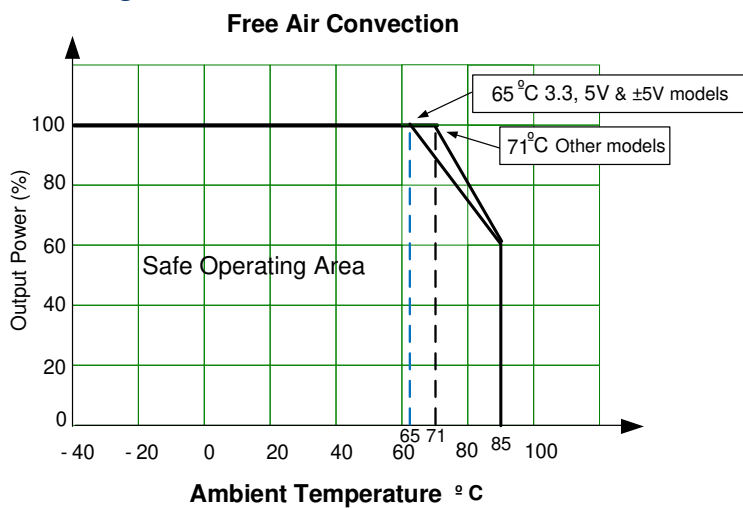

Dimensions

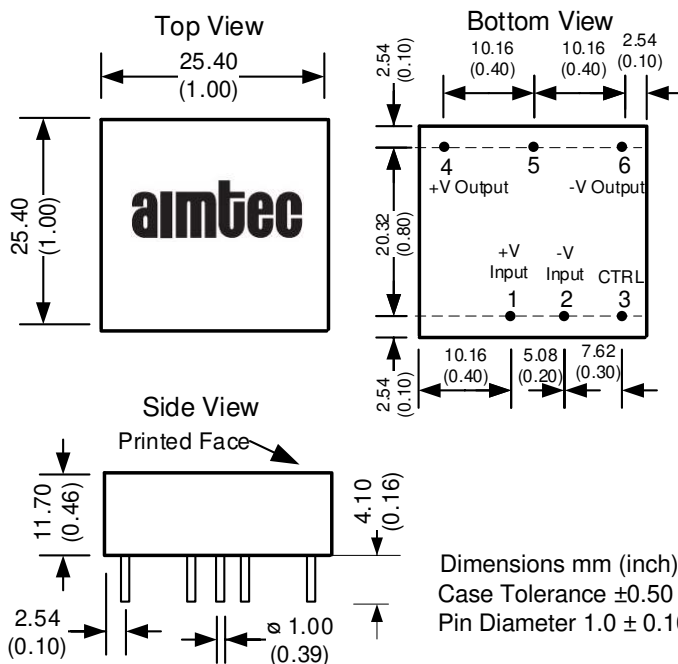

Pin Out Specifications

Pin	Single	Dual
1	+V Input	+V Input
2	-V Input	-V Input
3	On/Off Control	On/Off Control
4	+V Output	+V Output
5	No pin	Common
6	-V Output	-V Output

Dimensions with -ST options

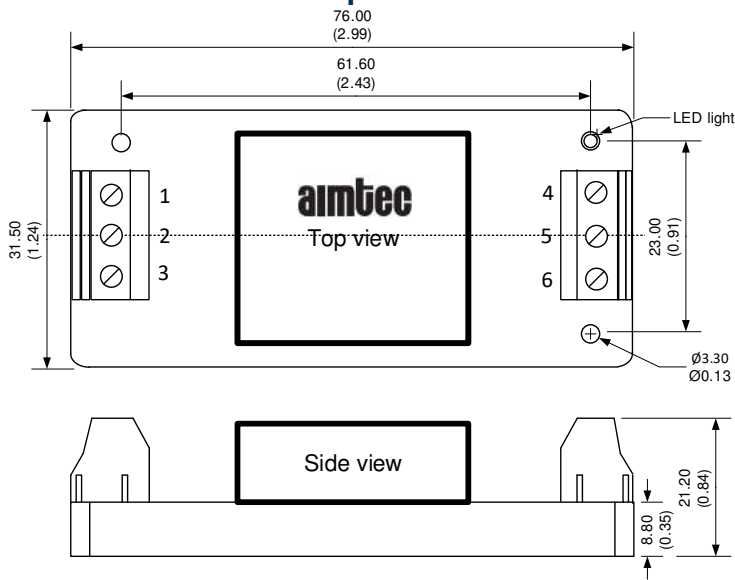

Pin Out Specifications

Pin	Single	Dual
1	On/Off Control	On/Off Control
2	-V Input	-V Input
3	+V Input	+V Input
4	-V Output	-V Output
5	No pin	Common
6	+V Output	+V Output

Dimensions: mm (inch)
Case Tolerance: ± 0.50 (0.02)
Wire gauge: 24-12AWG
Torque Tightening: Max 0.4N*m

Dimensions with -STD options

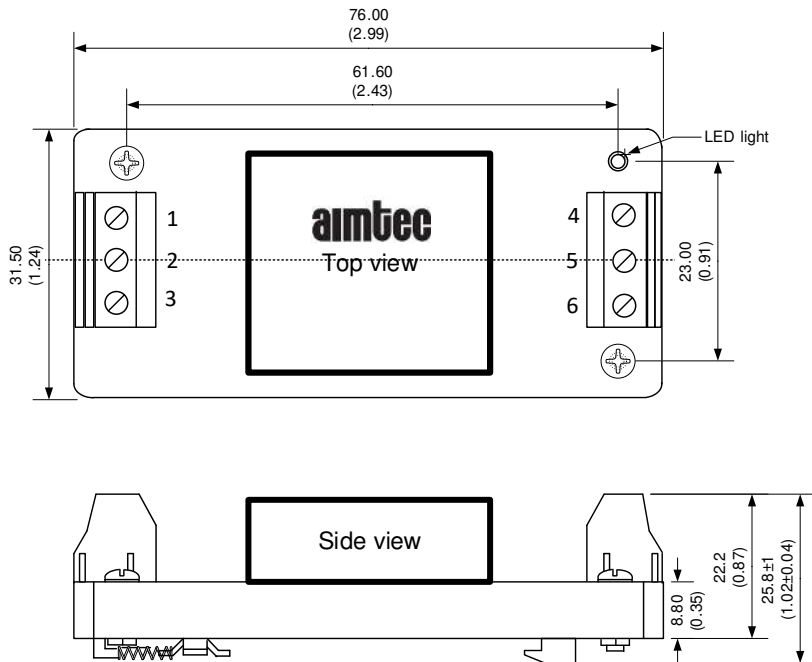

Pin Out Specifications

Pin	Single	Dual
1	On/Off Control	On/Off Control
2	-V Input	-V Input
3	+V Input	+V Input
4	-V Output	-V Output
5	No Connection	Common
6	+V Output	+V Output

Dimensions: mm (inch)
Case Tolerance: ± 0.50 (0.02)
Wire gauge: 24-12AWG
Mounting Rail: TS35
Torque Tightening: Max 0.4N*m

Typical application circuits

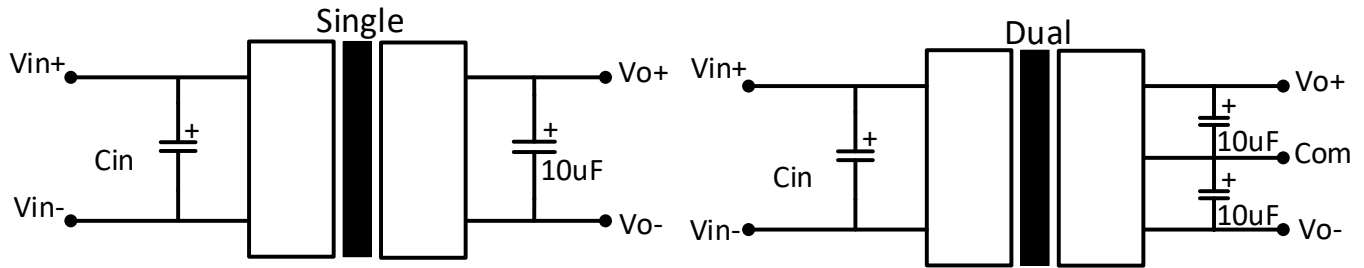

	24V input	48V input
Cin	100 μ F	10-47 μ F

Recommended EMC Circuits

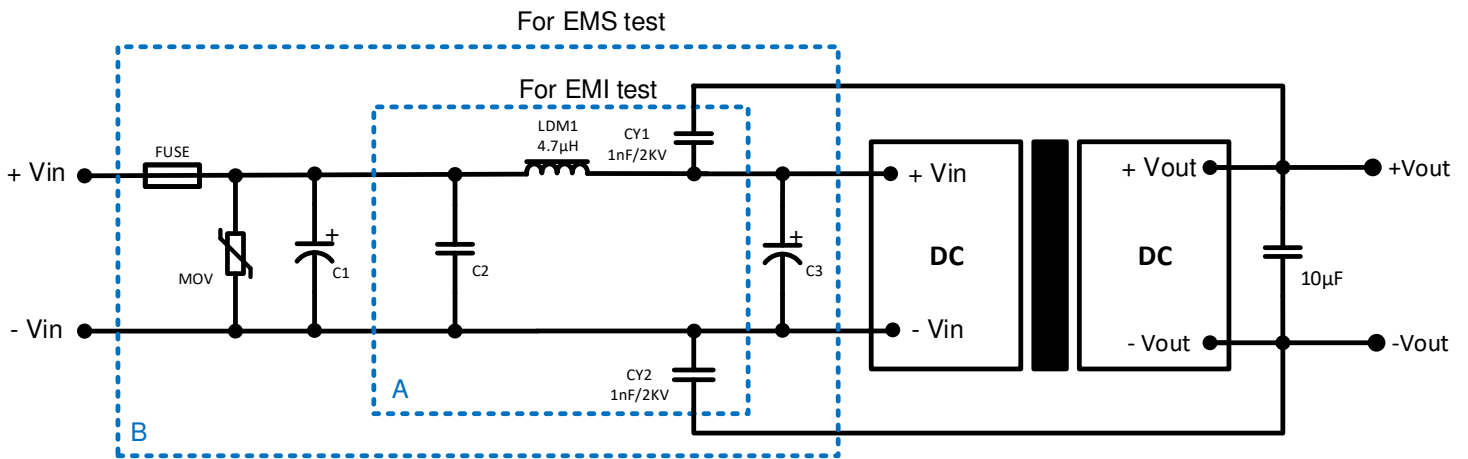

	24V input	48V input
MOV	S20K30	S14K60
C1/C3	330 μ F/50V	330 μ F/100V
C2	1 μ F/50V	1 μ F/100V

NOTE: 1. Datasheets are updated as needed and as such, specifications are subject to change without notice. Once printed or downloaded, datasheets are no longer controlled by Aimtec; refer to www.aimtec.com for the most current product specifications. 2. Product labels shown, including safety agency certifications on labels, may vary based on the date manufactured. 3. Mechanical drawings and specifications are for reference only. 4. All specifications are measured at an ambient temperature of 25°C, humidity<75%, nominal input voltage and at rated output load unless otherwise specified. 5. Aimtec may not have conducted destructive testing or chemical analysis on all internal components and chemicals at the time of publishing this document. CAS numbers and other limited information are considered proprietary and may not be available for release. 6. This product is not designed for use in critical life support systems, equipment used in hazardous environments, nuclear control systems or other such applications which necessitate specific safety and regulatory standards other the ones listed in this datasheet. 7. Warranty is in accordance with Aimtec's standard Terms of Sale available at www.aimtec.com.