

Board Level Heat Sinks

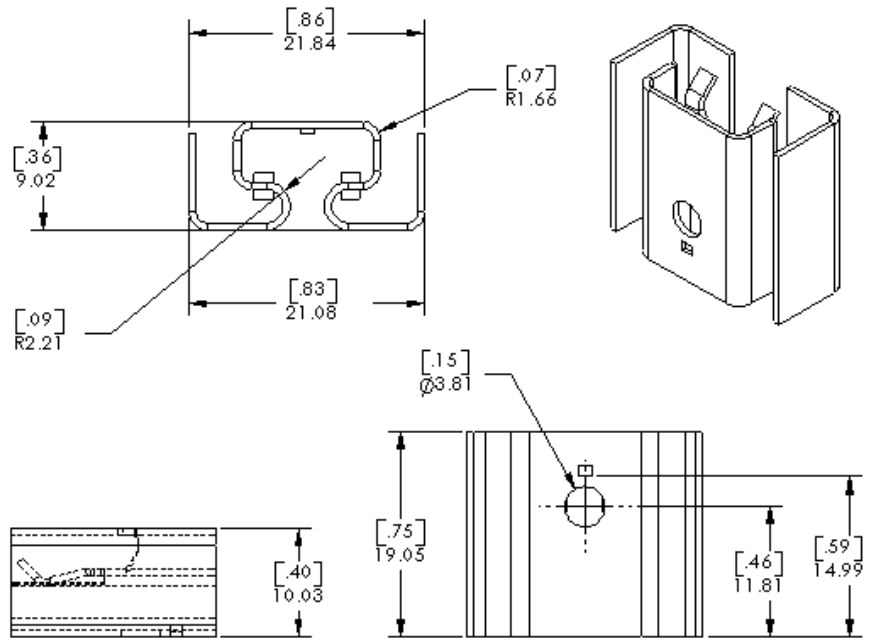

ThermaFlo

P/N: 833202B00000

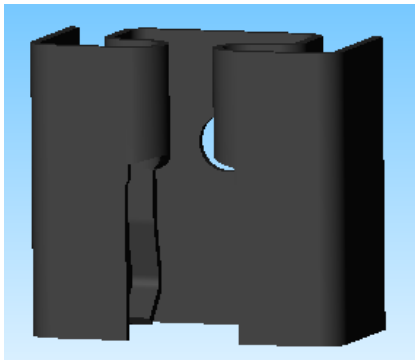

PRODUCT SPECIFICATIONS

- Devices: TO-220
- Size: 10.0 x 21.2 x 19.0 mm
- Material: Aluminum, 0.8 mm Thick
- Type: Stamped
- IC Mounting: Integrated Spring
- PCB Mounting: Device Leads
- Finish: Black Anodized
- Package: Bulk

FEATURES & BENEFITS

- No Hardware Device Attachment
- Constant Spring Force Tension
- RoHS Compliant



CUSTOMIZED HEATSINKS

- Specialized Plating
- Specialized Body Configurations
- Contact Applications Engineering

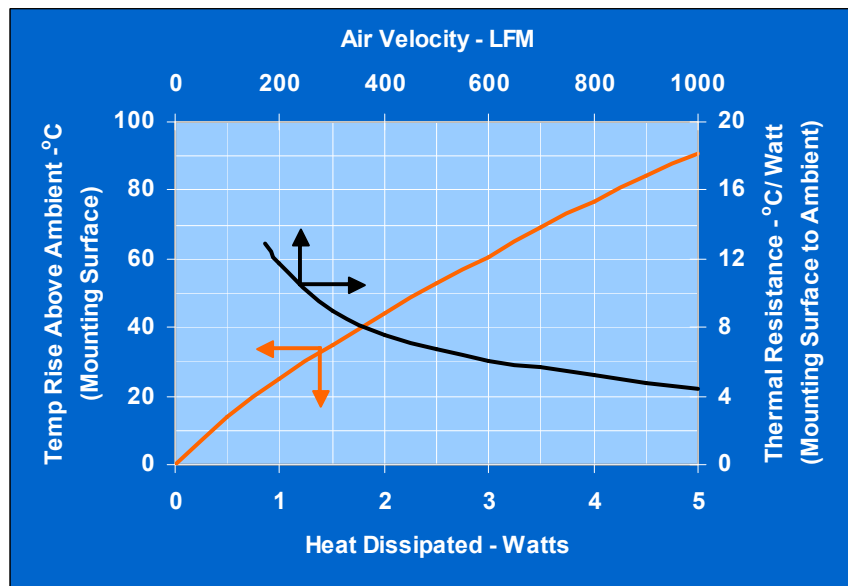

TO-220

COMAIR ROTRON, INC
 8929 Terman Court, San Diego, CA 92121
 Ph (858) 348-6200 Fax (858) 566-4577
 E-mail: sales@comairrotron.com,
 Web: www.comairrotron.com