

## 12 V, 7.8 W isolated flyback converter based on VIPer114LS

Data brief



### Features

- Universal input mains range: 90 – 265V<sub>AC</sub>, frequency: 50 – 60 Hz
- Output voltage: 12 V
- Output current: 0.65 A
- Very compact size
- Stand-by mains consumption: < 20 mW at 230V<sub>AC</sub>
- Average efficiency: > 81%
- EMI: according to EN55022-Class-B
- RoHS compliant

### Description

The STEVAL-ISA197V1 evaluation board implements a 7.8 W (12 V / 0.65 A) isolated flyback wide range mains developed for general purpose applications.

The core of the application is the innovative VIPer114LS IC, designed for smart power supplies incorporating green energy management.

The device is a high-voltage converter that intelligently integrates an 800 V rugged power MOSFET with PWM current-mode control. VIPer114LS operates at fixed frequency 60 kHz with frequency jittering to meet standards regarding electromagnetic disturbance. The multiple protections on the device, including pulse skip mode to avoid flux-runaway, delayed overload, max duty cycle counter, input or output overvoltage and thermal shutdown improve the reliability and safety of the design.

The main characteristics of the evaluation board are its small size and minimal BOM, high efficiency and low standby consumption. Extremely low consumption under the no-load condition is ensured thanks to burst mode operation, which reduces the average switching frequency and minimizes all frequency-related losses.

# 1 Schematic diagram

Figure 1: STEVAL-ISA197V1 circuit schematic

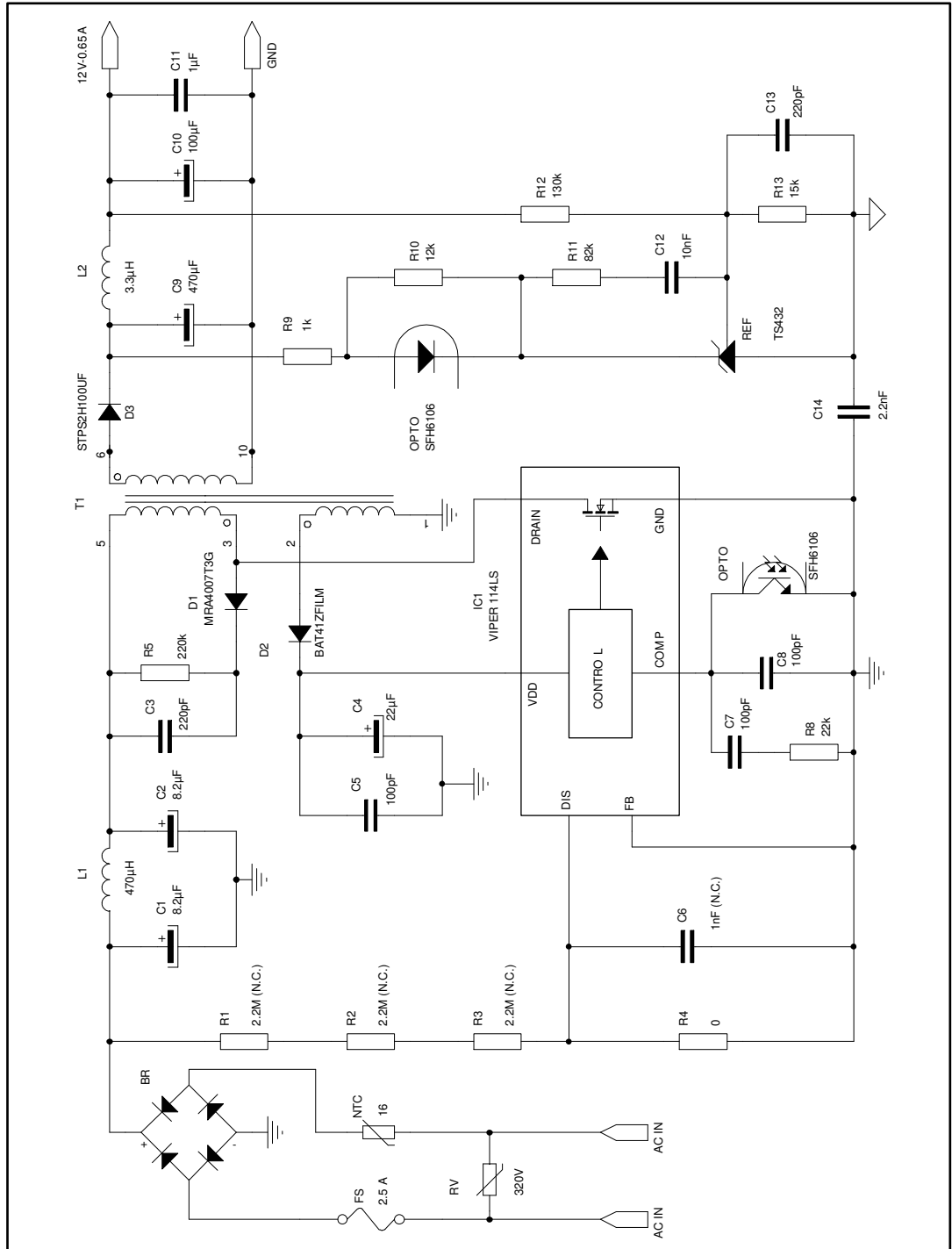

## 2 Revision history

Table 1: Document revision history

Date	Version	Changes
28-Jun-2017	1	Initial release.

**IMPORTANT NOTICE – PLEASE READ CAREFULLY**

STMicroelectronics NV and its subsidiaries ("ST") reserve the right to make changes, corrections, enhancements, modifications, and improvements to ST products and/or to this document at any time without notice. Purchasers should obtain the latest relevant information on ST products before placing orders. ST products are sold pursuant to ST's terms and conditions of sale in place at the time of order acknowledgement.

Purchasers are solely responsible for the choice, selection, and use of ST products and ST assumes no liability for application assistance or the design of Purchasers' products.

No license, express or implied, to any intellectual property right is granted by ST herein.

Resale of ST products with provisions different from the information set forth herein shall void any warranty granted by ST for such product.

ST and the ST logo are trademarks of ST. All other product or service names are the property of their respective owners.

Information in this document supersedes and replaces information previously supplied in any prior versions of this document.

© 2017 STMicroelectronics – All rights reserved